



2017-18 Formula SAE® Rules Table of Contents

PART A - ADMINISTRATIVE REGULATIONS	4
ARTICLE 1: FORMULA SAE OVERVIEW AND COMPETITION	4
ARTICLE 2: THE 2017-2018 FORMULA SAE SERIES	5
ARTICLE 3: FORMULA SAE RULES AND ORGANIZER AUTHORITY	6
ARTICLE 4: INDIVIDUAL PARTICIPATION REQUIREMENTS	8
ARTICLE 5: FACULTY ADVISOR, ELECTRICAL SYSTEM OFFICER AND ELECTRICAL SYSTEM ADVISOR	10
ARTICLE 6: VEHICLE ELIGIBILITY	11
ARTICLE 7: REGISTRATION	12
ARTICLE 8: VEHICLE DOCUMENTATION, DEADLINES AND PENALTIES	14
ARTICLE 9: PROTESTS	18
ARTICLE 10: QUESTIONS ABOUT THE FORMULA SAE RULES	18
APPENDIX A – SAE TECHNICAL STANDARDS	20
PART T - GENERAL TECHNICAL REQUIREMENTS	22
ARTICLE 1: VEHICLE REQUIREMENTS & RESTRICTIONS	22
ARTICLE 2: GENERAL DESIGN REQUIREMENTS	22
ARTICLE 3: DRIVER’S CELL	24
ARTICLE 4: COCKPIT	47
ARTICLE 5: DRIVERS EQUIPMENT (BELTS AND COCKPIT PADDING)	50
ARTICLE 6: GENERAL CHASSIS RULES	55
ARTICLE 7: BRAKE SYSTEM	58
ARTICLE 8: POWERTRAIN	59
ARTICLE 9: AERODYNAMIC DEVICES	61
ARTICLE 10: COMPRESSED GAS SYSTEMS AND HIGH PRESSURE HYDRAULICS	63
ARTICLE 11: FASTENERS	64
ARTICLE 12: TRANSPONDERS	65
ARTICLE 13: VEHICLE IDENTIFICATION	65
ARTICLE 14: EQUIPMENT REQUIREMENTS	66
ARTICLE 15: POSSIBLE FUTURE RULES CHANGES	70
APPENDIX T-1 STRUCTURAL EQUIVALENCY SPREADSHEET	71
APPENDIX T-2 IMPACT ATTENUATOR DATA REPORT	71
APPENDIX T-3 STANDARD IMPACT ATTENUATOR	72
APPENDIX T-4 FRONT BULKHEAD AND MAIN ROLL HOOP SUPPORT EXAMPLE CONFIGURATIONS	73
PART AF - ALTERNATIVE FRAME RULES	74
ARTICLE 1: GENERAL REQUIREMENTS	74
ARTICLE 2: STRUCTURAL REQUIREMENTS CERTIFICATION FORM (SRCF)	75
ARTICLE 3: DEFINITIONS	75
ARTICLE 4: STRUCTURAL REQUIREMENTS	75
ARTICLE 5: GENERAL ANALYSIS REQUIREMENTS	78
ARTICLE 6: INTRUSION PREVENTION	79
ARTICLE 7: NON-APPLICABLE RULES: CHASSIS/FRAME	80
ARTICLE 8: NON-APPLICABLE RULES: ACCUMULATOR CONTAINER	80
PART IC - INTERNAL COMBUSTION ENGINE VEHICLES	81
ARTICLE 1: INTERNAL COMBUSTION ENGINE POWERTRAINS	81
ARTICLE 2: FUEL AND FUEL SYSTEM	90
ARTICLE 3: EXHAUST SYSTEM AND NOISE CONTROL	94
ARTICLE 4: ELECTRICAL SYSTEM AND SHUTDOWN SYSTEM	95

PART EV - TECHNICAL REGULATIONS – ELECTRIC VEHICLES.....	97
ARTICLE 1: ELECTRIC SYSTEM DEFINITIONS	97
ARTICLE 2: ELECTRIC POWERTRAIN.....	98
ARTICLE 3: TRACTIVE SYSTEM - ENERGY STORAGE.....	101
ARTICLE 4: TRACTIVE SYSTEM – GENERAL REQUIREMENTS	106
ARTICLE 5: SHUTDOWN CIRCUIT AND SYSTEMS	113
ARTICLE 6: FUSING	118
ARTICLE 7: ELECTRICAL SYSTEM TESTS	119
ARTICLE 8: HIGH VOLTAGE PROCEDURES & TOOLS	120
ARTICLE 9: ELECTRICAL SYSTEM FORM AND FMEA.....	122
PART S - STATIC EVENT REGULATIONS	124
ARTICLE 1: STATIC EVENTS AND MAXIMUM SCORES	124
ARTICLE 2: TECHNICAL INSPECTION.....	124
ARTICLE 3: BUSINESS LOGIC CASE	126
ARTICLE 4: COST AND MANUFACTURING EVENT	127
ARTICLE 5: PRESENTATION EVENT.....	138
ARTICLE 6: DESIGN EVENT	140
APPENDIX S – 1 COST MODEL AND COST METHODOLOGY	144
APPENDIX S – 2 STANDARD PART NUMBERING	149
APPENDIX S – 3 ORGANIZED LIST OF SYSTEMS & ASSEMBLIES	150
APPENDIX S – 4 POWER TOOL PACKAGE ENVELOPES.....	150
APPENDIX S – 5 FSAE COST EVENT ADDENDUM.....	151
APPENDIX S – 6 PRESENTATION JUDGING	152
APPENDIX S – 7 DESIGN JUDGING	152
PART D - DYNAMIC EVENT REGULATIONS.....	153
ARTICLE 1: DYNAMIC EVENTS AND MAXIMUM SCORES	153
ARTICLE 2: WEATHER CONDITIONS.....	153
ARTICLE 3: RUNNING IN RAIN	153
ARTICLE 4: DRIVER LIMITATIONS	155
ARTICLE 5: ACCELERATION EVENT	156
ARTICLE 6: SKID-PAD EVENT	157
ARTICLE 7: AUTOCROSS EVENT.....	159
ARTICLE 8: ENDURANCE AND EFFICIENCY	162
ARTICLE 9: FLAGS.....	170
ARTICLE 10: RULES OF CONDUCT.....	171
ARTICLE 11: GENERAL RULES	172
ARTICLE 12: PIT RULES	173
ARTICLE 13: DRIVING RULES	174
ARTICLE 14: DEFINITIONS.....	175

2017-18 Formula SAE Rules INTRODUCTION

The Formula SAE are on a two year rules cycle. Major changes will be made to the regulations only in odd numbered years. This publication of 2017 Formula SAE Rules will govern 2017-2018 competition years, however, if the organizers and FSAE Rules Committee find a need to make a change in even years they have the authority to do so. Regardless of this policy, please note that rule changes for EV may take place yearly.

Please note that the summary of changed rules and the changed portions marked within the rules themselves are provided for courtesy only, and may not include all changes. Teams and other participants in the Formula SAE competition are responsible for reading and complying with the rules in their entirety. Please review the applicable rules and do not assume that items from previous years remain valid.

Definitions of Terms Used in the Rules

- “Must” designates a requirement.
- “Should” gives a recommendation
- “May” gives permission, neither a requirement or a recommendation

Notable Changes for 2017-2018

These selected changes are provided to highlight key items that may affect the design or tech inspection.

- A1.4 Dynamic Event Points
- T3.0 and subsections – Structural
- T3.20, T3.21 Impact Attenuator
- T4.1 Cockpit Opening Template
- T4.2 Cockpit Internal Template
- T5.0 and subsections, T14.2 – Driver Safety Equipment
- T9.2 Front Aerodynamic
- T11.1 Fasteners
- IC1.1 Engine
- IC1.11 through IC1.18 Electronic Throttle Control
- IC2.6 Fuel Filler Neck
- IC3.2.3, IC3.3 Sound Level
- IC4.4.4, IC 4.6 Batteries and Voltage Limits
- EV2.3, 2.4, 2.5, 3.4, 5.8 Electric Vehicle
- S6.0 Design Event

Additional revisions as of August 31st.

T3.40.4 – last sentence of (d) was deleted due to being outdated.

T5.4.1 & T5.4.2 – correction was made due to shoulder harness bar rule proposal not included in June revision and old rule also having been deleted leaving the rules with no strength requirement.

Also Table in Rule T3.4.1 has been updated

AF7.11 through AF7.17 – just correcting the Part T cross references.

EV4.11.6 – new rules missed in June revision

EV6.1 – revisions to existing rules missed in June revision

EV4.12.1 through EV4.12.4 – revisions to existing rules missed in June revision

D6.8.1 and 6.8.3 – clarifications made to current rule

2017-18 Formula SAE Rules

PART A - ADMINISTRATIVE REGULATIONS

ARTICLE 1: FORMULA SAE OVERVIEW AND COMPETITION

A1.1 Formula SAE Competition Objective

The Formula SAE® Series competitions challenge teams of university undergraduate and graduate students to conceive, design, fabricate, develop and compete with small, formula style, vehicles.

A1.1.1 To give teams the maximum design flexibility and the freedom to express their creativity and imaginations there are very few restrictions on the overall vehicle design. The challenge to teams is to develop a vehicle that can successfully compete in all the events described in the FSAE Rules. The competitions themselves give teams the chance to demonstrate and prove both their creativity and their engineering skills in comparison to teams from other universities around the world.

A1.2 Vehicle Design Objectives

For the purpose of the Formula SAE competition, teams are to assume that they work for a design firm that is designing, fabricating, testing and demonstrating a prototype vehicle for the non-professional, weekend, competition market.

A1.2.1 The vehicle should have very high performance in terms of acceleration, braking and handling and be sufficiently durable to successfully complete all the events described in the Formula SAE Rules and held at the Formula SAE competitions.

A1.2.2 The vehicle must accommodate drivers whose stature ranges from 5th percentile female to 95th percentile male and must satisfy the requirements of the Formula SAE Rules.

Driver accommodation includes but is not limited to: driver visibility, steering wheel and shifter locations, pedals, lap and shoulder belt angles and head rest position. Detailed anthropometric data for the 5th percentile female and 95th percentile male may be found on the FSAE website <http://fsaeonline.com/>.

A1.2.3 Additional design factors to be considered include: aesthetics, cost, ergonomics, maintainability, manufacturability, and reliability.

A1.2.4 Once the vehicle has been completed and tested, your design firm will attempt to “sell” the design to a “corporation” that is considering the production of a competition vehicle. The challenge to the design team is to develop a prototype car that best meets the FSAE vehicle design goals and which can be profitably marketed.

A1.2.5 Each design will be judged and evaluated against other competing designs to determine the best overall car.

A1.3 Good Engineering Practices

Vehicles entered into Formula SAE competitions are expected to be designed and fabricated in accordance with good engineering practices.

A1.4 Judging Categories

The cars are judged in a series of static and dynamic events including: technical inspection, cost, presentation, and engineering design, solo performance trials, and high performance track endurance.

A1.4.1 The dynamic events are scored to determine how well the car performs. Each dynamic event has specified minimum acceptable performance levels that are reflected in the scoring equations.

The following points are possible:

Static Events:

Presentation	75
Engineering Design	150 (may be changed to 200 for 2018)
Cost Analysis	100

Dynamic Events

Acceleration	100
Skid-Pad	75
Autocross	125
Efficiency	100
<u>Endurance</u>	<u>275</u> (may be changed to 225 for 2018)

Total Points 1,000

ARTICLE 2: THE 2017-2018 FORMULA SAE SERIES

A2.1 The 2017-2018 Formula SAE Competition Series consists of the following ten (10) competitions:

Formula SAE Michigan held in Michigan, USA and organized by SAE International
 Formula SAE Lincoln held in Nebraska, USA and organized by SAE International
 Formula SAE Electric held in Nebraska, USA and organized by SAE International
 Formula SAE Australasia held in Australia and organized by SAE Australasia
 Formula SAE Brazil held in Brazil and organized by SAE Brazil
 Formula SAE Italy held in Italy and organized by ATA
 Formula Student held in the United Kingdom and organized by IMechE
 Formula Student Austria held in Austria and organized by Formula Student Austria
 Formula Student Germany held in Germany and organized by FSG e.V.
 Student Formula Japan held in Japan and organized by JSAE

A2.2 Open Registration

All Formula SAE competitions have open registration policies and accept registrations by student teams representing universities in any country.

A2.3 Rule Variations

All competitions in the Formula SAE Series may post some minor rule variations specific to the operation of the events in their countries. However, the vehicle design requirements and restrictions will remain unchanged. Any rule variations will be posted on the websites specific to those competitions.

A2.4 Official Announcements and Competition Information

Teams are required to read the published announcements by SAE and the other organizing bodies and to be familiar with all official announcements concerning the competitions and rules interpretations released by the FSAE Rules Committee.

A2.4.1 Formula SAE News - North American Formula SAE Competitions

Formula SAE News will be provided to students in all three forms of media:

- Emails to registered student members online www.sae.org
- Press releases published online at <http://students.sae.org/competitions/formulaseries/>
- Rules updates published online at <http://fsaeonline.com/>

A2.5 Official Languages

The official language of the Formula SAE series is English. Document submissions, presentations and discussions in English are acceptable at all competitions in the series.

A2.5.1 Team members, judges, and officials at FSAE Brazil, FSAE Italy and SF Japan may use their respective national languages for document submissions, presentations and discussions if all the parties involved agree to the use of that language.

A2.5.2 The languages in use at the competitions of Formula SAE series are:

Formula SAE Michigan - English
Formula SAE Lincoln – English
Formula SAE Electric – English
Formula SAE Australasia - English
Formula SAE Brazil - Portuguese and English
Formula SAE Italy - Italian and English
Formula Student – English
Formula Student Austria - English
Formula Student Germany – English
Student Formula Japan – Japanese and English

A2.6 Competition Codes

The competition codes that must be used as part of the file names of the various documents and data that are required to be submitted electronically are:

Formula SAE Michigan - FSAEM
Formula SAE Lincoln – FSAEL
Formula SAE Lincoln – FSAEE
Formula SAE Australasia - FSAEA
Formula SAE Brazil - FSAEB
Formula SAE Italy - FSAEI
Formula Student – FS
Formula Student Austria – FSA
Formula Student Germany – FSG
Student Formula Japan – SFJ

ARTICLE 3: FORMULA SAE RULES AND ORGANIZER AUTHORITY

A3.1 Rules Authority

The Formula SAE Rules are the responsibility of the Formula SAE Rules Committee and are issued under the authority of the SAE International Collegiate Design Series Committee.

A3.1.1 Official announcements from the Formula SAE Rules Committee, SAE or the other Formula SAE organizing bodies shall be considered part of, and shall have the same validity as, these rules.

A3.1.2 Ambiguities or questions concerning the meaning or intent of these rules will be resolved by the Formula SAE Rules Committee, SAE or by the individual competition organizers as appropriate.

A3.2 Rules Validity

The Formula SAE Rules posted on the SAE website and dated for the calendar year of the competition are the rules in effect for the competition.

A3.2.1 Rule sets dated for other years are invalid.

A3.3 Rules Compliance

By entering a Formula SAE competition, the team, members of the team as individuals, faculty advisors and other personnel of the entering university agree to comply with, and be bound by, these rules and all rule interpretations or procedures issued or announced by SAE, the Formula SAE Rules Committee and the other organizing bodies.

A3.3.1 Any rules or regulations pertaining to the use of the competition site by teams or individuals and which are posted, announced and/or otherwise publicly available are incorporated into the FSAE Rules by reference. As examples, all event site waiver requirements, speed limits, parking and facility use rules apply to FSAE participants.

A3.3.2 All team members, faculty advisors and other university representatives are required to cooperate with, and follow all instructions from, competition organizers, officials and judges.

A3.4 Understanding the Rules

Teams, team members as individuals and faculty advisors, are responsible for reading and understanding the rules in effect for the competition in which they are participating.

A3.5 Participating in the Competition

Teams, team members as individuals, faculty advisors and other representatives of a registered university who are present on-site at a competition are considered to be “participating in the competition” from the time they arrive at the event site until they depart the site at the conclusion of the competition or earlier by withdrawing.

A3.6 Violations on Intent

The violation of intent of a rule will be considered a violation of the rule itself.

A3.6.1 Questions about the intent or meaning of a rule may be addressed to the Formula SAE Rules Committee or by the individual competition organizers as appropriate.
(See ARTICLE 10:)

A3.7 Right to Impound

SAE and other competition organizing bodies reserve the right to impound any onsite registered vehicles at any time during a competition for inspection and examination by the organizers, officials and technical inspectors.

A3.8 Restriction on Vehicle Use

Teams are cautioned that the vehicles designed in compliance with these Formula SAE Rules are intended for competition operation only at the official Formula SAE competitions.

A3.9 Headings

The article, section and paragraph headings in these rules are provided only to facilitate reading: they do not affect the paragraph contents.

A3.10 General Authority

SAE and the competition organizing bodies reserve the right to revise the schedule of any competition and/or interpret or modify the competition rules at any time and in any manner that is, in their sole judgment, required for the efficient operation of the event or the Formula SAE series as a whole.

A3.11 SAE Technical Standards Access

A cooperative program of SAE's Education Board and Technical Standards Board is making some of SAE's Technical Standards available to teams registered for any North American CDS competition at no cost. The Technical Standards referenced in the Collegiate Design Series rules, along with other standards with reference value, will be accessible online to registered teams, team members and faculty advisors. To access the standards (1) your team must be registered for a competition in North America and (2) the individual team member or faculty advisor wanting access must be linked to the team in SAE's system.

Access Procedure - Once your team has registered there will be a link to the technical standards titled "Design Standards" on the main registration screen where all the required onsite registration information is added. On the technical standards webpage, you will have the ability to search standards either by J-number assigned or a topic of interest such as brake light.

A list of accessible SAE Technical Standards can be found in Appendix S.

ARTICLE 4: INDIVIDUAL PARTICIPATION REQUIREMENTS

A4.1 Eligibility Limits

Eligibility is limited to undergraduate and graduate students to ensure that this is an engineering design competition.

A4.2 Student Status

Team members must be enrolled as degree seeking undergraduate or graduate students in the college or university of the team with which they are participating. Team members who have graduated during the seven (7) month period prior to the competition remain eligible to participate.

Teams which are formed with members from two or more Universities are treated as a single team. A student at any University making up the team may compete at any event where the team participates. The multiple Universities are in effect treated as one University and all eligibility requirements (one car per competition class, one registration slot, etc.) are enforced.

A4.3 Society Membership

Team members must be members of at least one of the following societies: (1) SAE International, (2) SAE Australasia, (3) SAE Brazil, (4) ATA, (5) IMechE, (6) VDI, or (7) JSAE. Proof of membership, such as membership card, is required at the competition.

NOTE: Students can join SAE online at: www.sae.org/students

A4.4 Age

Team members must be at least eighteen (18) years of age.

A4.5 Driver's License

Team members who will drive a competition vehicle at any time during a competition must hold a valid, government issued driver's license.

A4.6 Liability Waiver

All on-site participants, including students, faculty and volunteers, are required to sign a liability waiver upon registering on-site.

A4.7 Medical Insurance

Individual medical insurance coverage is required and is the sole responsibility of the participant.

A4.8 Individual Registration Requirements for North American Competitions – ACTION REQUIRED

A4.8.1 All students and faculty, both domestic and international, if you have an SAE International membership, make sure you are affiliated to your respective school/ college/ university on the SAE website under your "MySAE".

A4.8.2 If you are not a member of SAE International or other approved societies, you will need to join SAE International online at www.sae.org. Select the "Join /Renew/Upgrade" link under the Membership tab, and then select "Professional or Student". Students will need to select the "Student Membership" link and then follow the series of the questions that are asked. Faculty that wishes to be SAE members should choose the "Professional Membership" link and proceed to the series of questions. Please note all student participants must be SAE International members to participate in the event. It is not mandatory for faculty to join.

A4.8.3 All international student participants (or unaffiliated faculty advisors) who are not SAE International members are required to create a free customer account profile on www.sae.org. Upon completion, please email CollegiateCompetitions@sae.org their assigned customer number stating also the event and university affiliation.

A4.8.4 **Online registration information is required!** Every participant, including advisors must affiliate themselves and complete the following information on under the team's registration page on the SAE website www.sae.org:

- Emergency contact data (point of contact (parent/guardian, spouse), relationship, and phone number)

To do this you will need to go to "Registration" page under the specific event the team is registered and then click on the "Register Your Team / Update Team Information" link. At this point, if you are properly affiliated to the school/college/university, a link will appear with your team name to select. Once you have selected the link, the registration page will appear. Selecting the "Add New Member" button will allow individuals to include themselves with the rest of the team. This can also be completed by team captain and faculty advisor for all team members.

All students, both domestic and international, must affiliate themselves online by January 31 of the year of the competition. For additional assistance, please contact CollegiateCompetitions@sae.org.

A4.9 Onsite Registration Requirement

ONSITE REGISTRATON IS REQUIRED OF ALL TEAM MEMBERS AND FACULTY ADVISORS.

Bring your (1) Government issued driver's license or passport and (2) your medical insurance card or documentation to onsite registration.

ARTICLE 5: FACULTY ADVISOR, ELECTRICAL SYSTEM OFFICER AND ELECTRICAL SYSTEM ADVISOR

A5.1 Faculty Advisor

- A5.1.1 Each team is expected to have a Faculty Advisor appointed by the university. The Faculty Advisor is expected to accompany the team to the competition and will be considered by competition officials to be the official university representative.
- A5.1.2 Faculty Advisors may advise their teams on general engineering and engineering project management theory.
- A5.1.3 Faculty Advisors may not design any part of the vehicle nor directly participate in the development of any documentation or presentation.

Additionally, Faculty Advisors may not fabricate nor assemble any components nor assist in the preparation, maintenance, testing or operation of the vehicle.

In Brief – Faculty Advisors may not design, build or repair any part of the car.

A5.2 Electrical System Officer – Electric Teams only

- A5.2.1 Every participating team has to appoint at least one electrical system officer (ESO) for the event. This person is responsible for all electrical operations of the vehicle during the event.
- A5.2.2 The ESO is responsible for every kind of work at the car during the event.
- A5.2.3 The ESO is the only person in the team that is allowed to declare the car electrically safe, so that work on any system of the car may be performed by the team.
- A5.2.4 The ESO must be a valid team member, which means that he/she has to have student status, see A4.2.
- A5.2.5 The ESO must be contactable by phone at all times during the event.
- A5.2.6 The ESO must accompany the car whenever operated or is moved around at the event site.
- A5.2.7 The ESO is not allowed to be a driver, if no second ESO is named by the team who is not a driver.
- A5.2.8 The ESO must be properly qualified.
The ESO must be certified or must have received appropriate practical training whether formal or informal for working with high voltage systems in automotive vehicles. Details of the training must be provided to the organizers on the ESO/ESA form for approval.

A5.3 Electric System Advisor – Electric Teams only

- A5.3.1 The Electrical System Advisor (ESA) must be a professionally competent person(s) nominated by the Entrant who can advise on the electrical and control systems that will be integrated into the vehicle. It is acceptable for the faculty advisor to be the ESA if all the requirements below are met.
- A5.3.2 The ESA must supply details of their experience of electrical and/or control systems engineering as employed in the car on the ESO/ESA form for approval by the organizers. It is likely that the ESA will be a Chartered Engineer or someone of equivalent status.

A5.3.3 The ESA must have significant experience of the technology that is being developed and its implementation into vehicles or other safety critical systems such that they are adequately qualified to advise the team on their proposed electrical and control system designs.

NOTE: It may be necessary to have more than one person to achieve this requirement.

A5.3.4 The ESA must advise the team such that the merits of any relevant engineering solutions can be discussed, questioned and approved before being implemented into the final vehicle design.

A5.3.5 The ESA should advise the students on the required training such that they are competent to work with the systems on the vehicle.

A5.3.6 The ESA(s) must review and sign the Electrical System Form and FMEA documents to confirm that in principle the vehicle has been designed using good engineering practices.

A5.3.7 The ESA must ensure that the team discusses any unusual aspects of the design with the rules committee to reduce the risk of exclusion or significant changes being required to pass technical inspection.

ARTICLE 6: VEHICLE ELIGIBILITY

A6.1 Student Developed Vehicle

Vehicles entered into Formula SAE competitions must be conceived, designed, fabricated and maintained by the student team members without direct involvement from professional engineers, automotive engineers, racers, machinists or related professionals.

A6.2 Information Sources

The student team may use any literature or knowledge related to car design and information from professionals or from academics as long as the information is given as a discussion of alternatives with their pros and cons.

A6.3 Professional Assistance

Professionals may not make design decisions or drawings and the Faculty Advisor may be required to sign a statement of compliance with this restriction.

A6.4 Student Fabrication

It is the intent of the SAE Collegiate Design Series competitions to provide direct hands-on experience to the students. Therefore, students should perform all fabrication tasks whenever possible.

A6.5 The Formula SAE Competition Year – First Year Cars

For the purpose of defining first, second and third year cars, a competition “year” is any consecutive run of the Series, i.e. Formula SAE Michigan, Formula SAE Lincoln, Formula Student, Formula Student Austria, Formula Student Germany, Formula SAE Italy, Formula SAE BRASIL, Student Formula Japan and Formula SAE Australasia held within a roughly 12-month period counting from the event in which a vehicle first competes. For example, a car that competes first in Formula SAE Australasia is classified as a “first year car” until the following year’s Formula SAE Australasia competition.

NOTE: Teams are reminded that their vehicles must comply with the rules in effect for each competition they enter.

A6.6 First Year Vehicles – North American Formula SAE Competitions

A6.6.1 Only first year vehicles may enter the Formula SAE Competitions in North America.

A6.6.2 To be classified as a “first year vehicle” a car must, as a minimum, have a completely new frame or monocoque. Photographic or other evidence will be used to determine if the frame is new.

A6.6.3 If there is any question about whether or not the car is in fact a first year vehicle, it will be the sole responsibility of the team to produce such evidence as the organizers or judges may require.

A6.7 Second Year Vehicles – North American Formula SAE Competitions

Vehicles that have competed during any previous “Formula SAE Year” as defined in A6.5 are prohibited from Formula SAE competitions held in North America.

A6.8 First Year Vehicles: FSAE-A, FSAE-B, FSAE-I, Formula Student, Formula Student Germany and Formula Student Austria and Student Formula Japan

A6.8.1 To be classified as a “first year vehicle” a car must, as a minimum, have a completely new frame or monocoque. Photographic or other evidence will be used to determine if the frame is new.

A6.8.2 If there are any questions about whether or not the car is in fact a first year vehicle, it will be the sole responsibility of the team to produce such evidence as the organizers or judges may require.

A6.9 Second Year Vehicles: FSAE-A and FSAE-B

A6.9.1 Vehicles that have competed during any one (1) previous Formula SAE year may compete provided that they have been substantially modified from their first appearance. Photographic and design documentation detailing the modifications are required along with a statement from the team’s Faculty Advisor.

A6.9.2 Penalties for insufficient redesign or insufficient knowledge by the team will be applied during the Design Event. Refer to the Rule S6.15 “Penalties for Insufficient Redesign”.

A6.10 Third Year Vehicles –Prohibited

A6.10.1 Vehicles that have competed in any two (2) previous Formula SAE years are prohibited from participating in any Formula SAE competition.

A6.10.2 Any team found to have entered a vehicle that contravenes this rule will be disqualified. Additionally, the team will be required to submit such documentation as the organizers may require in advance of the acceptance of any future registration.

ARTICLE 7: REGISTRATION

A7.1 Registration – North American Formula SAE Competitions

Registration for Formula SAE competitions held in North America must be completed on-line. Online registration must be done by either (a) an SAE member or (b) the official faculty advisor connected with the registering university and recorded as such in the SAE record system.

NOTE: It typically takes at least 1 working day between the time you complete an on-line SAE membership application and our system recognizes you as eligible to register your team.

Check the individual competition websites for exact registration requirements for events outside North America.

A7.2 Entries per University – North American Formula SAE Competitions – Registering IC and EV Teams – For the purposes of registering and competing, a school’s IC team and EV team are considered to be separate and independent entities. A university may register both an IC Team and an EV team in the same competition.

A7.3 Registration Limits - North American Formula SAE Competitions
Registration limits for the North American Formula SAE competitions will be posted on the SAE website.

Registration for each FSAE competitions closes as soon as the registration limit is reached. We strongly advise teams to register as soon as registration opens.

A7.4 Registration Dates – North American Formula SAE Competitions
Registration for the North American Formula SAE competitions will open at the date and time posted on the competition website.

For the first month of the registration period a team may enter either FSAE Michigan or FSAE Lincoln, but not both.

Registration into Formula SAE Electric does not have a lock-out period and is not affected by registration into FSAE Michigan or FSAE Lincoln.

After the first month of registration any untaken slots at any of the competitions will be available to any team on a first come, first serve basis.

Registration for the North American Formula SAE competitions will close at the date and time posted on the competition website or when all the registration slots have been taken, whichever occurs first.

There are no exceptions to this registration policy.

A7.5 Registration Fees

A7.5.1 Registration fees must be paid to the organizer by the deadline specified on the respective competition website.

A7.5.2 Registration fees are not refundable and may not be transferred to a subsequent year’s competition.

A7.6 Waitlist (North American Formula SAE Competitions Only)

A7.6.1 Once an event fills all registered team slots a waitlist option will be open for teams that are not already registered for the competition. The waitlist is capped at 40 available spaces per event and will close on the same day as registration. Once a team withdraws from the competition, an SAE International staff member will inform the team by email (the individual who registered the team to the waitlist) that a spot on the registered list has opened. You will have 24 hours to accept or reject the position and an additional 24 hours to have the registration payment completed or in process.

A7.6.2 Waitlisted teams are required to submit all documents by the same deadlines as registered teams in order to be eligible for an open registered team slot.

A7.7 Withdrawals

A7.7.1 Registered teams that find that they will not be able to attend the competition are requested to officially withdraw by notifying the following:

A7.7.2 Formula SAE North American Event withdrawals: Kaley Zundel, kzundel@sae.org

A7.7.3 For events outside North America, please visit the respective competition website for contact information.

A7.8 United States Visas

Teams requiring visas to enter to the United States are advised to apply at least sixty (60) days prior to the competition. Although most visa applications seem to go through without an unreasonable delay, occasionally teams have had difficulties and in several instances visas were not issued before the competition.

Don't wait – apply early for your visa.

After your team has registered for an SAE organized FSAE competition then SAE can provide an acknowledgement your registration. We do not issue letters of invitation.

Neither SAE staff nor any competition organizers are permitted to give advice on visas, customs regulations or vehicle shipping regulations concerning the United States or any other country.

A7.9 Vehicle Shipping

Vehicle shipments by commercial carrier must comply with the laws and regulations of nations from which, and to which, the car is being sent. Teams are advised to consult with their shipping company or freight forwarder to be sure their shipment fully complies with all relevant, customs, import/export and aviation shipping requirements.

Shipments must be sent with the sending team or university listed as the receiving party. Neither the competition organizers nor the competition sites can be listed as the receiving party.

Vehicle shipping procedures for the North American competitions are published on the Formula SAE website for each event and are incorporated into these Rules by reference.

A7.10 On-site Registration

All team members and faculty advisors must complete the on-site registration procedures immediately after they arrive at the competition site.

On-site registration must be completed and the credentials and/or other identification issued by the organizers properly worn before the car can be unloaded, uncrated or worked upon in any manner.

ARTICLE 8: VEHICLE DOCUMENTATION, DEADLINES AND PENALTIES

A8.1 Required Documents and Required Forms

The following documents supporting each vehicle must be submitted by the action deadlines posted on each competition website or otherwise published by the organizers.

A8.1.1 The following forms are located at <http://fsaeonline.com>

- ARTICLE 5: “Electrical Systems Officer and Electrical Systems Advisor Form”
- T3.9 “Structural Equivalency Spreadsheet (SES)” and Appendix B-1
- T3.21 “Impact Attenuator Data Requirement”
- AF2 “Structural Requirements Certification Form (SRCF)”
- PART IC - IC1.18 ETC - Failure Modes and Effects Analysis (FMEA)

- PART EV - EV9.1 “Electrical System Form”
- PART EV - EV9.2 “Failure Modes and Effects Analysis”
- PART S - ARTICLE 3: “Business Logic Plan”
- S6.3 “Design Spec Sheet”

A8.1.2 The following report submissions must comply with the specific rules for their event:

- PART S - ARTICLE 4: “Cost Report”
- S6.2 “Design Report”

A8.1.3 Check the relevant website for the competition your team is entering for the following:

- PART IC - IC1.17 ETC – Notice of Intent
- PART IC - IC2.1 “Fuel” – Some competitions require a fuel type order
- Program Submissions – Material required for programs is specific to each competition.

A8.2 Deadlines

Volunteer judges evaluate all the required submissions and it is essential that they have enough time to complete their work. There are no exceptions to the document submission deadlines and late submissions will incur penalties. Please note that different documents or submissions may have different deadlines – check the event websites.

A8.3 Submission Addresses and Formats

The procedures for submitting documents and the websites and/or addresses to which the various documents should be sent are published on the individual event websites or otherwise released by the organizers. Most required documents must be submitted in a format specified in the individual event rules or using a prescribed form. Failure to submit a document in the proper format, or with an incorrect file name, will be considered as “Not Submitted.”

Carefully read the event rules and check the website of the competition you are entering.

Notice - Teams will **not** be notified if a document is submitted incorrectly. Each team is responsible for confirming that its documents have been properly uploaded and that the deadlines have been met. Email confirmations to teams are **not** sent

A8.4 Late Submission Penalties

Documents or submissions that are received or uploaded after the deadline, or are submitted largely incomplete within the deadline, will receive a point penalty per day, or partial day, based on the time difference between the deadline and the actual date and time of receipt or upload, subject to official discretion.

The applicable point penalties and maximum penalties are shown in the following steps.

A8.4.1 Tech and Business Submission Penalty

Penalty Per Day	-10 points
Maximum Penalty	-50 points

- Electrical Systems Officer and Electrical Systems Advisor Form A5.2 and A5.3
- Structural Equivalency Spreadsheet (SES) T3.9
- Impact Attenuator Report (IAD) T3.21

- Structural Requirements Certification Form (SRCF) Part AF – Article 2
- Electrical System Form (ESF) EV9.1
- Failures Modes and Effects Analysis (FMEA) EV9.2
- Business Logic Plan (BLC) Part S – Article 3

A8.4.2 Design Event Submission Penalty

Penalty Per Day	-10 points
Maximum Penalty	-100 points
Not Submitted	Removed from Design Event and Score Zero points

- Design Report and/or Design Spec Sheet S6.8

A8.4.3 Cost Event Submission Penalty

Penalty Per Day	-10 points
Maximum Penalty	-80 points
Not Submitted	-100 points and Removed from Cost Event

- Cost Report S4.16

A8.4.4 IC2.1 Fuel – There is no point penalty for late submission of a fuel type order, however once the deadline has passed your team will be allocated the basic fuel type.

A8.4.5 Program Submissions – Program submission requirements differ across competitions and may or may not involve penalties. Please submit program material by the published deadlines.

A8.4.6 Withdrawal of Team Entry. The organizer may withdraw the team entry if the identified documents are not submitted within 10 days of the deadline. The team will be notified prior to canceling registration. No refund of entry fees will be given. This elimination will take place after each round of required document deadlines.

A8.5 Web Based Submission – North American Events Only

Teams entering Formula SAE Michigan, FSAE Lincoln, and FSAE Electric must submit the following documents online through <http://fsaeonline.com/>:

- A5 Electric Vehicles Only “Electrical Systems Officer and Electrical Systems Advisor Form”
- T3.9 “Structural Equivalency Spreadsheet (SES)” and Appendix B-1
- or AF2 “Structural Requirements Certification Form (SRCF)”
- T3.21 “Impact Attenuator Data Requirement”
- S3 “Business Logic Plan”
- S6.2 “Design Report”
- S6.3 “Design Spec Sheet”
- EV9.1 Electric vehicles only - “Electrical System Form”
- EV9.2 Electric vehicles only - “Failure Modes and Effects Analysis”

*For 2017 Formula SAE Competitions in United States, Cost Report Submission process may be changed. Please refer to the website for additional announcements and information.

The date/time of upload to CDS Web constitutes the official record for deadline compliance.

Documents may be uploaded to the website from the time your fsaeonline.com account has been created and accepted (See A8.6) until the “Submission Due Date” deadline. Submissions may be replaced with new uploads at any point during that period without penalty.

Documents uploaded between the “Submission Due Date” and the “No Submissions Accepted After” deadline are classified as late submissions and the appropriate penalties will be applied.

No submissions will be allowed after the “No Submissions Accepted After” deadline unless the uploaded document is specifically requested by the reviewer of technical documents required to pass technical inspection – for example – IAD, SES, ESF, FMEA and ESO/ESA at which point there is no penalty point assessed.

A8.6 Account Signup for Online Submission – North American Events Only

Account creation for online document submission through fsaeonline requires the following steps:

- a. Visit <http://fsaeonline.com/>
- b. Follow the account signup instructions on the website. Select “Your Affiliation” as either “Team Captain/Team Advisor” or “Team Member (non-captain)”
- c. Your “authentication number” for fsaeonline signup is the SAE confirmation number that was issued when your team registered.

NOTE - There may be a delay of up to three (3) business days between the time your team registers for a competition and the fsaeonline site recognizes the validity of your authentication number and the team captain may create an account.

Once your team captain has created an account it will remain valid until your team becomes dormant or no longer registers to compete.

d. Responsibilities and Restrictions

Team Captain Role – Each team must have at least one person identified on fsaeonline as the Team Captain. The Team Captain(s) has unique responsibilities on the site including accepting other team members for site access. Until the captain accepts a member’s signup that person cannot upload or view team documents. Team captains automatically have the same roles and privileges as their team members.

Team Member Restrictions – Team members must be approved by the Team Captain or the Faculty Advisor before being able to view or upload team documents.

Uploading Documents – All team members and the team captain have equal authority to upload and/or replace documents in the name of the team.

Document Access – Uploaded documents can only be viewed by (1) members of the submitting team, (2) authorized judges, technical inspectors and officials and (3) CDS staff.

Reminder – The website does not know what you intended to submit or what you thought you were doing. Anything your team uploads to the site is considered to be an official action by your team.

NOTE – Not all team members need to be affiliated on the fsaeonline website; however, team members responsible for submitting documents by the deadlines must be added.

Transfer of Team Captain Responsibility – Important – If your captain is leaving the team, through graduation or otherwise, it is important that the departing captain “pass the baton” by designating one, or more, new captains on the FSAEonline website. Only your team captain(s) has the authority to add team members and new/additional captains. Please note that your team can designate more than one captain. But before you do so, remember that all your captains will have equivalent authority on the fsaeonline website.

ARTICLE 9: PROTESTS

- A9.1** It is recognized that thousands of hours of work have gone into fielding a vehicle and that teams are entitled to all the points they can earn. We also recognize that there can be differences in the interpretation of rules, the application of penalties and the understanding of procedures. The officials and SAE staff will make every effort to fully review all questions and resolve problems and discrepancies quickly and equitably.
- A9.2 Preliminary Review – Required**
If a team has a question about scoring, judging, policies or any official action it must be brought to the organizer’s or SAE staff’s attention for an informal preliminary review before a protest can be filed.
- A9.3 Cause for Protest**
A team may protest any rule interpretation, score or official action (unless specifically excluded from protest) which they feel has caused some actual, non-trivial, harm to their team, or has had a substantive effect on their score. Teams may not protest rule interpretations or actions that have not caused them any substantive damage.
- A9.4 Protest Format and Forfeit**
All protests must be filed in writing and presented to the organizer or SAE staff by the team captain. In order to have a protest considered, a team must post a twenty-five (25) point protest bond which will be forfeited if their protest is rejected.
- A9.5 Protest Period**
Protests concerning any aspect of the competition must be filed within the protest period announced by the competition organizers or one-half hour (30 minutes) of the posting of the scores of the event to which the protest relates.
- A9.6 Decision**
The decision of the competition protest committee regarding any protest is final.

ARTICLE 10: QUESTIONS ABOUT THE FORMULA SAE RULES

- A10.1 Question Publication**
By submitting a question to the FSAE Rules Committee or the competition’s organizing body you and your team agree that both your question and the official answer can be reproduced and distributed by SAE, in both complete and edited versions, in any medium or format anywhere in the world.
- A10.2 Question Types**
The Committee will answer questions that are not already answered in the rules or FAQs or that require new or novel rule interpretations. The Committee will not respond to questions that are

already answered in the rules. For example, if a rule specifies a minimum dimension for a part the Committee will not answer questions asking if a smaller dimension may be used.

A10.3 Frequently Asked Questions

Before submitting a question, check the Frequently Asked Questions section of the Formula SAE Forum website.

A10.4 Question Format

A10.4.1 All rules questions must include (1) the full name and email address of the student submitting the question, (2) the name of the university – no abbreviations, (3) the number of the applicable rule and (4) the specific competition your team has, or is planning to, enter.

A10.4.2 The following limits apply to questions submitted to the FSAE Rules Committee (1) No photograph, drawing or other attachment may exceed 500 KB in size (2) the total size of any question, with all attachments, must not exceed 2 MB.

A10.5 Response Time

A10.5.1 Please allow a minimum of two (2) weeks for a response. The Rules Committee will respond as quickly as possible, however responses to questions presenting new issues, or of unusual complexity, may take more than two weeks.

A10.5.2 Please do not resend questions.

A10.6 Submission Addresses:

A10.6.1 Teams entering Formula SAE competitions in North America:
Follow the current submission instructions published on fsaeonline.com by going to [http://fsaeonline.com/](http://fsaeonline.com) and clicking "Submit a Rules Question" on the Quick Links menu on the right.

A10.6.2 Teams entering competitions outside North American please visit those respective competition websites for further instructions.



APPENDIX A – SAE TECHNICAL STANDARDS

The SAE Technical Standards Board (TSB) has made the following SAE Technical Standards available on line, **at no cost**, for use by Collegiate Design teams. Standards are important in all areas of engineering and we urge you to review these documents and to become familiar with their contents and use.

The technical documents listed below include both (1) standards that are identified in the rules and (2) standards that the TSB and the various rules committees believe are valuable references or which may be mentioned in future rule sets.

All Collegiate Design Series teams registered for competitions in North America have access to all the standards listed below - including standards not specific to your competition.

See FSAE Rule A3.11 “Technical Standards Access” for the access procedure.

SAE Technical Standards included in the CDS Rules

Baja SAE

J586 - Stop Lamps for Use on Motor Vehicles Less Than 2032 mm in Overall Width
J759 - Lighting Identification Code
J994 - Alarm - Backup – Electric Laboratory Tests
J1741 - Discriminating Back-Up Alarm Standard

Clean Snowmobile Challenge

J192 - Maximum Exterior Sound Level for Snowmobiles
J1161 - Sound Measurement – Off-Road Self-Propelled Work Machines Operator-Work Cycle

Formula SAE Hybrid

J1318 - Gaseous Discharge Warning Lamp for Authorized Emergency, Maintenance and Service Vehicles
J1673 - High Voltage Automotive Wiring Assembly Design

Formula SAE

SAE 4130 steel is referenced but no specific standard is identified
SAE Grade 5 bolts are required but no specific standard is identified

Supermileage

J586 - Stop Lamps for Use on Motor Vehicles Less Than 2032 mm in Overall Width

Electric Standards

SAE Technical Standards for Supplemental Use

Standards Relevant to Baja SAE

J98 – Personal Protection for General Purpose Industrial Machines – Standard
J183 – Engine Oil Performance and Engine Service Classification - Standard
J306 – Automotive Gear Lubricant Viscosity Classification - Standard
J429 – Mechanical and Material Requirements for Externally Threaded Fasteners – Standard
J512 – Automotive Tube Fittings - Standard
J517 – Hydraulic Hose - Standard
J1166 – Sound Measurement – Off-Road Self-Propelled Work Machines Operator-Work Cycle
J1194 – Rollover Protective Structures (ROPS) for Wheeled Agricultural Tractors

- J1362 – Graphical Symbols for Operator Controls and Displays on Off-Road Self-Propelled Work Machines - Standard
- J1614 – Wiring Distribution Systems for Construction, Agricultural and Off-Road Work Machines
- J1703 - Motor Vehicle Brake Fluid - Standard
- J2030 – Heavy Duty Electrical Connector Performance Standard
- J2402 – Road Vehicles – Symbols for Controls, Indicators and Tell-Tales – Standard

Standards Relevant to Clean Snowmobile Challenge

- J44 – Service Brake System Performance Requirements – Snowmobiles - Recommended Practice
- J45 – Brake System Test Procedure – Snowmobiles – Recommended Practice
- J68 – Tests for Snowmobile Switching Devices and Components - Recommended Practice
- J89 – Dynamic Cushioning Performance Criteria for Snowmobile Seats - Recommended Practice
- J92 – Snowmobile Throttle Control Systems – Recommended Practice
- J192 – Maximum Exterior Sound Level for Snowmobiles - Recommended Practice
- J288 – Snowmobile Fuel Tanks - Recommended Practice
- J1161 – Operational Sound Level Measurement Procedure for Snowmobiles - Recommended Practice
- J1222 – Speed Control Assurance for Snowmobiles - Recommended Practice
- J1279 – Snowmobile Drive Mechanisms - Recommended Practice
- J1282 – Snowmobile Brake Control Systems - Recommended Practice
- J2567 – Measurement of Exhaust Sound Levels of Stationary Snowmobiles - Recommended Practice

Standards Relevant to Formula SAE

- J183 – Engine Oil Performance and Engine Service Classification - Standard
- J306 – Automotive Gear Lubricant Viscosity Classification - Standard
- J429 – Mechanical and Material Requirements for Externally Threaded Fasteners – Standard
- J452 - General Information – Chemical Compositions, Mechanical and Physical Properties of SAE Aluminum Casting Alloys – Information Report
- J512 – Automotive Tube Fittings - Standard
- J517 – Hydraulic Hose - Standard
- J637 – Automotive V-Belt Drives – Recommended Practice
- J829 – Fuel Tank Filler Cap and Cap Retainer
- J1153 - Hydraulic Cylinders for Motor Vehicle Brakes – Test Procedure
- J1154 – Hydraulic Master Cylinders for Motor Vehicle Brakes - Performance Requirements - Standard
- J1703 - Motor Vehicle Brake Fluid - Standard
- J2045 – Performance Requirements for Fuel System Tubing Assemblies - Standard
- J2053 – Brake Master Cylinder Plastic Reservoir Assembly for Road Vehicles – Standard

Standard Relevant to Formula Hybrid

- J1772 – SAE Electric Vehicle and Plug in Hybrid Conductive Charge Coupler

Standard Relevant to all CDS Competitions

- J1739 – Potential Failure Mode and Effects Analysis in Design (Design FMEA) Potential Failure Mode and Effects Analysis in Manufacturing and Assembly Processes (Process FMEA) and Potential Failure Mode and Effects Analysis for Machinery (Machinery FMEA)

2017-18 FORMULA SAE RULES

PART T - GENERAL TECHNICAL REQUIREMENTS

ARTICLE 1: VEHICLE REQUIREMENTS & RESTRICTIONS

T1.1 Technical Inspection

The following requirements and restrictions will be enforced through technical inspection. Noncompliance must be corrected and the car re-inspected before the car is allowed to operate under power.

T1.2 Modifications and Repairs

T1.2.1 Once the vehicle has been presented for judging in the Cost or Design Events, or submitted for Technical Inspection, and until the vehicle is approved to compete in the dynamic events, i.e. all the inspection stickers are awarded, the only modifications permitted to the vehicle are those directed by the Inspector(s) and noted on the Inspection Form.

T1.2.2 Once the vehicle is approved to compete in the dynamic events, the ONLY modifications permitted to the vehicle are those listed below. They are also referred to in PART S - Static Event Regulations.

- a. Adjustment of belts, chains and clutches
- b. Adjustment of brake bias
- c. Adjustment of the driver restraint system, head restraint, seat and pedal assembly
- d. Substitution of the head restraint or seat insert for different drivers
- e. Adjustment to engine operating parameters, e.g. fuel mixture and ignition timing, and any software calibration changes
- f. Adjustment of mirrors
- g. Adjustment of the suspension where no part substitution is required, (except that springs, sway bars and shims may be changed)
- h. Adjustment of tire pressure
- i. Adjustment of wing angle, but not the location
- j. Replenishment of fluids
- k. Replacement of worn tires or brake pads. Replacement tires and brake pads must be identical in material/composition/size to those presented and approved at Technical Inspection.
- l. The changing of wheels and tires for “wet” or “damp” conditions as allowed in PART D - Dynamic Event Regulations.
- m. Recharging low voltage batteries
- n. Recharging high voltage accumulators

T1.2.3 The vehicle must maintain all required specifications, e.g. ride height, suspension travel, braking capacity (pad material/composition), sound level and wing location throughout the competition.

T1.2.4 Once the vehicle is approved for competition, any damage to the vehicle that requires repair, e.g. crash damage, electrical or mechanical damage will void the Inspection Approval. Upon the completion of the repair and before re-entering into any dynamic competition, the vehicle MUST be re-submitted to Technical Inspection for re-approval.

ARTICLE 2: GENERAL DESIGN REQUIREMENTS

T2.1 Vehicle Configuration

The vehicle must be open-wheeled and open-cockpit (a formula style body) with four (4) wheels that are not in a straight line.

Definition of "Open Wheel" – Open Wheel vehicles must satisfy all of the following criteria:

- a. The top 180 degrees of the wheels/tires must be unobstructed when viewed from vertically above the wheel.
- b. The wheels/tires must be unobstructed when viewed from the side.
- c. No part of the vehicle may enter a keep-out-zone defined by two lines extending vertically from positions 75mm in front of and 75mm behind, the outer diameter of the front and rear tires in the side view elevation of the vehicle, with tires steered straight ahead. This keep-out zone will extend laterally from the outside plane of the wheel/tire to the inboard plane of the wheel/tire. See the figure "Keep Out Zones" below.
- d. Must also comply with the dimensions/requirements of ARTICLE 9: Aerodynamic Devices.

The dry tires will be used for all inspections.

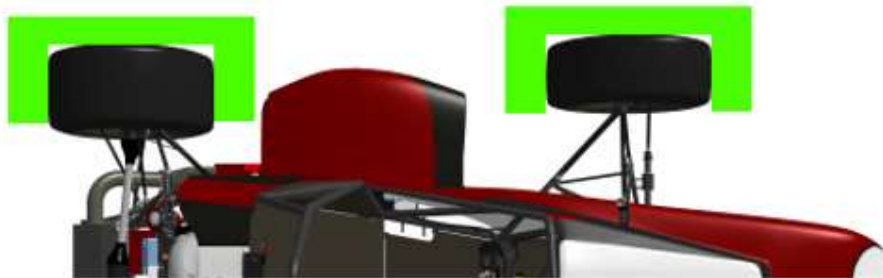
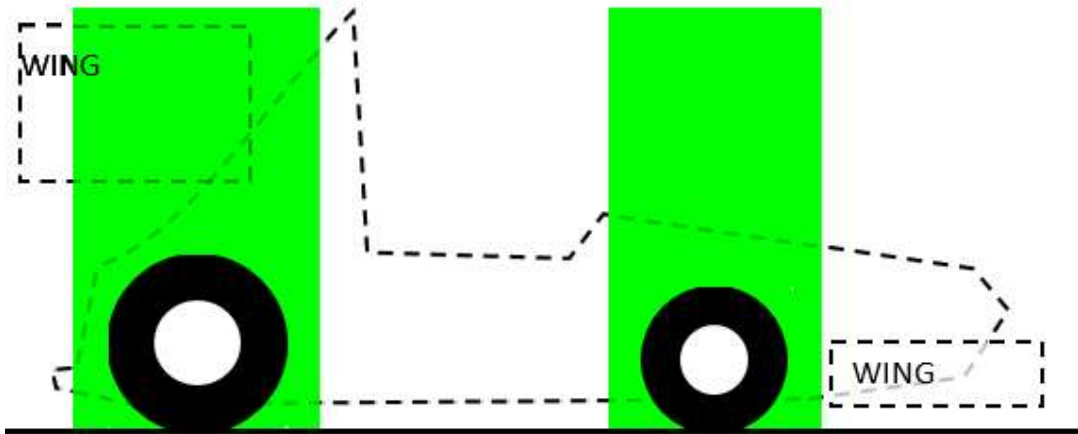

T2.2 Bodywork

There must be no openings through the bodywork into the driver compartment from the front of the vehicle back to the roll bar main hoop or firewall other than that required for the cockpit opening. Minimal openings around the front suspension components are allowed.

T2.3 Wheelbase

The car must have a wheelbase of at least 1525 mm (60 inches). The wheelbase is measured from the center of ground contact of the front and rear tires with the wheels pointed straight ahead.

T2.4 Vehicle Track

The smaller track of the vehicle (front or rear) must be no less than 75% of the larger track.

T2.5 Visible Access

All items on the Inspection Form must be clearly visible to the technical inspectors without using instruments such as endoscopes or mirrors. Visible access may be provided by removing body panels or by providing removable access panels.

ARTICLE 3: DRIVER'S CELL

T3.1 Vehicle Structure - 2 Options

Teams may, at their option, design their vehicle to comply with either of two (2) separate, but related, sets of requirements and restrictions. Specifically, teams may elect to comply with **either**:

- a. Part T Article 3 "Drivers Cell" as defined below **or**
- b. Part AF "Alternate Frame Rules" as found in Appendix AF and the FSAE website.

T3.1.1 Notice Requirement – Teams planning to use the Part AF "Alternate Frame Rules" must notify the Rules Committee of their intent by the date posted on the SAE Website. The instructions for notification appear in Part AF. The Rules Committee will review the submission and notify the team if the request is granted. Part AF has significant analytical requirements and this application process will insure that the Committee can handle the workload and give teams the support they may require to show certification as well as insure the teams have the technical capability to analyze their design and prove compliance with the AF Rules.

T3.1.2 Alternate Frame Rules use requires the submission of the "Structural Requirements Certification Form (SRCF)" which **supersedes portions of** the "Structural Equivalency Spreadsheet". See AF Articles 7 and 8 for a list of superseded T3 Driver Cells and EV Article 3 rules.

T3.2 General Requirements

Among other requirements, the vehicle's structure must include two roll hoops that are braced, a front bulkhead with support system and Impact Attenuator, and side impact structures.

T3.3 Definitions

The following definitions apply throughout the Rules document:

- a. Main Hoop - A roll bar located alongside or just behind the driver's torso.
- b. Front Hoop - A roll bar located above the driver's legs, in proximity to the steering wheel.
- c. Roll Hoops – Both the Front Hoop and the Main Hoop are classified as "Roll Hoops"
- d. Roll Hoop Bracing Supports – The structure from the lower end of the Roll Hoop Bracing back to the Roll Hoop(s).
- e. Frame Member - A minimum representative single piece of uncut, continuous tubing.
- f. Frame - The "Frame" is the fabricated structural assembly that supports all functional vehicle systems. This assembly may be a single welded structure, multiple welded structures or a combination of composite and welded structures.
- g. Primary Structure – The Primary Structure is comprised of the following Frame components:
 - i. Main Hoop,
 - ii. Front Hoop,
 - iii. Roll Hoop Braces and Supports,
 - iv. Side Impact Structure,
 - v. Front Bulkhead,
 - vi. Front Bulkhead Support System and
 - vii. All Frame Members, guides and supports that transfer load from the Driver's Restraint System into items 1 through 6.
- h. Major Structure of the Frame – The portion of the Frame that lies within the envelope defined by the Primary Structure. The portion of the Main Hoop above a horizontal plane located at the top of the upper side impact bar and the Main Hoop Bracing are not included in defining this envelope.

- i. Front Bulkhead – A planar structure that defines the forward plane of the Major Structure of the Frame and functions to provide protection for the driver’s feet.
- j. Impact Attenuator – A deformable, energy absorbing device located forward of the Front Bulkhead.
- k. Side Impact Zone – The area of the side of the car extending from the top of the floor to 350 mm (13.8 inches) above the ground and from the Front Hoop back to the Main Hoop.
- l. Node-to-node triangulation – An arrangement of frame members projected onto a plane, where a co-planar load applied in any direction, at any node, results in only tensile or compressive forces in the frame members. This is also what is meant by “properly triangulated”.

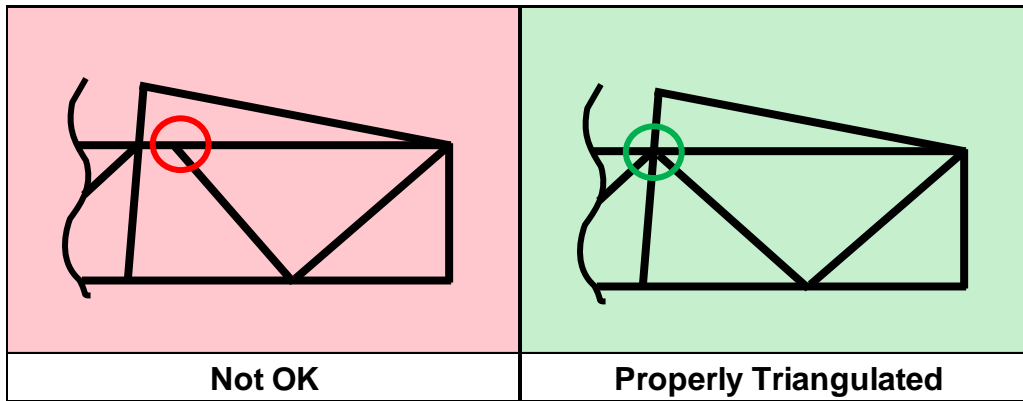

T3.4 Minimum Material Requirements

T3.4.1 Baseline Steel Material

The Primary Structure of the car must be constructed of:

Either: Round, mild or alloy, steel tubing (minimum 0.1% carbon) of the minimum dimensions specified in the following table,

Or: Approved alternatives per Rules T3.5, T3.6 and T3.7.

ITEM or APPLICATION	OUTSIDE DIMENSION X WALL THICKNESS
Main & Front Hoops, Shoulder Harness Mounting Bar	Round 1.0 inch (25.4 mm) x 0.095 inch (2.4 mm) or Round 25.0 mm x 2.50 mm metric
Side Impact Structure, Front Bulkhead, Roll Hoop Bracing, Driver’s Restraint Harness Attachment (except as noted above) EV: Accumulator Protection Structure	Round 1.0 inch (25.4 mm) x 0.065 inch (1.65 mm) or Round 25.0 mm x 1.75 mm metric or Round 25.4 mm x 1.60 mm metric or Square 1.00 inch x 1.00 inch x 0.047 inch or Square 25.0 mm x 25.0 mm x 1.20 mm metric
Front Bulkhead Support, Main Hoop Bracing Supports, Shoulder Harness Mounting Bar Bracing EV: Tractive System Components Protection	Round 1.0 inch (25.4 mm) x 0.047 inch (1.20 mm) or Round 25.0 mm x 1.5 mm metric or Round 26.0 mm x 1.2 mm metric
Bent Upper Side-Impact Member (T3.24.3a)	Round 1.375 inch (35.0mm) x 0.047 inch (1.20mm)

T3.4.2 The use of alloy steel does not allow the wall thickness to be thinner than that used for mild steel.

- T3.4.3 The following items in a specific application are NOT rules deviations and do not require approval:
- Using tubing of the specified outside diameter but with greater wall thickness
 - Using tubing of the specified wall thickness and a greater outside diameter
 - Replacing round tubing with square tubing of the same or larger size to those listed above

T3.4.4 Except for inspection holes, any holes drilled in any regulated tubing require the submission of an SES.

T3.4.5 Steel properties used for calculations to be submitted in an SES or SRCF must be the following:

Non-Welded strength for continuous material calculations:

Young's Modulus (E) = 200 GPa (29,000 ksi)

Yield Strength (Sy) = 305 MPa (44.2 ksi)

Ultimate Strength (Su) = 365 MPa (52.9 ksi)

Welded strength for discontinuous material such as joint calculations:

Yield Strength (Sy) = 180 MPa (26ksi)

Ultimate Strength (Su) = 300 MPa (43.5 ksi)

Where welded tubing reinforcements are required (e.g. inserts for bolt holes or material to support suspension cutouts) the tubing must retain the baseline cold rolled strength while using the welded strength for the additional reinforcement material.

T3.4.6 Any tubing smaller than 1"x0.047" (or an approved alternative as per Rules T3.5, T3.6 or T3.7) is not considered structural and will be ignored when assessing compliance to any rule listed within Part T.

T3.4.7 Any tubing thickness less than 0.047" (or an approved alternative as per Rules T3.5, T3.6 or T3.7) is not considered structural and will be ignored when assessing compliance to any rule.

T3.5 Alternative Tubing, Tubing Geometry and Materials - General Notes for all Applications

T3.5.1 Alternative tubing geometry and/or materials may be used except that the Main Roll Hoop and Main Roll Hoop Bracing must be made from steel, i.e. the use of aluminum or titanium tubing or composites for these components is prohibited.

T3.5.2 Titanium or magnesium on which welding has been utilized may not be used for any part of the Primary Structure. This includes the attachment of brackets to the tubing or the attachment of the tubing to other components.

T3.5.3 If a team chooses to use alternative tubing and/or materials, they must submit a "Structural Equivalency Spreadsheet" per Rule T3.9. The teams must submit calculations for the material they have chosen, demonstrating equivalence to the minimum requirements found in Section T3.4.1 for yield and ultimate strengths in bending, buckling and tension, for buckling modulus and for energy dissipation. (The Buckling Modulus is defined as EI, where, E = modulus of Elasticity, and I = area moment of inertia about the weakest axis.)

T3.5.4 Tubing must meet or exceed the minimum wall thickness listed in T3.6 or T3.7.

T3.5.5 If a bent tube (or member consisting of multiple tubes that are not in a line) is used anywhere in the primary structure, other than the front and main roll hoops, an additional tube must be attached to support it. The attachment point must be the position along the tube where it deviates farthest from a straight line connecting both ends. The support tube must have the same diameter and thickness as the bent tube, terminate at a node of the chassis, and be angled no more than 30 degrees from the

plane of the bent tube. **Braces attached to the upper side impact member are not required to meet the 30 degrees from the plane of the bent tube requirement.**

T3.5.6 Any chassis design that is a hybrid of the baseline and monocoque rules, must meet all relevant rules requirements, e.g. a sandwich panel side impact structure in a tube frame chassis must meet the requirements of rules T3.27, T3.28, T3.29, T3.30 and T3.33.

It is allowable for the properties of tubes and laminates to be combined to prove equivalence. For example, in a side-impact structure consisting of one tube as per T3.4 and a laminate panel, the panel only needs to be equivalent to two side-impact tubes.

T3.6 Alternative Steel Tubing

Minimum Wall Thickness Allowed

MATERIAL & APPLICATION	MINIMUM WALL THICKNESS
Steel Tubing for Front and Main Roll Hoops, and Shoulder Harness Mounting Bar	2.0 mm (0.079 inch)
Steel Tubing for Roll Hoop Bracing, Roll Hoop Bracing Supports, Side Impact Structure, Front Bulkhead, Front Bulkhead Support, Driver’s Harness Attachment (except as noted above), Protection of HV accumulators, and protection of HV tractive systems	1.2 mm (0.047 inch)

Minimum Wall Thickness Allowed for teams satisfying physical testing requirements:

MATERIAL & APPLICATION	MINIMUM WALL THICKNESS
Steel Tubing for Front and Main Roll Hoops, and Shoulder Harness Mounting Bar	1.6 mm (0.065 inch)
Steel Tubing for Roll Hoop Bracing, Roll Hoop Bracing Supports, Side Impact Structure, Front Bulkhead, Front Bulkhead Support, Driver’s Harness Attachment (except as noted above), Protection of HV accumulators, and protection of HV tractive systems	0.9 mm (0.035 inch)

- a. All steel is treated equally - there is no allowance for alloy steel tubing, e.g. SAE 4130, to have a thinner wall thickness than that used with mild steel.
- b. To maintain EI with a thinner wall thickness than specified in T3.4.1, the outside diameter **MUST** be increased.
- c. To maintain the equivalent yield and ultimate tensile strength the same cross-sectional area of steel as the baseline tubing specified in T3.4.1 **MUST** be maintained.
- d. Teams using the Alternative Frame Rules must comply with rule T3.6.

T3.6.1 Test samples representing the joining method to be used on the Primary Structure must be constructed by team members and pull tested to determine joint strength and quality.

T3.6.2 Test samples must be constructed in an “H” pattern with two parallel 203mm (8 inches) long tubes separated by 38mm (1.5 inches) measured from the tube centerline. The connecting tube must be perpendicular to the parallel tubes and be 50mm (2 inches) from the top end of one tube and 50mm (2 inches) from the bottom end of the other tube.

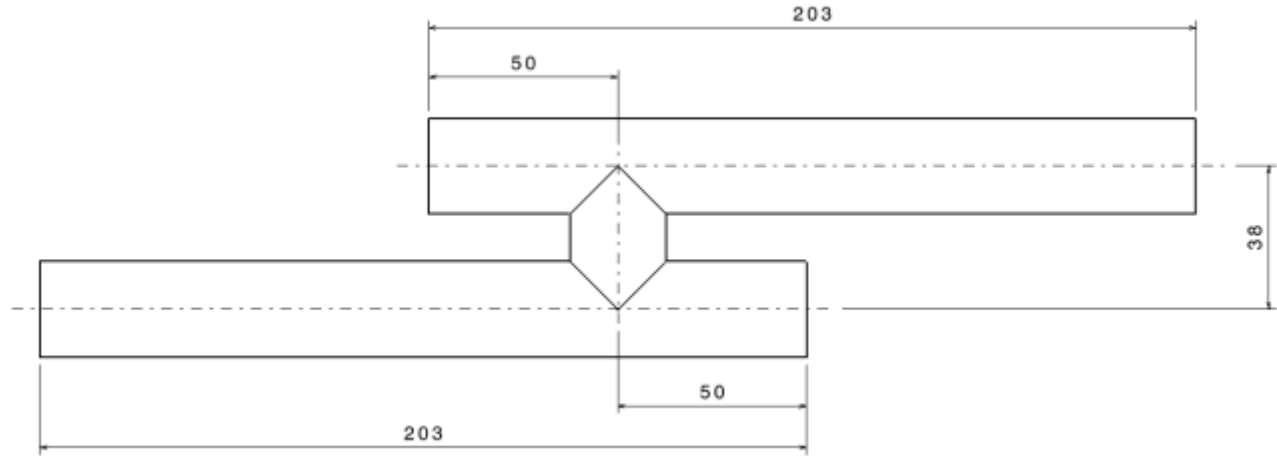

- T3.6.3 Construction of the test samples must meet the following requirements:
- The test samples must use the same mild/alloy steel as is used in the construction of the chassis.
 - For each alternative configuration that is used in the vehicle design both the alternative and baseline must be tested and compared.
 - Two samples of each joint must be manufactured and tested, two each of the baseline and two each of the alternative joint. **NOTE:** this means the minimum number of tests is four.

Baseline joint			Alternate tube thickness joint	
inches	metric		inches	metric
1"x0.095" to 1"x0.047"	25.4mm x 2.4 mm to 25.4mm x 1.2 mm	-->	1"x0.095" to 1.375"x0.035"	25.4mm x 2.4 mm to 34.9mm x 0.9 mm
1"x0.063" to 1"x0.047"	25.4mm x 1.6 mm to 25.4mm x 1.2 mm	-->	1"x0.063" to 1.375"x0.035"	25.4mm x 1.6 mm to 34.9mm x 0.9 mm
1"x0.047" to 1"x0.047"	25.4mm x 1.2 mm to 25.4mm x 1.2 mm	-->	1"x0.047" to 1.375"x0.035"	25.4mm x 1.2 mm to 34.9mm x 0.9 mm
1"x0.047" to 1"x0.047"	25.4mm x 1.2 mm to 25.4mm x 1.2 mm	-->	1.375"x0.035" to 1.375"x0.035"	34.9mm x 0.9 mm to 34.9mm x 0.9 mm

- The thinnest wall thickness tube must be the short perpendicular tube between the parallel tubes.
- Teams may modify or add material at the ends of the test samples for mounting into a pull test machine. Mounting end modifications must be consistent across all test samples.
- Any post welding heat treatment such as annealing must be consistent across all test samples and with the actual vehicle frame. Altering the shape of the weld is not allowed (no grinding or sanding).

T3.6.4 Test samples must be pull tested to failure. Force vs. Deflection curves for all samples must be submitted for review in the SES. The “physical test requirement” is satisfied if the minimum failure load for both "Alternate tube thickness" test samples is within 95 percent of the minimum failure load of either corresponding "Baseline joint" test sample. Test results must be documented in the SES or SRCF and test samples must be available to technical inspectors at competition

T3.7 Aluminum Tubing Requirements

T3.7.1 Minimum Wall Thickness: Aluminum Tubing 3.0 mm (0.118 inch)

T3.7.2 The equivalent yield strength must be considered in the “as-welded” condition, (Reference: WELDING ALUMINUM (latest Edition) by the Aluminum Association, or THE WELDING HANDBOOK, Volume 4, 7th Ed., by The American Welding Society), unless the team demonstrates and shows proof that the frame has been properly solution heat treated and artificially aged.

T3.7.3 Should aluminum tubing be solution heat-treated and age hardened to increase its strength after welding; the team must supply sufficient documentation as to how the process was performed. This includes, but is not limited to, the heat-treating facility used, the process applied, and the fixturing used.

T3.8 Composite Materials

T3.8.1 If any composite or other material is used, the team must:

- Present documentation of material type, e.g. purchase receipt, shipping document or letter of donation, and of the material properties.

- Submit details of the composite lay-up technique as well as the structural material used (cloth type, weight, and resin type, number of layers, core material, and skin material if metal).

- Submit calculations demonstrating equivalence of their composite structure to one of similar geometry made to the minimum requirements found in Section T3.4.1. Equivalency calculations must be submitted for energy dissipation, yield and ultimate strengths in bending, buckling, and tension. Submit the completed “Structural Equivalency Spreadsheet” per Section T3.9.

T3.8.2 Composite materials are not allowed for the Main Hoop or the Front Hoop.

T3.9 Structural Documentation – SES or SRCF Submission

All equivalency calculations must prove equivalency relative to steel grade SAE/AISI 1010.

T3.9.1 All teams MUST submit either a STRUCTURAL EQUIVALENCY SPREADSHEET (SES) or a STRUCTURAL REQUIREMENTS CERTIFICATION FORM (SRCF).

Teams complying with the Part T Article 3 “Drivers Cell” rules MUST submit a Structural Equivalence Spreadsheet (SES), even if they are NOT planning to use alternative materials or tubing sizes to those specified in T3.4.1 Baseline Steel Materials.

Teams following the Part AF “Alternate Frame Rules” MUST submit a Structural Requirements Certification Form (SRCF). See Rule Part AF - AF2.1.

T3.9.2 The use of alternative materials or tubing sizes to those specified in T3.4.1 “Baseline Steel Material,” is allowed, provided they have been judged by a technical review to have equal or superior properties to those specified in T3.4.1.

T3.9.3 Approval of alternative material or tubing sizes will be based upon the engineering judgment and experience of the chief technical inspector or his appointee.

T3.9.4 The technical review is initiated by completing the “Structural Equivalency Spreadsheet” (SES) using the format given in Appendix T-1.

T3.9.5 Structural Equivalency Spreadsheet – Submission

- a. Address – SESs must be submitted to the officials at the competition you are entering at the address shown in the Appendix or indicated on the competition website.
- b. Due Date – SESs must be submitted no later than the date indicated on the competition website. Penalties for Late Submission will be imposed per A8.4.1. SES/SRCF forms are evaluated in the order in which they are received with late submissions reviewed last. Please submit SES/SRCF as early as possible to reduce the chance of late SES/SRCF approval which could delay the completion of your vehicle.
- c. Acknowledgement – North America competitions – SESs submitted for vehicles entered into competitions held in North America will be acknowledged automatically by the fsaonline website.

Do Not Resubmit SES's unless instructed to do so.

T3.9.6 Vehicles completed under an approved SES must be fabricated in accordance with the materials and processes described in the SES.

T3.9.7 Teams must bring a copy of the approved SES with them to Technical Inspection.

Comment - The resubmission of an SES that was written and submitted for a competition in a previous year is strongly discouraged. Each team is expected to perform their own tests and to submit SESs based on their original work. Understanding the engineering that justifies the equivalency is essential to discussing your work with the officials.

T3.10 Main and Front Roll Hoops – General Requirements

T3.10.1 The driver's head and hands must not contact the ground in any rollover attitude.

T3.10.2 The Frame must include both a Main Hoop and a Front Hoop as shown in Figure 1.

T3.10.3 When seated normally and restrained by the Driver's Restraint System, the helmet of a 95th percentile male (anthropometrical data) and all of the team's drivers must:

- a. Be a minimum of 50.8 mm (2 inches) from the straight line drawn from the top of the main hoop to the top of the front hoop. (Figure 1a)
- b. Be a minimum of 50.8 mm (2 inches) from the straight line drawn from the top of the main hoop to the lower end of the main hoop bracing if the bracing extends rearwards. (Figure 1b)
- c. Be no further rearwards than the rear surface of the main hoop if the main hoop bracing extends forwards. (Figure 1c)

A two-dimensional template used to represent the 95th percentile male is made to the following dimensions:

- A circle of diameter 200 mm (7.87 inch) will represent the hips and buttocks.
- A circle of diameter 200 mm (7.87 inch) will represent the shoulder/cervical region.
- A circle of diameter 300 mm (11.81 inch) will represent the head (with helmet).
- A straight line measuring 490 mm (19.29 inch) will connect the centers of the two 200 mm circles.
- A straight line measuring 280 mm (11.02 inch) will connect the centers of the upper 200 mm circle and the 300 mm head circle.

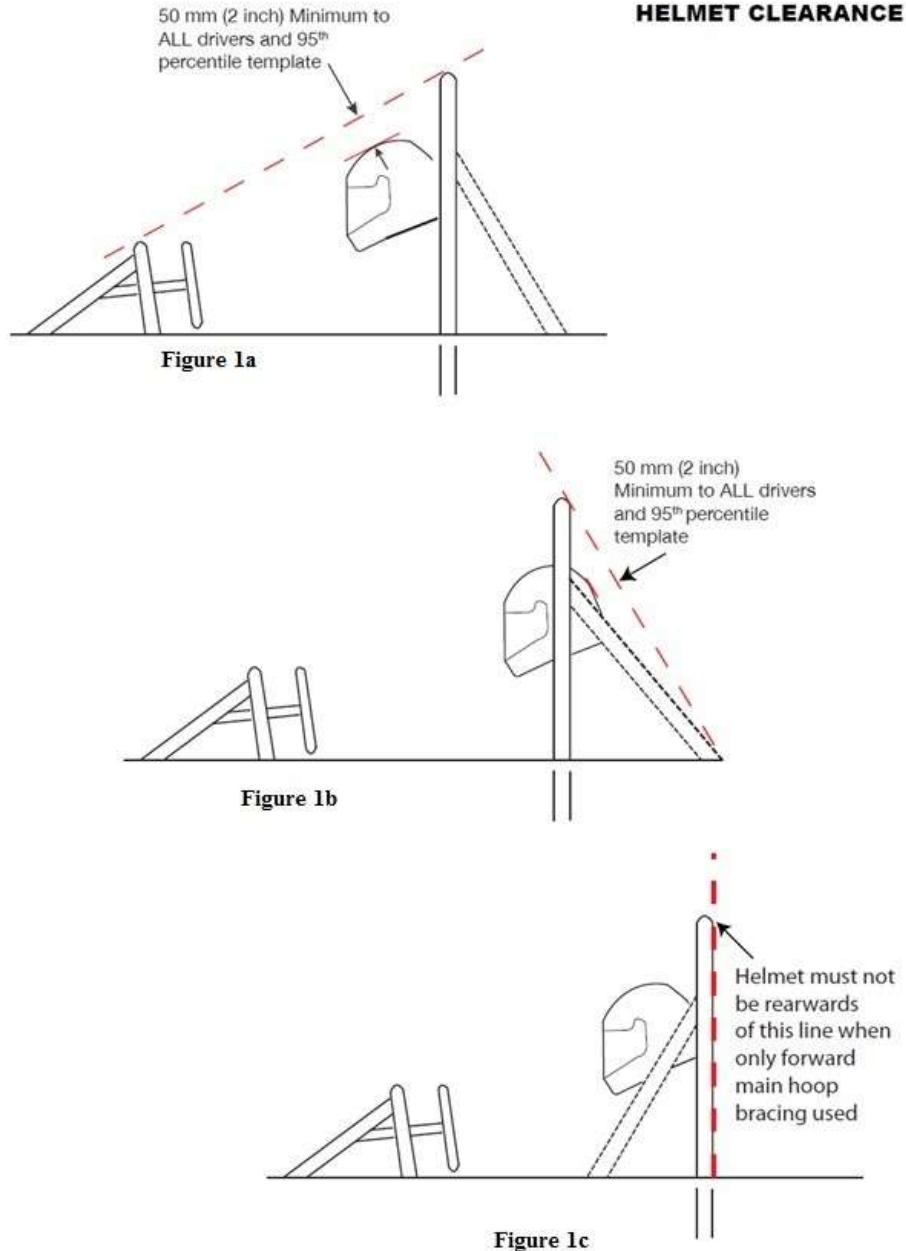

T3.10.4 The 95th percentile male template will be positioned as follows: (See Figure 2.)

- a. The seat will be adjusted to the rearmost position,
- b. The pedals will be placed in the most forward position.
- c. The bottom 200 mm circle will be placed on the seat bottom such that the distance between the center of this circle and the rearmost face of the pedals is no less than 915 mm (36 inches).
- d. The middle 200 mm circle, representing the shoulders, will be positioned on the seat back.
- e. The upper 300 mm circle will be positioned no more than 25.4 mm (1 inch) away from the head restraint (i.e. where the driver's helmet would normally be located while driving).

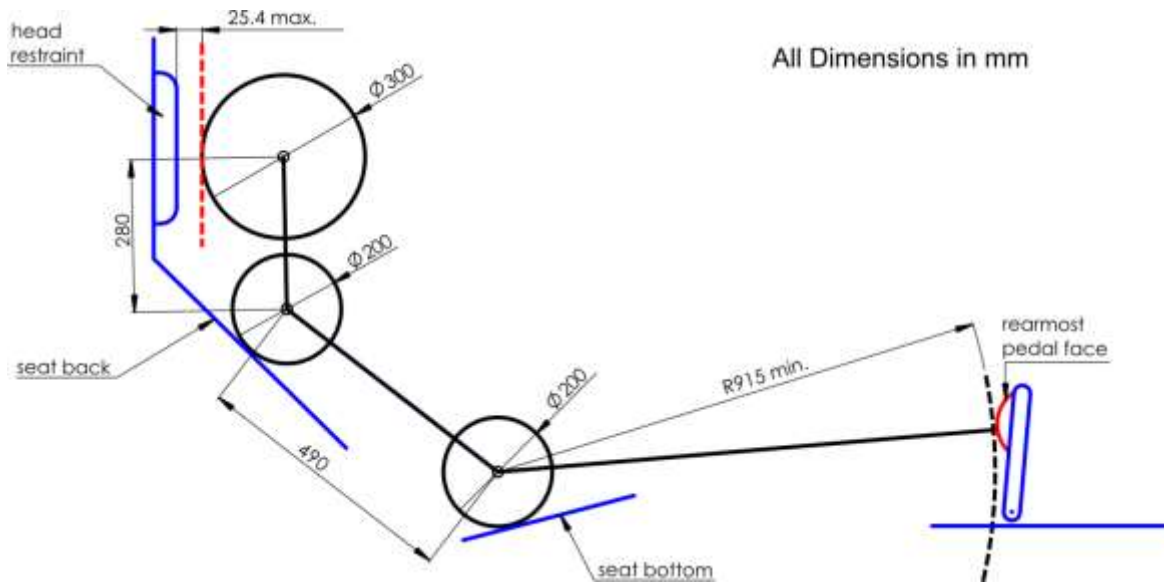

Figure 2

- T3.10.5 If the requirements of T3.10.4 are not met with the 95th percentile male template, the car will NOT receive a Technical Inspection Sticker and will not be allowed to compete in the dynamic events.
- T3.10.6 Drivers who do not meet the helmet clearance requirements of T3.10.3 will not be allowed to drive in the competition.
- T3.10.7 The minimum radius of any bend, measured at the tube centerline, must be at least three times the tube outside diameter. Bends must be smooth and continuous with no evidence of crimping or wall failure.
- T3.10.8 The Main Hoop and Front Hoop must be securely integrated into the Primary Structure using proper triangulation.
- T3.11 Main Hoop**
- T3.11.1 The Main Hoop must be constructed of a single piece of uncut, continuous, closed section steel tubing per Rule T3.4.1.
- T3.11.2 The use of aluminum alloys, titanium alloys or composite materials for the Main Hoop is prohibited.
- T3.11.3 The Main Hoop must extend from the lowest Frame Member on one side of the Frame, up, over and down the lowest Frame Member on the other side of the Frame.
- T3.11.4 In the side view of the vehicle, the portion of the Main Roll Hoop that lies above its attachment point to the upper Side Impact Tube, must be within ten degrees (10°) of the vertical.
- T3.11.5 In the side view of the vehicle, any bends in the Main Roll Hoop above its attachment point to the Major Structure of the Frame must be braced to a node of the Main Hoop Bracing Support structure with tubing meeting the requirements of Roll Hoop Bracing as per Rule T3.4.1.
- T3.11.6 In the side view of the vehicle, the portion of the Main Roll Hoop that lies below the upper side impact member attachment point may be inclined at any angle to the vertical in the forward direction but, it must be inclined rearward no more than ten degrees (10°) of the vertical.

T3.11.7 In the front view of the vehicle, the vertical members of the Main Hoop must be at least 380 mm (15 inch) apart (inside dimension) at the location where the Main Hoop is attached to the bottom tubes of the Major Structure of the Frame.

T3.12 Front Hoop

T3.12.1 The Front Hoop must be constructed of closed section metal tubing per Rule T3.4.1.

T3.12.2 The Front Hoop must extend from the lowest Frame Member on one side of the Frame, up, over and down to the lowest Frame Member on the other side of the Frame.

T3.12.3 With proper triangulation, it is permissible to fabricate the Front Hoop from more than one piece of tubing.

T3.12.4 The top-most surface of the Front Hoop must be no lower than the top of the steering wheel in any angular position.

T3.12.5 The Front Hoop must be no more than 250 mms (9.8 inches) forward of the steering wheel. This distance must be measured horizontally, on the vehicle centerline, from the rear surface of the Front Hoop to the forward most surface of the steering wheel rim with the steering in the straight-ahead position.

T3.12.6 In side view, the Front Hoop or any part of it must be inclined no more than twenty degrees (20°) from the vertical.

T3.13 Main Hoop Bracing

T3.13.1 Main Hoop braces must be constructed of closed section steel tubing per Rule T3.4.1.

T3.13.2 The Main Hoop must be supported by two braces extending in the forward or rearward direction on both the left and right sides of the Main Hoop.

T3.13.3 In the side view of the Frame, the Main Hoop and the Main Hoop braces must not lie on the same side of the vertical line through the top of the Main Hoop, i.e. if the Main Hoop leans forward, the braces must be forward of the Main Hoop, and if the Main Hoop leans rearward, the braces must be rearward of the Main Hoop.

T3.13.4 The Main Hoop braces must be attached as near as possible to the top of the Main Hoop but not more than 160 mm (6.3 in) below the top-most surface of the Main Hoop. The included angle formed by the Main Hoop and the Main Hoop braces must be at least thirty degrees (30°). See Figure 3.

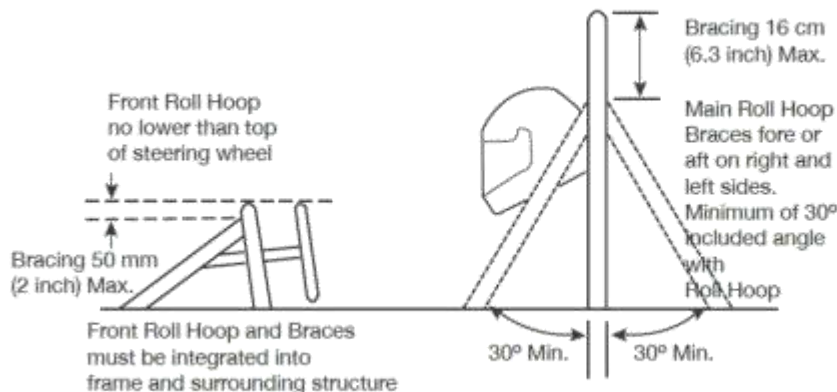

FIGURE 3

- T3.13.5 The Main Hoop braces must be straight, i.e. without any bends.
- T3.13.6 The Main Hoop Braces must be securely integrated into the Frame and be capable of transmitting all loads from the Main Hoop into the Major Structure of the Frame without failing.
- T3.13.7 The lower end of the Main Hoop Braces must be supported back to the Main Hoop by a minimum of two Frame Members on each side of the vehicle; an upper member and a lower member in a properly triangulated configuration.
- The upper support member must attach to the node where the upper Side Impact Member attaches to the Main Hoop.
 - The lower support member must attach to the node where the lower Side Impact Member attaches to the Main Hoop.

Each of the above members may be multiple or bent tubes provided the requirements of T3.5.5 are met.

Examples of acceptable configurations of members may be found in Appendix T-4.

- T3.13.8 All the Frame Members of the Main Hoop Bracing Support system listed above must be constructed of closed section tubing per Section T3.4.1.
- T3.13.9 If any item which is outside the envelope of the Primary Structure is attached to the Main Hoop braces, then additional bracing must be added to prevent bending loads in the braces in any rollover attitude

T3.14 Front Hoop Bracing

- T3.14.1 Front Hoop braces must be constructed of material per Rule T3.4.1.
- T3.14.2 The Front Hoop must be supported by two braces extending in the forward direction on both the left and right sides of the Front Hoop.
- T3.14.3 The Front Hoop braces must be constructed such that they protect the driver's legs and should extend to the structure in front of the driver's feet.
- T3.14.4 The Front Hoop braces must be attached as near as possible to the top of the Front Hoop but not more than 50.8 mm (2 in) below the top-most surface of the Front Hoop. See Figure 3.
- T3.14.5 If the Front Hoop leans rearwards by more than ten degrees (10°) from the vertical, it must be supported by additional bracing to the rear. This bracing must be constructed of material per Rule T3.4.1.
- T3.14.6 The driver's feet and legs must be completely contained within the Major Structure of the Frame. While the driver's feet are touching the pedals, in side and front views, any part of the driver's feet or legs must not extend above or outside of the Major Structure of the Frame.
- T3.14.7 The Front Hoop braces must be straight, i.e. without any bends

T3.15 Other Bracing Requirements

Where the braces are not welded to steel Frame Members, the braces must be securely attached to the Frame using 8 mm Metric Grade 8.8 (5/16 in SAE Grade 5), or stronger, bolts. Mounting plates welded to the Roll Hoop braces must be at least 2.0 mm (0.080 in) thick steel.

T3.16 Other Side Tube Requirements

If there is a Roll Hoop brace or other frame tube alongside the driver, at the height of the neck of any of the team’s drivers, a metal tube or piece of sheet metal must be firmly attached to the Frame to prevent the drivers’ shoulders from passing under the roll hoop brace or frame tube, and his/her neck contacting this brace or tube.

T3.17 Mechanically Attached Roll Hoop Bracing

T3.17.1 Roll Hoop bracing may be mechanically attached.

T3.17.2 Any non-permanent joint at either end must be either a double-lug joint as shown in Figures 4 and 5, or a sleeved butt joint as shown in Figure 6.

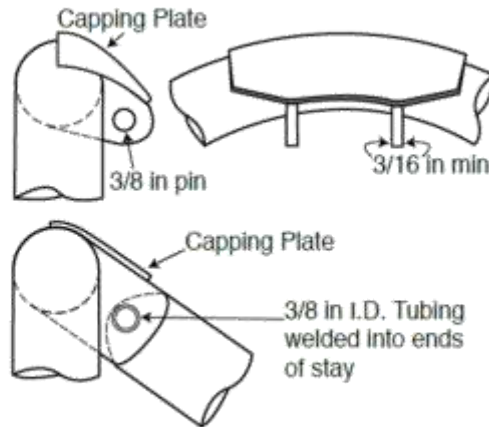

FIGURE 4

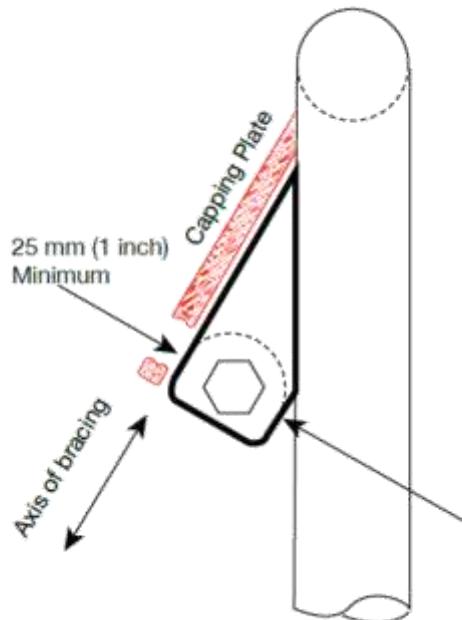
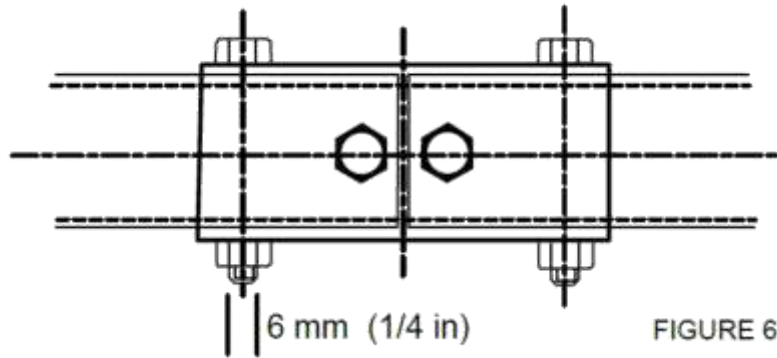

FIGURE 5



- T3.17.3 The threaded fasteners used to secure non-permanent joints are considered critical fasteners and must comply with ARTICLE 11:
- T3.17.4 No spherical rod ends are allowed.
- T3.17.5 For double-lug joints, each lug must be at least 4.5 mm (0.177 in) thick steel, measure 25 mm (1.0 in) minimum perpendicular to the axis of the bracing and be as short as practical along the axis of the bracing.
- T3.17.6 All double-lug joints, whether fitted at the top or bottom of the tube, must include a capping arrangement (Figures 4 & 5).
- T3.17.7 In a double-lug joint the pin or bolt must be 10 mm Metric Grade 9.8 (3/8 in. SAE Grade 8) minimum. The attachment holes in the lugs and in the attached bracing must be a close fit with the pin or bolt.
- T3.17.8 For sleeved butt joints (Figure 6), the sleeve must have a minimum length of 76 mm (3 inch); 38 mm (1.5 inch) either side of the joint, and be a close-fit around the base tubes. The wall thickness of the sleeve must be at least that of the base tubes. The bolts must be 6 mm Metric Grade 9.8 (1/4 inch SAE Grade 8) minimum. The holes in the sleeves and tubes must be a close-fit with the bolts.

T3.18 Bulkhead

- T3.18.1 The Front Bulkhead must be constructed of closed section tubing per Rule T3.4.1.
- T3.18.2 Except as allowed by T3.18.3, The Front Bulkhead must be located forward of all non-crushable objects, e.g. batteries, master cylinders, hydraulic reservoirs.
- T3.18.3 The Front Bulkhead must be located such that the soles of the driver's feet, when touching but not applying the pedals, are rearward of the bulkhead plane. (This plane is defined by the forward-most surface of the tubing.) Adjustable pedals must be in the forward most position.

T3.19 Front Bulkhead Support

- T3.19.1 The Front Bulkhead must be securely integrated into the Frame.
- T3.19.2 The Front Bulkhead must be supported back to the Front Roll Hoop by a minimum of three Frame Members on each side of the vehicle; an upper member; lower member and diagonal brace to provide triangulation.

- a. The upper support member must be attached within 50mm (2") of the top surface of the Front Bulkhead, and attach to the Front Roll Hoop within a zone extending 100mm (4") above and 50mm (2") below the Upper Side Impact member. **If the upper support member is further than 100mm (4") above the Upper Side Impact member, then properly triangulated bracing is required to transfer load to the Main Hoop, either via the Upper Side Impact member, or an additional member that meets the size requirements of T3.4, transmitting load from the junction of the Upper Support Member with the Front Hoop.**
- b. The lower support member must be attached to the base of the Front Bulkhead and the base of the Front Roll Hoop.
- c. The diagonal brace must properly triangulate the upper and lower support members

Each of the above members may be multiple or bent tubes provided the requirements of T3.5.5 are met.

Examples of acceptable configurations of members may be found in Appendix T-4.

T3.19.3 All the Frame Members of the Front Bulkhead Support system listed above must be constructed of closed section tubing per Section T3.4.1.

T3.20 Impact Attenuator (IA)

T3.20.1 Forward of the Front Bulkhead there must be an Impact Attenuator Assembly, consisting of an Impact Attenuator and an Anti-Intrusion Plate.

T3.20.2 The Impact Attenuator must be:

- a. At least 200 mm (7.8 in) long, with its length oriented along the fore/aft axis of the Frame.
- b. At least 100 mm (3.9 in) high and 200 mm (7.8 in) wide for a minimum distance of 200 mm (7.8 in) forward of the Front Bulkhead.
- c. Attached securely to the Anti-Intrusion Plate or directly to the Front Bulkhead.

An officially approved "standard" Impact Attenuator may be found in Appendix T-3.

T3.20.3 The Anti-Intrusion Plate must:

- a. Be a 1.5 mm (0.060 in) solid steel or 4.0 mm (0.157 in) solid aluminum plate, or an approved alternative as per T3.38.
- b. Attach securely and directly to the Front Bulkhead.
- c. Have an outer profile that meets the requirements of T3.20.5.

T3.20.4 The accepted methods of attaching the Impact Attenuator Assembly, Impact Attenuator and Anti-Intrusion Plate are:

- a. Welding, where the welds are either continuous or interrupted. If interrupted, the weld/space ratio must be at least 1:1. All weld lengths must be greater than 25 mm (1").
- b. Bolted joints, using a minimum of eight (8) 8 mm Metric Grade 8.8 (5/16" SAE Grade 5) bolts with positive locking. The distance between any two bolt centers must be at least 50 mm (2").

The Impact Attenuator may also be attached to the Anti-Intrusion Plate using a structural adhesive. The adhesive must be appropriate for use with both substrate types. Equivalency of this bonded joint to a welded or bolted joint must be documented in the team's SES submission.

All attachment types must provide adequate load paths for transverse and vertical loads in the event of off-axis impacts. Segmented foam attenuators must have all segments bonded together to prevent sliding or parallelogramming.

The attachment of the Impact Attenuator Assembly to a monocoque structure must be documented in the team's SES submission. This must prove the attachment method is equivalent to the bolted joints described above and that these bolted joints will fail before any other part of the monocoque.

T3.20.5 The requirements for the outside profile of the Impact Attenuator Assembly are dependent on the method of attachment to the Front Bulkhead:

For welded joints the profile must extend at least to the centerline of the Front Bulkhead tubes on all sides.

For bolted joints the profile must match the outside dimensions of the Front Bulkhead around the entire periphery.

T3.20.6 If a team uses the "standard" FSAE Impact Attenuator, and the outside profile of the Anti-Intrusion Plate extends beyond the "standard" Impact Attenuator by more than 25 mm (1") on any side, a diagonal or X-brace made from 1.00" x 0.049" steel tube, or an approved equivalent per T3.5, must be included in the Front Bulkhead.

Teams may choose to not brace the bulkhead, but physical testing must then be carried out to prove that the Anti-Intrusion Plate does not permanently deflect more than 25 mm (1").

T3.21 Impact Attenuator Data Requirement

T3.21.1 All teams must submit an Impact Attenuator Data Report using the Impact Attenuator Data (IAD) Template found in Appendix T-2.

The report must be submitted electronically in Adobe Acrobat ® format (*.pdf file) to the address and by the date indicated in the Action Deadlines provided on the relevant competition website.

The report must be a single file named as follows: carnumber_schoolname_competition code_IAD.pdf using your assigned car number, the complete school name and competition code (see A2.6)

e.g. 087_University of SAE_FSAEM_IAD.pdf

Penalties for Late Submission will be imposed per A8.4.1.

Impact Attenuator Reports will be evaluated by the organizers and passed to the Design Event Captain for consideration in that event.

T3.21.2 The report must include:

- a. Test data that proves that the Impact Attenuator Assembly, when mounted on the front of a vehicle with a total mass of 300 kg (661 lbs.) and impacting a solid, non-yielding impact barrier with a velocity of impact of 7.0 meters/second (23.0 ft./sec), decelerates the vehicle at a rate not exceeding 20 g's average and 40 g's peak. The energy absorbed in this event must meet or exceed 7350 Joules.

NOTE: These are the attenuator functional requirements not test requirements. Quasi-static testing is allowed.

- b. Calculations showing how the reported absorbed energy and decelerations have been derived.
- c. A schematic of the test method.
- d. Photos of the attenuator, annotated with the height of the attenuator before and after testing.

Teams using the standard Impact Attenuator are not required to submit test data with their IAD Report, but all other requirements must be included. In addition, photos of the actual attenuator and evidence that it meets the design criteria in Appendix T-3 must be appended to the report.

This may be a receipt or packing slip from the supplier.

- T3.21.3 During any test, the Impact Attenuator must be attached to the Anti-Intrusion plate using the intended vehicle attachment method.

The Impact Attenuator Assembly must be attached to a structurally representative section of the intended chassis. There must be at least 50 mm clearance rearwards of the Anti-Intrusion Plate to the test fixture.

No part of the Anti-Intrusion Plate may permanently deflect more than 25mm (1”) beyond the position of the Anti-Intrusion Plate before the test.

Teams using Impact Attenuators (typically structural noses) directly attached to the Front Bulkhead, which shortcut the load path through the bulk of the Anti-Intrusion Plate, must conduct an additional test. This test must prove that the Anti-Intrusion Plate can withstand a load of 120kN (300kg multiplied by 40g), where the load applicator matches the minimum Impact Attenuator dimensions.

NOTE 1: The 25 mm (1”) spacing represents the front bulkhead support and insures that the plate does not intrude excessively into the cockpit.

NOTE 2: A solid block of material in the shape of the front bulkhead is not “structurally representative”. The test fixture must have equivalent strength and stiffness to a baseline front bulkhead.

- T3.21.4 Dynamic testing (sled, pendulum, drop tower, etc.) of the Impact Attenuator may only be conducted at a dedicated test facility. This facility may be part of the University, but must be supervised by professional staff or the University faculty. Teams are not allowed to construct their own dynamic test apparatus.

When using acceleration data from the dynamic test, the average deceleration must be calculated based on the raw unfiltered data.

If peaks above the 40g limit are present in the data, a Channel Filter Class (CFC) 60 (100Hz) filter per SAE Recommended Practice J211 “Instrumental for Impact Test”, or a 100 Hz, 3rd order, low pass Butterworth (-3dB at 100 Hz) filter may be applied.

- T3.21.5 Quasi-static testing may be performed by teams using their University’s facilities/equipment, but teams are advised to exercise due care when performing all tests.

- T3.21.6 Teams with any non-crushable object(s) that do not meet the requirements of T3.22.2 c) must prove the combination of their Impact Attenuator Assembly and non-crushable object(s) do not exceed the peak deceleration of rule T3.21.2. Any of the following methods may be used to prove the design does not exceed 120kN:

- a. Physical testing of the Impact Attenuator Assembly including any required non-crushable object(s). See fsaeonline.com FAQs for an example of the structure to be included in the test for wings and wing mounts.
- b. Combining the peak force from physical testing of the Impact Attenuator Assembly with the failure load for the mounting of the non-crushable object(s), calculated from fastener shear and/or link buckling.

- c. Combining the “standard” Impact Attenuator peak load of 95kN with the failure load for the mounting of the non-crushable object(s), calculated from fastener shear and/or link buckling.

T3.22 Non-Crushable Objects

- T3.22.1 All non-crushable objects (e.g. batteries, master cylinders, hydraulic reservoirs) inside the primary structure must have 25 mm (1”) clearance to the rear face of the Impact Attenuator Anti-Intrusion Plate.
- T3.22.2 All non-crushable objects outside the primary structure must be either:
 - a. Included in the Impact Attenuator physical test
 - b. Subject to an analysis approach as per T3.21.6 b) or T3.21.6 c)
 - c. Mounted rearwards of an imaginary transverse vertical plane, offset forwards from the Impact Attenuator Anti-Intrusion Plate by a distance equal to the height of the crushed impact attenuator.

T3.23 Front Bodywork

- T3.23.1 Sharp edges on the forward facing bodywork or other protruding components are prohibited.
- T3.23.2 All forward facing edges on the bodywork that could impact people, e.g. the nose, must have forward facing radii of at least 38 mm (1.5 inches). This minimum radius must extend to at least forty-five degrees (45°) relative to the forward direction, along the top, sides and bottom of all affected edges.

T3.24 Side Impact Structure for Tube Frame Cars

The Side Impact Structure must meet the requirements listed below.

- T3.24.1 The Side Impact Structure for tube frame cars must be comprised of at least three (3) tubular members located on each side of the driver while seated in the normal driving position, as shown in Figure 7.

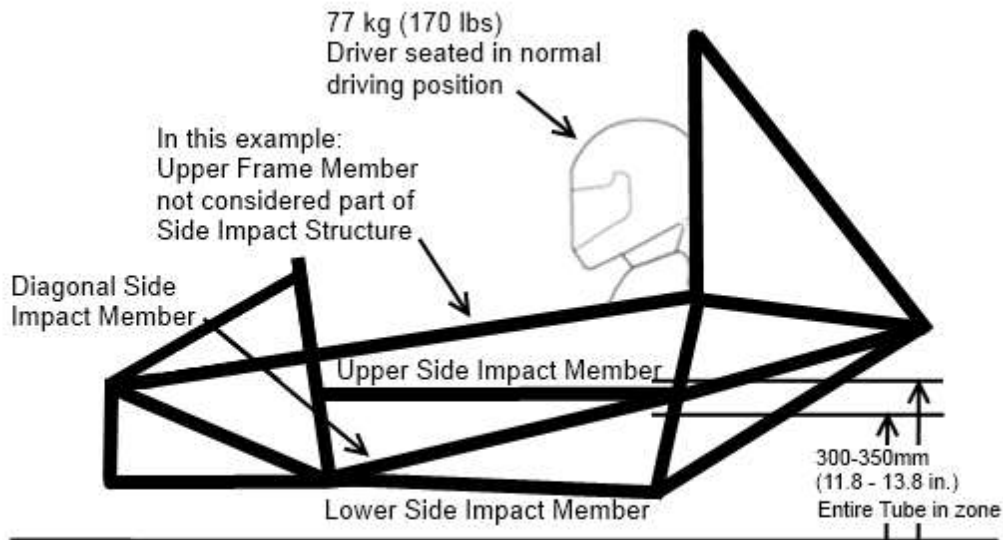

FIGURE 7

- T3.24.2 The three (3) required tubular members must be constructed of material per Section T3.4.
- T3.24.3 The locations for the three (3) required tubular members are as follows:
 - a. The upper Side Impact Structural member must connect the Main Hoop and the Front Hoop. With a 77kg (170 pound) driver seated in the normal driving position all of the member must be at a height between 300 mm (11.8 inches) and 350 mm (13.8 inches) above the ground. The

upper frame rail may be used as this member if it meets the height, diameter and thickness requirements.

If the member is bent or non-continuous, the minimum tube size must be 1 3/8" x 0.047" (35mm x 1.2 mm) or equivalent.

- b. The lower Side Impact Structural member must connect the bottom of the Main Hoop and the bottom of the Front Hoop. The lower frame rail/frame member may be this member if it meets the diameter and wall thickness requirements.
- c. The diagonal Side Impact Structural member must connect the upper and lower Side Impact Structural members forward of the Main Hoop and rearward of the Front Hoop.

T3.24.4 With proper triangulation, it is permissible to fabricate the Side Impact Structural members from more than one piece of tubing.

T3.25 Inspection Holes

T3.25.1 The Technical Inspectors may check the compliance of all tubes. This may be done by the use of ultra-sonic testing or by the drilling of inspection holes at the inspector's request.

T3.26 Composite Space Frames

Composite space frames are not prohibited by the rules, but any team wishing to build a composite space frame must seek approval from their organizing body. The team, at a minimum, must provide test data on the actual joints used in the frame. These tests must include static strength testing on representative configurations from all locations in the frame. An assessment of the ability of the joints to handle cyclic loading must also be assessed. This information must be included in the structural equivalency submission or the structural requirements certification submission, whichever approach the team is using.

NOTE: Given the extra complexity of a composite space frame and the detailed review process that will be required, teams are encouraged to submit their documents well in advance early of the deadline and to attain approval before starting their vehicle build.

T3.27 Monocoque General Requirements

T3.27.1 All equivalency calculations must prove equivalency relative to steel grade SAE/AISI 1010.

T3.27.2 All sections of the rules apply to monocoque structures except for the following sections which supplement or supersede other rule sections.

T3.27.3 Monocoque construction requires an approved Structural Equivalency Spreadsheet, per Section T3.9. The form must demonstrate that the design is equivalent to a welded frame in terms of energy dissipation, yield and ultimate strengths in bending, buckling and tension. Information must include: material type(s), cloth weights, resin type, fiber orientation, number of layers, core material, and lay-up technique. The 3-point bend test and shear test data and pictures must also be included as per T3.30 Monocoque Laminate Testing. The Structural Equivalency must address each of the items below. Data from the laminate testing results must be used as the basis for any strength or stiffness calculations.

T3.27.4 Quasi-isotropic layups are defined as having no more than two plies biased from an equal distribution in either the +/-45 or 0,90 directions.

T3.27.5 Composite and metallic monocoques have the same requirements.

T3.27.6 Composite monocoques must meet the materials requirements in Rule T3.8 Composite Materials.

T3.28 Monocoque Inspections

Due to the monocoque rules and methods of manufacture it is not always possible to inspect all aspect of a monocoque during technical inspection. For items which cannot be verified by an inspector it is the responsibility of the team to provide documentation, both visual and/or written, that the requirements have been met. Generally, the following items should be possible to be confirmed by the technical inspector:

- a. Verification of the main hoop outer diameter and thickness where it protrudes above the monocoque
- b. Visual verification that the main hoop goes to the lowest part of the tub, locally. This may be difficult as the tube is allowed to be integrated into the laminate but there is often a contour that comes from the tube that is visible.
- c. Verify mechanical attachment of main hoop to tub exists and matches the SES, at all points shown on the SES.
- d. Verify visually or by feel that the front roll hoop is installed. Verify mechanical attachment (if included) against the SES.

Items such as the size and composition of the front roll hoop, when integrally bonded to the monocoque, must be proven with documentation that shows dimensions on the tubes and pictures of the dimensioned tube being included in the layup. A team found to be improperly presenting any evidence of the manufacturing process will be barred from competing with a monocoque through at least the following year.

T3.29 Monocoque Buckling Modulus – Equivalent Flat Panel Calculation

When specified in the rules, the EI of the monocoque must be calculated as the EI of a flat panel with the same composition as the monocoque about the neutral axis of the laminate. The curvature of the panel and geometric cross section of the monocoque must be ignored for these calculations.

Calculations of EI that do not reference T3.29 may take into account the actual geometry of the monocoque.

T3.30 Monocoque Laminate Testing

T3.30.1 Side Impact Laminate - Teams must build a representative test panel with the same design, laminate, and fabrication method as used in the monocoque side impact zone (defined in T3.33) as a flat panel and perform a 3-point bending test on this panel. They must prove by physical testing that a panel measuring 275mm (10.8”) x 500 mm (19.7”) has at least the same properties as two baseline steel side impact tubes (See T3.4.1 “Baseline Steel Materials”) for buckling modulus, yield strength, ultimate strength and absorbed energy. The data from these tests and pictures of the test samples must be included in the SES, the test results will be used to derive strength, stiffness, and absorbed energy properties used in the SES formulae for side impact laminate panels. The test specimen must be presented at technical inspection. If the test specimen does not meet these requirements, then the monocoque side impact zone must be strengthened appropriately.

T3.30.2 Teams are required to make an equivalent test with two side impact baseline steel tubes (SAE/AISI 1010) such that any compliance in the test rig can be accounted for and to establish an absorbed energy value of the baseline tubes. Baseline tubes must be tested to a minimum displacement of 12.7mm (0.5 inch). The calculation of absorbed energy will use the integral of force times displacement from the initiation of load to 12.7mm (0.5 inch).

T3.30.3 Primary structure laminate other than side impact – Teams must build representative test panels for each ply schedule used in the regulated regions of the monocoque as a flat panel and perform a 3-point bending test on these panels. The test panels must measure 275mm (10.8”) x 500 mm (19.7”). The data from these tests and pictures of the test samples must be included in the SES, the test results

will be used to derive strength and stiffness properties used in the SES formula for all laminate panels. The test specimen must be presented at technical inspection.

- T3.30.4 The load applicator used to test any panel/tubes as required by T3.30.1, T3.30.2, or T3.30.3 must be metallic and have a radius of 50mm (2 inch).

The load applicator must overhang the test piece to prevent edge loading.

It is not acceptable to place any other material between the load applicator and the items on test.

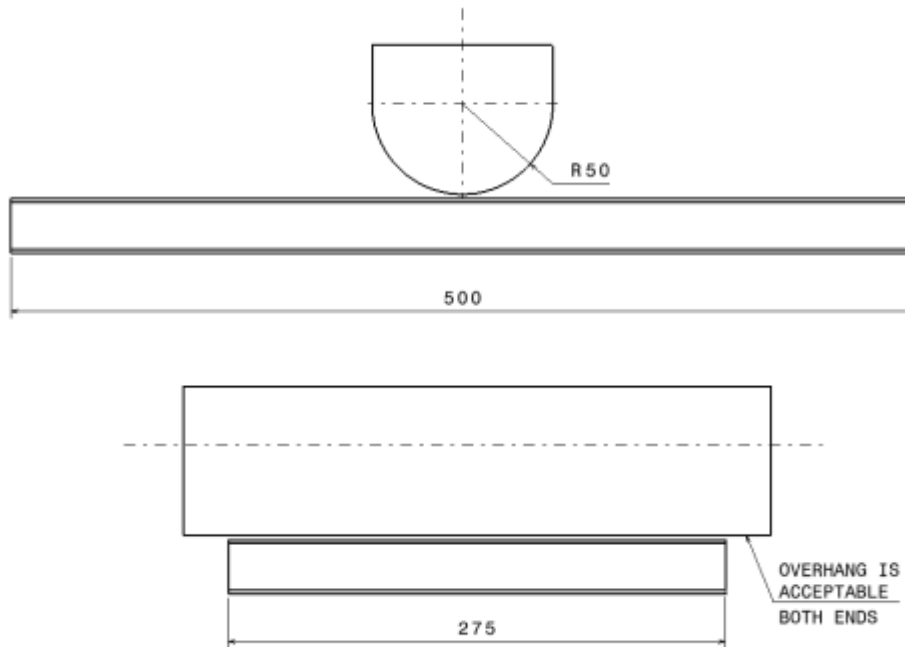

- T3.30.5 Perimeter shear tests must be completed by measuring the force required to push or pull a 25mm (1”) diameter flat punch through a flat laminate sample.

The sample, measuring at least 100mm x 100mm (3.9” x 3.9”), must have core and skin thicknesses identical to those used in the actual monocoque and be manufactured using the same materials and processes.

The fixture must support the entire sample, except for a 32mm (1.25”) hole aligned co-axially with the punch. The sample must not be clamped to the fixture.

The force-displacement data and photos of the test setup must be included in the SES.

The first peak in the load-deflection curve must be used to determine the skin shear strength; this may be less than the minimum force required by T3.32.3/T3.33.4.

The maximum force recorded must meet the requirements of T3.32.3/T3.33.4.

N: The edge of the punch and hole in the fixture may include an optional fillet up-to a maximum radius of 1mm (0.040”).

- T3.30.6 Laminate schedules that deviate from a quasi-isotropic layup must be tested in each orthogonal direction, i.e. two bending and shear test samples are required for each unique layup. All material properties in the weaker test direction must be at least 50% of those in the stronger test direction.

T3.31 Monocoque Front Bulkhead

See Rule T3.27 for general requirements that apply to all aspects of the monocoque. In addition, when modeled as an “L” shaped section the EI of the front bulkhead about both vertical and lateral axis must be equivalent to that of the tubes specified for the front bulkhead under T3.18. The length of the section perpendicular to the bulkhead may be a maximum of 25.4mm (1”) measured from the rearmost face of the bulkhead.

Furthermore, any front bulkhead which supports the IA plate must have a perimeter shear strength equivalent to a 1.5 mm thick steel plate.

T3.32 Monocoque Front Bulkhead Support

T3.32.1 In addition to proving that the strength of the monocoque is adequate, the monocoque must have equivalent EI to the sum of the EI of the six (6) baseline steel tubes that it replaces.

T3.32.2 The EI of the vertical side of the front bulkhead support structure must be equivalent to at least the EI of one baseline steel tube that it replaces when calculated as per rule T3.29 Monocoque Buckling Modulus.

T3.32.3 The perimeter shear strength of the monocoque laminate in the front bulkhead support structure should be at least 4kN (880 pounds) for a section with a diameter of 25 mm (1 inch). This must be proven by a physical test completed as per T3.30.2 and the results include in the SES

T3.33 Monocoque Side Impact

T3.33.1 In the region longitudinally forward of the Main Roll Hoop and aft of the Front Roll Hoop and vertically from 350 mm (13.8 inches) above the ground to the bottom surface of the floor of the monocoque must have a Buckling Modulus (E*I) equal to three (3) baseline steel tubes that it replaces.

T3.33.2 The vertical side impact zone between the upper surface of the floor and 350 mm (13.8 inches) above the ground must have a Buckling Modulus (E*I) equivalent to two baseline steel tubes and half the horizontal floor must have a Buckling Modulus (E*I) equivalent to one baseline steel tube per Rule T3.29 Monocoque Buckling Modulus.

T3.33.3 The vertical side impact zone between the upper surface of the floor and 350 mm (13.8 inches) above the ground must have an absorbed energy equivalent to two baseline steel tubes. Proof of equivalent absorbed energy is determined by physical testing per rule T3.30.2 and T3.30.3.

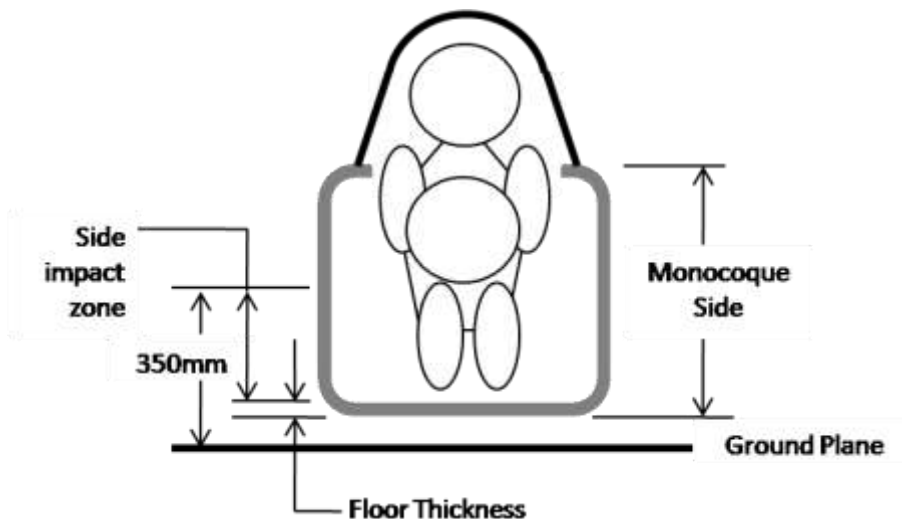

T3.33.4 The perimeter shear strength of the monocoque laminate should be at least 7.5 kN (1700 pounds) for a section with a diameter of 25mm (1 inch). This must be proven by physical test completed as per T3.30.2 and the results included in the SES.

T3.34 Monocoque Main Hoop

T3.34.1 The Main Hoop must be constructed of a single piece of uncut, continuous, closed section steel tubing per T3.4.1 and extend down to the bottom of the monocoque.

T3.34.2 The Main Hoop must be mechanically attached at the top and bottom of the monocoque and at intermediate locations as needed to show equivalency.

T3.34.3 Mounting plates welded to the Roll Hoop must be at least 2.0 mm (0.080 inch) thick steel.

T3.34.4 Attachment of the Main Hoop to the monocoque must comply with T3.39.

T3.35 Monocoque Front Hoop

T3.35.1 Composite materials are not allowed for the front hoop. See Rule T3.27 for general requirements that apply to all aspects of the monocoque.

T3.35.2 Attachment of the Front Hoop to the monocoque must comply with Rule T3.39.

T3.35.3 Fully laminating the front hoop into the monocoque is acceptable. Equivalence to at least four mounts compliant with Rule T3.40 must be shown in the SES.

Evidence as per T3.28 must be shown to pass technical inspection.

The use of adhesive as the sole method of attaching the front hoop to the monocoque is not acceptable. Fully laminating means encapsulating the hoop with an appropriate number and arrangement of plies.

T3.36 Monocoque Front and Main Hoop Bracing

T3.36.1 See Rule T3.27 for general requirements that apply to all aspects of the monocoque.

T3.36.2 Attachment of tubular Front or Main Hoop Bracing to the monocoque must comply with Rule T3.39.

T3.37 Monocoque Impact Attenuator Attachment

The attachment of the Impact Attenuator to a monocoque structure requires an approved “Structural Equivalency Spreadsheet” per Rule T3.9 that shows the equivalency to a minimum of eight (8) 8 mm Metric Grade 8.8 (5/16 inch SAE Grade 5) bolts.

T3.38 Monocoque Impact Attenuator Anti-Intrusion Plate

T3.38.1 Composite AI plates must not fail in a frontal impact. Strength of the AI plate must be verified by physical testing or a combination of physical testing and analysis. All physical test results and any analysis completed must be included in the SES.

T3.38.2 Strength of composite AI plates may be verified by physical testing under rules T3.21.2 and T3.21.3.

T3.38.3 Strength of composite AI plates may be verified by laminate material testing and calculations of 3-point bending and perimeter shear analysis. Composite laminate materials must be tested under T3.30.3 and T3.30.5. Analysis of the AI plate under 3-point bending must show the AI plate does not fail under a static load of 120 kN distributed over 150mm of length, and perimeter shear analysis must show each attachment can hold 20 kN in any direction.

T3.39 Monocoque Attachments

- T3.39.1 In any direction, each attachment point between the monocoque and the other primary structure must be able to carry a load of 30kN.
- T3.39.2 The laminate, brackets, backing plates and inserts must have sufficient stiffness, shear area, bearing area, weld area and strength to carry the specified 30kN load in any direction. Data obtained from the laminate perimeter shear strength test (T3.30.5) should be used to prove adequate shear area is provided.
- Proof that the brackets are adequately stiff must be documented in the SES. Hand calculations, or FEA with supporting hand calculations are both acceptable. The use of FEA alone is not acceptable.
- T3.39.3 Each attachment point requires a minimum of two (2) 8 mm Metric Grade 8.8 (5/16 inch SAE Grade 5) bolts
- T3.39.4 Each attachment point requires steel backing plates with a minimum thickness of 2 mm. Alternate materials may be used for backing plates if equivalency is approved.
- T3.39.5 The Front Hoop Bracing, Main Hoop Bracing and Main Hoop Bracing Supports only may use one (1) 10 mm Metric Grade 8.8 (3/8 inch SAE Grade 5) bolt as an alternative to T3.39.3 if the bolt is on the centerline of tube similar to the figure below.

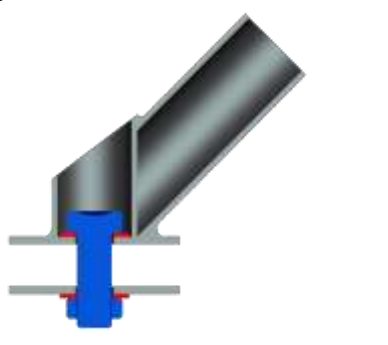

- T3.39.6 No crushing of the core is permitted
- T3.39.7 Main Hoop bracing attached to a monocoque (i.e. not welded to a rear space frame) is always considered “mechanically attached” and must comply with Rule T3.17.
- ### T3.40 Monocoque Driver’s Harness Attachment Points
- T3.40.1 The monocoque attachment points for the shoulder and lap belts must support a load of 13 kN (~3000 pounds) before failure.
- T3.40.2 The monocoque attachment points for the anti-submarine belts must support a load of 6.5 kN (~1500 pounds) before failure.
- T3.40.3 If the lap belts and anti-submarine belts are attached to the same attachment point, then this point must support a load of 19.5 kN (~4500 pounds) before failure.
- T3.40.4 The strength of lap belt, shoulder belt, and anti-submarine belt attachments must be proven by physical tests where the required load is applied to a representative attachment point where the proposed layup and attachment bracket are used.
- a. Edges of the test fixture supporting the sample must be a minimum of 125mm (5 inches) from the load application point (load vector intersecting a plane).

- b. Loads must be applied normal to the test sample.
- c. The width of the shoulder harness test sample must not be any wider than the shoulder harness "panel height" (see Structural Equivalency Spreadsheet) used to show equivalency for the shoulder harness mounting bar.
- d. Designs with attachments near a free edge may not support the free edge during the test.

NOTE: the rule is intended that the test specimen, to the best extent possible, represent the car as driven at competition. Teams are expected to test a panel in as close a configuration to what is built in the car as possible

ARTICLE 4: COCKPIT

T4.1 Cockpit Opening

T4.1.1 In order to ensure that the opening giving access to the cockpit is of adequate size, the template shown in Figure 8 will be inserted into the cockpit opening.

T4.1.2 The template will be held horizontally, parallel to the ground, and inserted vertically from a height above any Primary Structure or bodywork that is between the Front Hoop and the Main Hoop until it has passed below the top bar of the Side Impact Structure (or until it is 350 mm (13.8 inches) above the ground for monocoque cars). Fore and aft translation of the template is permitted during insertion.

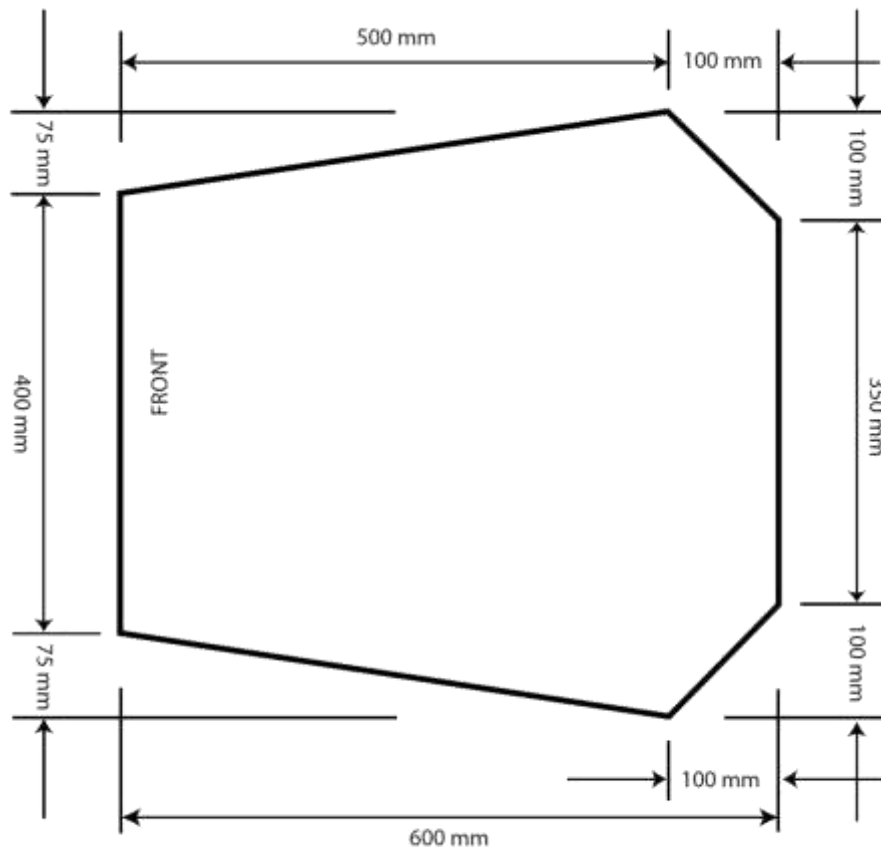

FIGURE 8

T4.1.3 During this test, the steering wheel, steering column, seat and all padding may be removed. The shifter or shift mechanism may not be removed unless it is integral with the steering wheel and is removed with the steering wheel. The firewall may not be moved or removed.

NOTE: As a practical matter, for the checks, the steering column will not be removed. The technical inspectors will maneuver the template around the steering column shaft, but not the steering column supports.

T4.2 Cockpit Internal Cross Section:

T4.2.1 A free vertical cross section, which allows the template shown in Figure 9 to be passed horizontally through the cockpit to a point 100 mm (4 inches) rearwards of the face of the rearmost pedal when in the inoperative position, must be maintained over its entire length. If the pedals are adjustable, they will be put in their most forward position.

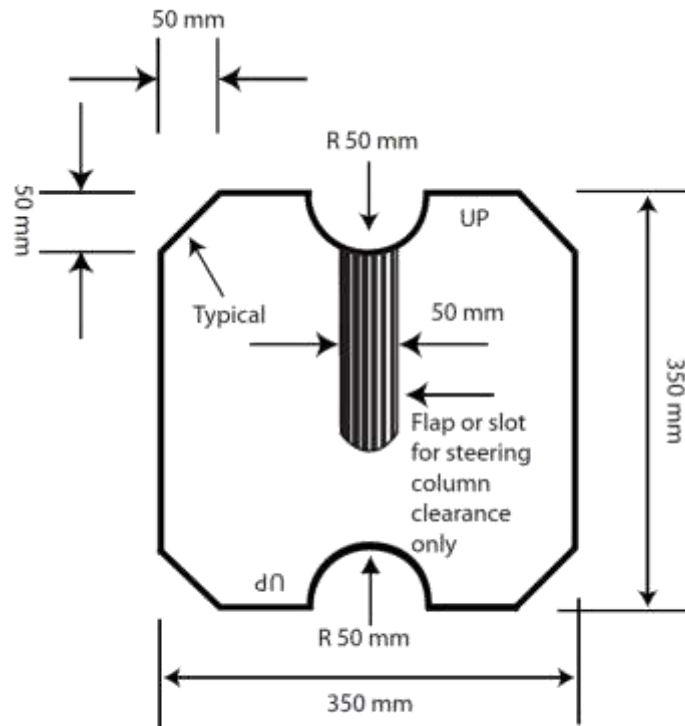

FIGURE 9

T4.2.2 The template, with maximum thickness of 7mm (0.275 inch), will be held vertically and inserted into the cockpit opening rearward of the rear-most portion of the steering column.

T4.2.3 The only items that may be removed for this test are the steering wheel, and any padding required by Rule T5.8 “Driver’s Leg Protection” that can be easily removed without the use of tools with the driver in the seat. The seat may NOT be removed.

T4.2.4 Cables, wires, hoses, tubes, etc. must not impede the passage of the templates required by T4.1.1 and T4.2.

T4.3 Driver’s Seat

T4.3.1 The lowest point of the driver’s seat must be no lower than the bottom surface of the lower frame rails or by having a longitudinal tube (or tubes) that meets the requirements for Side Impact tubing, passing underneath the lowest point of the seat.

- T4.3.2 When seated in the normal driving position, adequate heat insulation must be provided to ensure that the driver will not contact any metal or other materials which may become heated to a surface temperature above sixty degrees C (60°C). The insulation may be external to the cockpit or incorporated with the driver's seat or firewall. The design must show evidence of addressing all three (3) types of heat transfer, namely conduction, convection and radiation, with the following between the heat source, e.g. an exhaust pipe or coolant hose/tube and the panel that the driver could contact, e.g. the seat or floor:
- a. Conduction Isolation by:
 - i. No direct contact between the heat source and the panel, or
 - ii. A heat resistant, conduction isolation material with a minimum thickness of 8 mm (0.3 in) between the heat source and the panel.
 - b. Convection Isolation by a minimum air gap of 25 mm (1 inch) between the heat source and the panel
 - c. Radiation Isolation by:
 - i. A solid metal heat shield with a minimum thickness of 0.4 mm (0.015 in) or
 - ii. Reflective foil or tape when combined with T4.3.2.a.ii above.

T4.4 Floor Close-out

All vehicles must have a floor closeout made of one or more panels, which separate the driver from the pavement. If multiple panels are used, gaps between panels are not to exceed 3 mm (1/8 inch). The closeout must extend from the foot area to the firewall and prevent track debris from entering the car. The panels must be made of a solid, non-brittle material.

T4.5 Firewall

- T4.5.1 A firewall must separate the driver compartment from all components of the fuel supply, the engine oil, the liquid cooling systems and any high voltage system (PART EV - EV1.1). It must protect the neck of the tallest driver. It must extend sufficiently far upwards and/or rearwards such that any point less than 100 mm (4 ins.) above the bottom of the helmet of the tallest driver must not be in direct line of sight with any part of the fuel system, the cooling system or the engine oil system.
- T4.5.2 The firewall must be a non-permeable surface made from a rigid, fire resistant material.
- T4.5.3 Any firewall must seal completely against the passage of fluids, especially at the sides and the floor of the cockpit, i.e. there must be no holes in a firewall through which seat belts pass.
- T4.5.4 Pass-through for wiring, cables, etc. are allowable if grommets are used to seal the pass-through. Also, multiple panels may be used to form the firewall but must be sealed at the joints.

EV CARS ONLY

In addition, a firewall must separate the driver compartment from all tractive system components, including any HV wiring.

The tractive system firewall must be composed of two layers:

- a. One layer, facing the tractive system side, must be made of aluminum with a thickness between 0.5 and 0.7 mm. This part of the tractive system firewall must be grounded according to FSAE Rule PART EV - EV4.3.
- b. The second layer, facing the driver, must be made of an electrically insulating material. The material used for the second layer must meet UL94-V0, FAR25 or equivalent. The second layer must not be made of CFRP.
- c. The thickness of second layer must be sufficient to prevent penetrating this layer with a 4 mm wide screwdriver and 250N of force. The firewall must be rigidly mounted.

For tractive system firewalls, a sample of the firewall must be presented at technical inspection.

Conductive parts (except for the chassis) may not protrude through the firewall or must be properly insulated, see requirements above, on the driver side.

T4.6 Accessibility of Controls

All vehicle controls, including the shifter, must be operated from inside the cockpit without any part of the driver, e.g. hands, arms or elbows, being outside the planes of the Side Impact Structure defined in Rule T3.24 and T3.33.

T4.7 Driver Visibility

T4.7.1 General Requirement

The driver must have adequate visibility to the front and sides of the car. With the driver seated in a normal driving position he/she must have a minimum field of vision of two hundred degrees (200°) (a minimum one hundred degrees (100°) to either side of the driver). The required visibility may be obtained by the driver turning his/her head and/or the use of mirrors.

T4.7.2 Mirrors

If mirrors are required to meet Rule T4.7.1, they must remain in place and adjusted to enable the required visibility throughout all dynamic events.

T4.8 Driver Egress

All drivers must be able to exit to the side of the vehicle in no more than 5 seconds. Egress time begins with the driver in the fully seated position, hands in driving position on the connected steering wheel and wearing the required driver equipment. Egress time will stop when the driver has both feet on the pavement.

ARTICLE 5: DRIVERS EQUIPMENT (BELTS AND COCKPIT PADDING)

T5.1 Belts - General

T5.1.1 Definitions

- a. A 5-point system – consists of a 76 mm (3 inch) wide lap belt, approximately 76 mm (3 inch) wide shoulder straps and a single approximately 51 mm (2 inch) wide anti-submarine strap. The single anti-submarine strap must have a metal-to-metal connection with the single release common to the lap belt and shoulder harness.
- b. A 6-point system – consists of a 76 mm (3 inch) wide lap belt, approximately 76 mm (3 inch) wide shoulder straps and two (2) approximately 51 mm (2 inch) wide leg or anti-submarine straps.
- c. A 7-point system – system is the same as the 6-point except it has three (3) anti-submarine straps, two (2) from the 6-point system and one (1) from the 5-point system.
NOTE: 6 and 7-point harnesses to FIA specification 8853/98 and/or SFI Specification 16.5 with approximately 51 mm (2 inch) lap belts are acceptable.
- d. An “upright driving position” is defined as one with a seat back angled at thirty degrees (30°) or less from the vertical as measured along the line joining the two 200 mm circles of the template of the 95th percentile male as defined in Rule T3.10.3 and positioned per T3.10.4.
- e. A “reclined driving position” is defined as one with a seat back angled at more than thirty degrees (30°) from the vertical as measured along the line joining the two 200 mm circles of the template of the 95th percentile male as defined in Rule T3.10.3 and positioned per T3.10.4.
- f. The “chest-groin line” is the straight line that in side view follows the line of the shoulder belts from the chest to the release buckle.

T5.1.2 Harness Requirements

All drivers must use a 5, 6 or 7-point restraint harness meeting the following specifications:

- a. All driver restraint systems must meet SFI Specification 16.1, SFI Specification 16.5, or FIA specification 8853/98.
- b. The belts must bear the appropriate dated labels.
- c. The material of all straps must be in perfect condition.
- d. There must be a single release common to the lap belt and shoulder harness using a metal-to-metal quick release type latch.
- e. To accommodate drivers of differing builds, all lap belts must incorporate a tilt lock adjuster (“quick adjuster”). A tilt lock adjuster in each portion of the lap belt is highly recommended. Lap belts with “pull-up” adjusters are recommended over “pull-down” adjusters.
- f. Cars with a “reclined driving position” (see 5.1.1.e above) must have either a 6 point or 7-point harness, AND have either anti-submarine belts with tilt lock adjusters (“quick adjusters”) or have two (2) sets of anti-submarine belts installed.
- g. The shoulder harness must be the over-the-shoulder type. Only separate shoulder straps are permitted (i.e. “y”-type shoulder straps are not allowed). The “H”-type configuration is allowed.
- h. It is mandatory that the shoulder harness, where it passes over the shoulders, be 76 mm (3 inch) wide, except as noted below. The shoulder harness straps must be threaded through the three bar adjusters in accordance with manufacturer’s instructions.
- i. When the HANS device is used by the driver, FIA certified 51 mm (2 inch) wide shoulder harnesses are allowed. Should a driver, at any time not utilize the HANS device, then 76 mm (3 inch) wide shoulder harnesses are required.

T5.1.3 Harness Replacement

SFI spec harnesses must be replaced following December 31st of the 5th year after the date of manufacture as indicated by the label. FIA spec harnesses must be replaced following December 31st of the year marked on the label.

NOTE: FIA belts are normally certified for five (5) years from the date of manufacture.

T5.1.4 The restraint system must be worn tightly at all times.

T5.2 Belt, Strap and Harness Installation - General

T5.2.1 The lap belt, shoulder harness and anti-submarine strap(s) must be securely mounted to the Primary Structure. Such structure and any guide or support for the belts must meet the minimum requirements of T3.4.1.

NOTE: Rule T3.5.5 applies to these tubes as well so a non-straight shoulder harness bar would require support per T3.5.5

T5.2.2 The tab or bracket to which any harness is attached must have:

- a. A minimum cross sectional area of 60 sq. mm (0.093 sq. in) of steel to be sheared or failed in tension at any point of the tab, and
- b. A minimum thickness of 1.6 mm (0.063 inch).
- c. Where lap belts and anti-submarine belts use the same attachment point, a minimum cross sectional area of 90 sq. mm (0.140 sq. in) of steel to be sheared or failed in tension at any point of the tab.
- d. Where brackets are fastened to the chassis, two fasteners of 6mm Metric Grade 8.8 (1/4 inch SAE Grade 5) fasteners or stronger must be used.
- e. Where a single shear tab is welded to the chassis, the tab to tube welding must be on both sides of the base of the tab.

NOTE: Double shear attachments are preferred. Where possible, the tabs and brackets for double shear mounts should also be welded on both sides.

- T5.2.3 Harnesses, belts and straps must not pass through a firewall, i.e. all harness attachment points must be on the driver's side of any firewall.
- T5.2.4 The attachment of the Driver's Restraint System to a monocoque structure requires an approved Structural Equivalency Spreadsheet per Rule T3.9.
- T5.2.5 The restraint system installation is subject to approval of the Chief Technical Inspector.

T5.3 Lap Belt Mounting

- T5.3.1 The lap belts must pass around the pelvic area below the Anterior Superior Iliac Spines (the hip bones).
- T5.3.2 The lap belts must not be routed over the sides of the seat. The belts must come through the seat at the bottom of the sides of the seat to maximize the wrap of the pelvic surface and continue in a straight line to the anchorage point.
- T5.3.3 Where the belts or harness pass through a hole in the seat, the seat must be rolled or grommeted to prevent chafing of the belts.
- T5.3.4 To fit drivers of differing statures correctly, in side view, the lap belt must be capable of pivoting freely by using either a shouldered bolt or an eye bolt attachment. Mounting lap belts by wrapping them around frame tubes is not acceptable.
- T5.3.5 With an "upright driving position", in side view the lap belt must be at an angle of between forty-five degrees (45°) and sixty-five degrees (65°) to the horizontal. This means that the centerline of the lap belt at the seat bottom should be between 0 – 76 mm (0 – 3 inches) forward of the seat back to seat bottom junction. (See Figure 10)

FIGURE 10
Lap Belt Angle

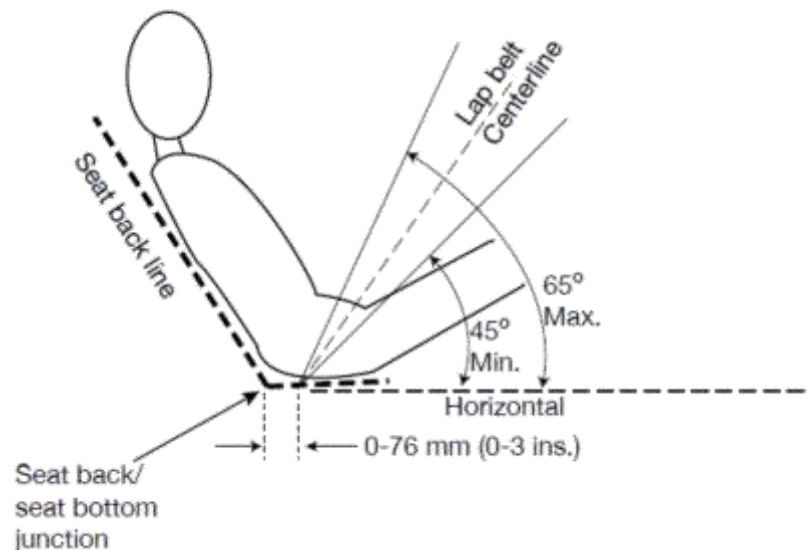

- T5.3.6 With a "reclined driving position", in side view the lap belt must be between an angle of sixty degrees (60°) and eighty degrees (80°) to the horizontal.

T5.3.7 Any bolt used to attach a lap belt, either directly to the chassis or to an intermediate bracket, must be a minimum of 10mm Metric Grade 8.8 (3/8 inch SAE Grade 5)

T5.4 Shoulder Harness

T5.4.1 The shoulder harness must be mounted behind the driver to a single piece of uncut, continuous, closed section steel tubing that meets the requirements of T3.4.1. This Shoulder Harness Mounting Bar must attach to the Main Hoop on both sides of the chassis. Bends in the Shoulder Harness Mounting Bar, if present, must be smooth and continuous with no evidence of crimping or wall failure.

Bent Shoulder Harness Mounting Bars are required to have bracing members attached at the bends and to the Main Hoop. Material for this bracing must meet the requirements of T3.4.1 “Shoulder Harness Mounting Bar Bracing.” The included angle in side view between the Shoulder Harness Bar and the braces must be no less than 30 degrees.

T5.4.2 The strength of any shoulder harness bar bracing tubes must be proved in the relevant tab of the team’s SES submission.

T5.4.3 The shoulder harness mounting points must be between 178 mm (7 inches) and 229 mm (9 inches) apart. (See Figure 11)

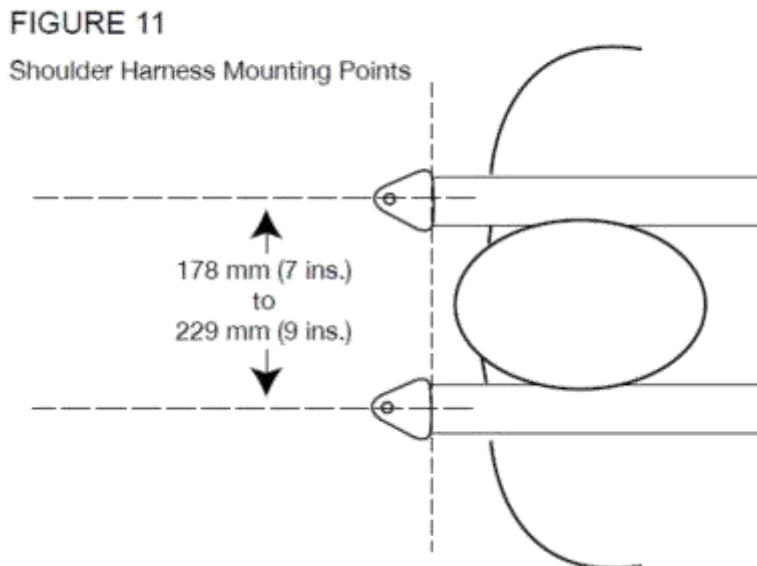

T5.4.4 From the driver’s shoulders rearwards to the mounting point or structural guide, the shoulder harness must be between ten degrees (10°) above the horizontal and twenty degrees (20°) below the horizontal. (See Figure 12).

T5.4.5 Any bolt used to attach a shoulder harness belt, either directly to the chassis or to an intermediate bracket, must be a minimum of 10mm Metric Grade 8.8 (3/8 inch SAE Grade 5)

FIGURE 12
Shoulder Harness Angle

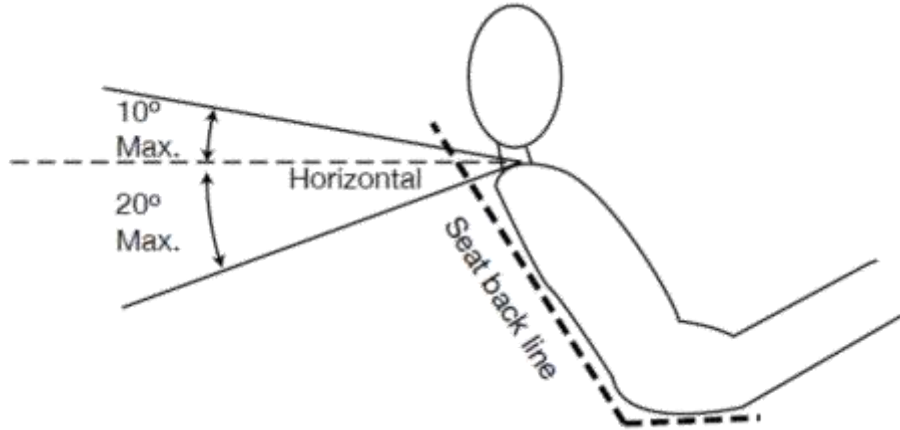

T5.5 Anti-Submarine Belt Mounting

T5.5.1 The anti-submarine belt of a 5-point harness must be mounted in line with, or angled slightly forward (up to twenty degrees (20°)) of, the driver's chest-groin line.

T5.5.2 The anti-submarine belts of a 6-point harness must be mounted either:

- a. With the belts going vertically down from the groin, or angled up to twenty degrees (20°) rearwards. The anchorage points should be approximately 100 mm (4 inches) apart. Or
- b. With the anchorage points on the Primary Structure at or near the lap belt anchorages, the driver sitting on the anti-submarine belts, and the belts coming up around the groin to the release buckle.

T5.5.3 Any bolt used to attach an anti-submarine belt, either directly to the chassis or to an intermediate bracket, must be a minimum of 8mm Metric Grade 8.8 (5/16 inch SAE Grade 5)

T5.6 Head Restraint

T5.6.1 A head restraint must be provided on the car to limit the rearward motion of the driver's head.

T5.6.2 The restraint must:

- a. Be vertical or near vertical in side view.
- b. Be padded with an energy absorbing material such as Ethafoam® or Ensolite® with a minimum thickness of 38 mm (1.5 inches).
- c. Have a minimum width of 15 cms (6 inches).
- d. Have a minimum area of 235 sq. cms (36 sq. inches) AND have a minimum height adjustment of 17.5 cms (7 inches), OR have a minimum height of 28 cms (11 inches).
- e. Be located so that for each driver:
 - i. The restraint is no more than 25 mm (1 inch) away from the back of the driver's helmet, with the driver in their normal driving position.
 - ii. The contact point of the back of the driver's helmet on the head restraint is no less than 50 mm (2 inch) from any edge of the head restraint.

NOTE 1: Head restraints may be changed to accommodate different drivers (See T1.2.2).

NOTE 2: Approximately 100mm (4”) longitudinal adjustment is required to accommodate 5th to 95th Percentile drivers. This is not a specific rules requirement, but teams must have sufficient longitudinal adjustment and/or alternative thickness head restraints available, such that the above requirements are met by all their drivers.

T5.6.3 Head restraint requirements must be met for all drivers.

T5.6.4 The restraint, its attachment and mounting must be strong enough to withstand a force of 890 Newtons (200 lbs. force) applied in a rearward direction.

T5.7 Roll Bar Padding

Any portion of the roll bar, roll bar bracing or frame which might be contacted by the driver’s helmet must be covered with a minimum thickness of 12 mm (0.5 inch) of padding which meets SFI spec 45.1 or FIA 8857-2001.

T5.8 Driver’s Leg Protection

T5.8.1 To keep the driver’s legs away from moving or sharp components, all moving suspension and steering components, and other sharp edges inside the cockpit between the front roll hoop and a vertical plane 100 mm (4 inches) rearward of the pedals, must be shielded with a shield made of a solid material. Moving components include, but are not limited to springs, shock absorbers, rocker arms, anti-roll/sway bars, steering racks and steering column CV joints.

T5.8.2 Covers over suspension and steering components must be removable to allow inspection of the mounting points.

ARTICLE 6: GENERAL CHASSIS RULES

T6.1 Suspension

T6.1.1 The car must be equipped with a fully operational suspension system with shock absorbers, front and rear, with usable wheel travel of at least 50.8 mm (2 inches), 25.4 mm (1 inch) jounce and 25.4 mm (1 inch) rebound, with driver seated. The judges reserve the right to disqualify cars which do not represent a serious attempt at an operational suspension system or which demonstrate handling inappropriate for an autocross circuit.

T6.1.2 All suspension mounting points must be visible at Technical Inspection, either by direct view or by removing any covers.

T6.2 Ground Clearance

Ground clearance must be sufficient to prevent any portion of the car, other than the tires, from touching the ground during track events. Intentional or excessive ground contact of any portion of the car other than the tires will forfeit a run or an entire dynamic event.

Comment: The intention of this rule is that sliding skirts or other devices that by design, fabrication or as a consequence of moving, contact the track surface are prohibited and any unintended contact with the ground which either causes damage, or in the opinion of the ‘dynamic event organizers’ could result in damage to the track, will result in forfeit of a run or an entire dynamic event

T6.3 Wheels

T6.3.1 The wheels of the car must be 203.2 mm (8.0 inches) or more in diameter.

T6.3.2 Any wheel mounting system that uses a single retaining nut must incorporate a device to retain the nut and the wheel in the event that the nut loosens. A second nut (“jam nut”) does not meet these requirements.

T6.3.3 Standard wheel lug bolts are considered engineering fasteners and any modification will be subject to extra scrutiny during technical inspection. Teams using modified lug bolts or custom designs will be required to provide proof that good engineering practices have been followed in their design.

T6.3.4 Aluminum wheel nuts may be used, but they must be hard anodized and in pristine condition.

T6.4 Tires

T6.4.1 Vehicles may have two types of tires as follows:

- a. Dry Tires – The tires on the vehicle when it is presented for technical inspection are defined as its “Dry Tires”. The dry tires may be any size or type. They may be slicks or treaded.
- b. Rain Tires – Rain tires may be any size or type of treaded or grooved tire provided:
 - i. The tread pattern or grooves were molded in by the tire manufacturer, or were cut by the tire manufacturer or his appointed agent. Any grooves that have been cut must have documentary proof that it was done in accordance with these rules.
 - ii. There is a minimum tread depth of 2.4 mms (3/32 inch).

Hand cutting, grooving or modification of the tires by the teams is specifically prohibited.

T6.4.2 Within each tire set, the tire compound or size, or wheel type or size may not be changed after static judging has begun. Tire warmers are not allowed. No traction enhancers may be applied to the tires after the static judging has begun, or at any time on-site at the competition.

NOTE: Due to the hazardous nature (significant health effects) of some traction modifier ingredients, teams are advised to closely follow manufacturers recommended procedures for safely handling and use of traction modifiers, if used before competition.

T6.5 Steering

T6.5.1 The steering wheel must be mechanically connected to the front wheels, i.e. “steer-by-wire” or electrically actuated steering of the front wheels, is prohibited.

T6.5.2 The steering system must have positive steering stops that prevent the steering linkages from locking up (the inversion of a four-bar linkage at one of the pivots). The stops may be placed on the uprights or on the rack and must prevent the tires from contacting suspension, body, or frame members during the track events.

T6.5.3 Allowable steering system free play is limited to seven degrees (7°) total measured at the steering wheel.

T6.5.4 The steering wheel must be attached to the column with a quick disconnect. The driver must be able to operate the quick disconnect while in the normal driving position with gloves on.

T6.5.5 Rear wheel steering, which may be electrically actuated, is permitted but only if mechanical stops limit the range of angular movement of the rear wheels to a maximum of six degrees (6°). This must be demonstrated with a driver in the car and the team must provide the facility for the steering angle range to be verified at Technical Inspection.

T6.5.6 The steering wheel must have a continuous perimeter that is near circular or near oval, i.e. the outer perimeter profile may have some straight sections, but no concave sections. “H”, “Figure 8”, or cutout wheels are not allowed.

T6.5.7 In any angular position, the top of the steering wheel must be no higher than the top-most surface of the Front Hoop. See Figure 3.

- T6.5.8 Steering systems using cables for actuation are not prohibited by T6.5.1 but additional documentation must be submitted. The team must submit a failure modes and effects analysis report with design details of the proposed system as part of the structural equivalency spreadsheet (SES) or structural requirements certification form (SRCF). The report must outline the analysis that was done to show the steering system will function properly, potential failure modes and the effects of each failure mode and finally failure mitigation strategies used by the team. The organizing committee will review the submission and advise the team if the design is approved. If not approved, a non-cable based steering system must be used instead.
- T6.5.9 The steering rack must be mechanically attached to the frame; if fasteners are used they must be compliant with Rule T11.2.
- T6.5.10 Joints between all components attaching the steering wheel to the steering rack must be mechanical and be visible at Tech Inspection. Bonded joints without a mechanical backup are not permitted.

T6.6 Jacking Point

- T6.6.1 A jacking point, which is capable of supporting the car's weight and of engaging the organizers' "quick jacks", must be provided at the rear of the car.
- T6.6.2 The jacking point is required to be:
- Visible to a person standing 1 meter (3 feet) behind the car.
 - Painted orange.
 - Oriented horizontally and perpendicular to the centerline of the car
 - Made from round, 25 – 29 mm (1 – 1 1/8 inch) O.D. aluminum or steel tube
 - A minimum of 300 mm (12 inches) long
 - Exposed around the lower 180 degrees (180°) of its circumference over a minimum length of 280 mm (11 in)
 - The height of the tube is required to be such that:
 - There is a minimum of 75 mm (3 in) clearance from the bottom of the tube to the ground measured at tech inspection.
 - With the bottom of the tube 200 mm (7.9 in) above ground, the wheels do not touch the ground when they are in full rebound.
 - Access from the rear of the tube must be unobstructed for at least 300mm of its length

Comment on Disabled Cars – The organizers and the Rules Committee remind teams that cars disabled on course must be removed as quickly as possible. A variety of tools may be used to move disabled cars including quick jacks, dollies of different types, tow ropes and occasionally even boards. We expect cars to be strong enough to be easily moved without damage. Speed is important in clearing the course and although the course crew exercises due care, parts of a vehicle can be damaged during removal. The organizers are not responsible for damage that occurs when moving disabled vehicles. Removal/recovery workers will jack, lift, carry or tow the car at whatever points they find easiest to access. Accordingly, we advise teams to consider the strength and location of all obvious jacking, lifting and towing points during the design process.

T6.7 Rollover Stability

- T6.7.1 The track and center of gravity of the car must combine to provide adequate rollover stability.
- T6.7.2 Rollover stability will be evaluated on a tilt table using a pass/fail test. The vehicle must not roll when tilted at an angle of sixty degrees (60°) to the horizontal in either direction, corresponding to 1.7 G's. The tilt test will be conducted with the tallest driver in the normal driving position.

ARTICLE 7: BRAKE SYSTEM

T7.1 Brake System - General

The car must be equipped with a braking system that acts on all four wheels and is operated by a single control.

- T7.1.1 It must have two (2) independent hydraulic circuits such that in the case of a leak or failure at any point in the system, effective braking power is maintained on at least two (2) wheels. Each hydraulic circuit must have its own fluid reserve, either by the use of separate reservoirs or by the use of a dammed, OEM-style reservoir.
- T7.1.2 A single brake acting on a limited-slip differential is acceptable.
- T7.1.3 The brake system must be capable of locking all four (4) wheels during the test specified below.
- T7.1.4 “Brake-by-wire” systems are prohibited.
- T7.1.5 Unarmored plastic brake lines are prohibited.
- T7.1.6 The braking systems must be protected with scatter shields from failure of the drive train (see T8.4) or from minor collisions.
- T7.1.7 In side view no portion of the brake system that is mounted on the sprung part of the car must project below the lower surface of the frame or the monocoque, whichever is applicable.
- T7.1.8 The brake pedal must be designed to withstand a force of 2000 N without any failure of the brake system or pedal box. This may be tested by pressing the pedal with the maximum force that can be exerted by any official when seated normally.
- T7.1.9 The brake pedal must be fabricated from steel or aluminum or machined from steel, aluminum or titanium.
- T7.1.10 EV ONLY: The first 90% of the brake pedal travel may be used to regenerate brake energy without actuating the hydraulic brake system. The remaining brake pedal travel must directly actuate the hydraulic brake system, but brake energy regeneration may remain active. Any strategy to regenerate energy whilst coasting or whilst braking must be covered by the FMEA

T7.2 Brake Test

- T7.2.1 The brake system will be dynamically tested and must demonstrate the capability of locking all four (4) wheels and stopping the vehicle in a straight line at the end of an acceleration run specified by the brake inspectors.
- T7.2.2 **EV ONLY:** After accelerating the tractive system has to be switched off by the driver and the driver has to lock all four wheels of the vehicle by braking. The brake test is passed if all four wheels lock while the tractive system is shut down.

NOTE: It is acceptable for the Tractive System Active Light to switch off shortly after the vehicle has come to a complete stop as the reduction of the system voltage may take up to 5 seconds.

T7.3 Brake Over-Travel Switch

- T7.3.1 A brake pedal over-travel switch must be installed on the car as part of the shutdown system and wired in series with the shutdown buttons. This switch must be installed so that in the event of brake

system failure such that the brake pedal over travels it will result in the shutdown system being activated and controlling the systems as defined in Part IC Article 4 (IC vehicles) or EV5.4 (electric vehicles).

- T7.3.2 Repeated actuation of the switch must not restore power to these components, and it must be designed so that the driver cannot reset it.
- T7.3.3 The switch must be implemented with analog components, and not through recourse to programmable logic controllers, engine control units, or similar functioning digital controllers.
- T7.3.4 The Brake Over-Travel switch must be a mechanical single pole, single throw (commonly known as a two-position) switch (push-pull or flip type) as shown below.



T7.4 Brake Light

- T7.4.1 The car must be equipped with a red brake light. The brake light itself has to have a black background and a rectangular, triangular or near round shape with a minimum shining surface of at least 15cm². The brake light must be clearly visible from the rear in very bright sunlight. When LED lights are used without a diffuser, they may not be more than 20mm apart. If a single line of LEDs is used, the minimum length is 150mm.
- T7.4.2 This light must be mounted between the wheel centerline and driver’s shoulder level vertically and approximately on vehicle centerline laterally.

ARTICLE 8: POWERTRAIN

T8.1 Coolant Fluid Limitations

Water-cooled engines must only use plain water. Electric motors, accumulators or HV electronics may use plain water or oil as the coolant. Glycol-based antifreeze, “water wetter”, water pump lubricants of any kind, or any other additives are strictly prohibited.

T8.2 System Sealing

- T8.2.1 Any cooling or lubrication system must be sealed to prevent leakage.
- T8.2.2 Separate catch cans must be employed to retain fluids from any vents for the engine coolant system or engine lubrication system. Each catch-can must have a minimum volume of ten (10) percent of the fluid being contained or 0.9 liter (one U.S. quart) whichever is greater. Motorcycle engine/gearbox combinations must comply with T8.2.2.

- T8.2.3 Any vent on other systems containing liquid lubricant or coolant, i.e., a differential, gearbox, or electric motor must have a catch-can with a minimum volume of ten (10) percent of the fluid being contained or 0.5 liter (half U.S. quart), whichever is greater.
- T8.2.4 Catch cans must be capable of containing boiling water without deformation, and be located rearwards of the firewall below the driver's shoulder level, and be positively retained, i.e. no tie-wraps or tape.
- T8.2.5 Any catch can on the cooling system must vent through a hose with a minimum internal diameter of 3 mm (1/8 inch) down to the bottom levels of the Frame.

T8.3 Transmission and Drive

Any transmission and drivetrain may be used.

T8.4 Drive Train Shields and Guards

- T8.4.1 Exposed high-speed final drivetrain equipment such as Continuously Variable Transmissions (CVTs), sprockets, gears, pulleys, torque converters, clutches, belt drives, clutch drives and electric motors, must be fitted with scatter shields in case of failure. The final drivetrain shield must cover the chain or belt from the drive sprocket to the driven sprocket/chain wheel/belt or pulley. The final drivetrain shield must start and end parallel to the lowest point of the chain wheel/belt/pulley. (See figure below) Body panels or other existing covers are not acceptable unless constructed from approved materials per T8.4.3 or T8.4.4.

NOTE: If equipped, the engine drive sprocket cover may be used as part of the scatter shield system.

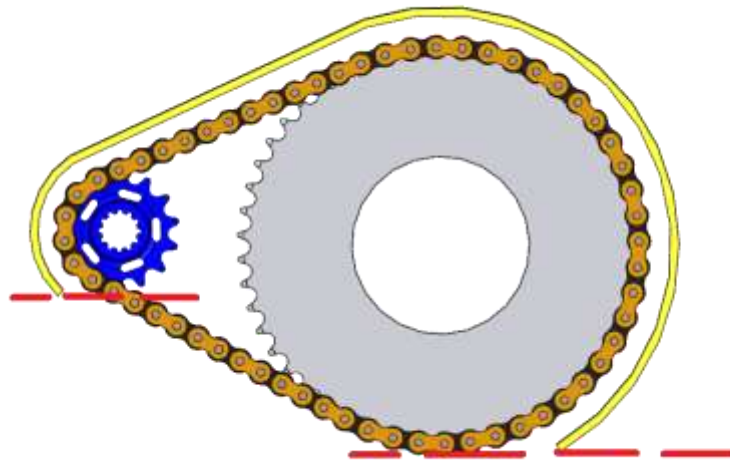

Comment: Scatter shields are intended to contain drivetrain parts which might separate from the car.

- T8.4.2 Perforated material may not be used for the construction of scatter shields.
- T8.4.3 Chain Drive - Scatter shields for chains must be made of at least 2.66 mm (0.105 inch) steel (no alternatives are allowed), and have a minimum width equal to three (3) times the width of the chain. The guard must be centered on the center line of the chain and remain aligned with the chain under all conditions.
- T8.4.4 Non-metallic Belt Drive - Scatter shields for belts must be made from at least 3.0 mm (0.120 inch) Aluminum Alloy 6061-T6, and have a minimum width that is equal to 1.7 times the width of the belt.

The guard must be centered on the center line of the belt and remain aligned with the belt under all conditions.

- T8.4.5 Attachment Fasteners - All fasteners attaching scatter shields and guards must be a minimum 6mm Metric Grade 8.8 (1/4 inch SAE Grade 5) or stronger.
- T8.4.6 Finger Guards – Finger guards are required to cover any drivetrain parts that spin while the car is stationary with the engine running. Finger guards may be made of lighter material, sufficient to resist finger forces. Mesh or perforated material may be used but must prevent the passage of a 12 mm (1/2 inch) diameter object through the guard.

Comment: Finger guards are intended to prevent finger intrusion into rotating equipment while the vehicle is at rest.

T8.5 Integrity of systems carrying fluids – Tilt Test

- T8.5.1 During technical inspection, the car must be capable of being tilted to a forty-five-degree (45°) angle without leaking fluid of any type.
- T8.5.2 The tilt test will be conducted with the vehicle containing the maximum amount of fluids it will carry during any test or event.

ARTICLE 9: AERODYNAMIC DEVICES

T9.1 Aero Dynamics and Ground Effects - General

All aerodynamic devices must satisfy the following requirements which must be met in conjunction with the Vehicle Configuration requirements defined in T2.1.

The keep out zones shown in the illustrations below clarify the intention of the written requirements.

T9.2 Location – Front Mounted Devices

- T9.2.1 In plan view, any part of any aerodynamic device, wing, under tray, splitter or end plate must not be:
- Further forward than 700 mm (27.6 inches) forward of the fronts of the front tires
 - Wider than the outside of the front tires measured at the height of the hubs.
- T9.2.2 When viewed from the front of the vehicle, the part of the front wheels/tires that are more than 250 mm (9.8 inches) above ground level must be unobstructed.

NOTE: 9.2.1 and 9.2.2 apply with the wheels in the straight ahead position

T9.3 Location Rear Mounted Devices:

- T9.3.1 In plan view, any part of any aerodynamic device, wing, undertray or splitter must not be:
- Further rearward than 250 mm (9.8 inches) rearward of the rear of the rear tires
 - Further forward than a vertical plane through the rearmost portion of the front face of the driver head restraint support, excluding any padding, set (if adjustable) in its fully rearward position (excluding undertrays).
 - Wider than the inside of the rear tires, measured at the height of the hub centerline.
- T9.3.2 In side elevation, no part of the rear wing or aerodynamic device (including end-plates) must be higher than 1.2 meters above the ground when measured without a driver in the vehicle

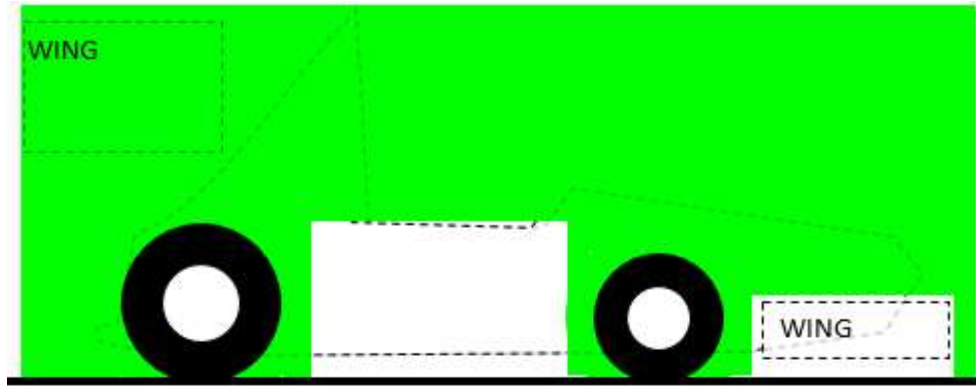

T9.4 Location – General

T9.4.1 Between the centerlines of the front and rear wheel axles, an aerodynamic device (e.g. undertray) may extend outboard in plan view to a line drawn connecting the outer surfaces of the front and rear tires at the height of the wheel centers

T9.4.2 Except as permitted under T9.3.1, any aerodynamic devices, or other bodywork, located between the transverse vertical planes positioned at the front and rear axle centerlines must not exceed a height of 500 mm (19.7 inches) above the ground when measured without a driver in the vehicle. (Bodywork within vertical fore and aft planes set at 400 mm (15.75 inches) outboard from the centerline on each side of the vehicle is excluded from this requirement).

The Keep out zones of T2.1 (3) must not be infringed.

T9.5 Minimum Radii of Edges of Aerodynamic Devices

T9.5.1 All forward facing wing edges including wings, end plates, Gurney flaps, wicker bills and undertrays that could contact a pedestrian must have a minimum radius of 5 mm (0.2 inches) for all horizontal edges and 3mm (0.12 inches) for vertical edges (end plates). These radius requirements must be achieved with permanently affixed components and with specific design intent to meet this radius requirement.

For example, pushed on pieces of split tube relying on friction for retention are not a satisfactory engineering method of achieving the radii.

T9.6 Ground Effect Devices

No power device may be used to move or remove air from under the vehicle except fans designed exclusively for cooling. Power ground effects are prohibited.

T9.7 Aerodynamic Devices Stability and Strength

T9.7.1 All aerodynamic devices must be designed such that the mounting system provides adequate rigidity in the static condition and such that the aerodynamic devices do not oscillate or move excessively when the vehicle is moving. In Technical Inspection this will be checked by pushing on the aerodynamic devices in any direction and at any point.

NOTE: The following is guidance as to how this rule will be applied but actual conformance will be up to technical inspectors at the respective competitions. The intent is to reduce the likelihood of wings detaching from cars.

1. If any deflection is significant, then a force of approximately 200N may be applied and the resulting deflection should not be more than 25mm and any permanent deflection less than 5mm.
2. If any vehicle on track is observed to have large, uncontrolled movements of aerodynamic devices, then officials may Black Flag the car for inspection and the car may be excluded from that run and until any issue identified is rectified.

ARTICLE 10: COMPRESSED GAS SYSTEMS AND HIGH PRESSURE HYDRAULICS

T10.1 Compressed Gas Cylinders and Lines

Any system on the vehicle that uses a compressed gas as an actuating medium must comply with the following requirements:

- a. Working Gas-The working gas must be nonflammable, e.g. air, nitrogen, carbon dioxide.
- b. Cylinder Certification- The gas cylinder/tank must be of proprietary manufacture, designed and built for the pressure being used, certified by an accredited testing laboratory in the country of its origin, and labeled or stamped appropriately.
- c. Pressure Regulation-The pressure regulator must be mounted directly onto the gas cylinder/tank.
- d. Protection – The gas cylinder/tank and lines must be protected from rollover, collision from any direction, or damage resulting from the failure of rotating equipment.
- e. Cylinder Location- The gas cylinder/tank and the pressure regulator must be located either rearward of the Main Roll Hoop and within the envelope defined by the Main Roll Hoop and the Frame (see T3.3), or in a structural side-pod. In either case it must be protected by structure that meets the requirements of T3.24 or T3.33. It must not be located in the cockpit.
- f. Cylinder Mounting- The gas cylinder/tank must be securely mounted to the Frame, engine or transmission.
- g. Cylinder Axis- The axis of the gas cylinder/tank must not point at the driver.

- h. Insulation- The gas cylinder/tank must be insulated from any heat sources, e.g. the exhaust system.
- i. Lines and Fittings- The gas lines and fittings must be appropriate for the maximum possible operating pressure of the system.

T10.2 High Pressure Hydraulic Pumps and Lines

The driver and anyone standing outside the car must be shielded from any hydraulic pumps and lines with line pressures of 2100 kPa (300 psi) or higher. The shields must be steel or aluminum with a minimum thickness of 1 mm (0.039 inch).

Brake lines are not classified as “hydraulic pump lines” and are excluded from T10.2.

ARTICLE 11: FASTENERS

T11.1 Fastener Grade Requirements

T11.1.1 All threaded fasteners utilized in the driver’s cell structure, and the steering, braking, driver’s harness and suspension systems must meet or exceed SAE Grade 5, Metric Grade 8.8 and/or AN/MS specifications.

T11.1.2 The use of button head cap, countersunk head, pan head, flat head or round head screws or bolts is prohibited in ANY location in the following systems. Hexagonal recessed drive screws or bolts (sometimes called Socket head cap screws or Allen screws/bolts) are permitted:

- a) Primary Structure attachments
- b) Impact attenuator attachment
- c) Driver’s harness attachment
- d) Steering system
- e) Brake system
- f) Suspension system

T11.1.3 Any bolted joint in the primary structure using either tabs or brackets, must have an edge distance ratio “e/D” of 1.5 or greater. “D” equals the hole diameter. “e” equals the distance from the edge of the hole to the nearest free edge.

Tabs attaching suspension members to the primary structure are not required to meet this rule

T11.2 Securing Fasteners

T11.2.1 All critical bolt, nuts, and other fasteners on the steering, braking, driver’s harness, and suspension must be secured from unintentional loosening by the use of positive locking mechanisms. Positive locking mechanisms are defined as those that:

- a. The Technical Inspectors (and the team members) are able to see that the device/system is in place, i.e. it is visible.
- b. The “positive locking mechanism” does not rely on the clamping force to apply the “locking” or anti-vibration feature. In other words, if it loosens a bit, it still prevents the nut or bolt coming completely loose.

Positive locking mechanisms include:

- a. Correctly installed safety wiring
- b. Cotter pins
- c. Nylon lock nuts (Except in high temperature locations where nylon could fail approximately 80 degrees Celsius or above)
- d. Prevailing torque lock nuts

Lock washers, bolts with nylon patches and thread locking compounds, e.g. Loctite®, DO NOT meet the positive locking requirement.

T11.2.2 There must be a minimum of two (2) full threads projecting from any lock nut.

T11.2.3 All spherical rod ends and spherical bearings on the steering or suspension must be in double shear or captured by having a screw/bolt head or washer with an O.D. that is larger than spherical bearing housing I.D.

T11.2.4 Adjustable tie-rod ends must be constrained with a jam nut to prevent loosening.

ARTICLE 12: TRANSPONDERS

T12.1 Transponders – North American FSAE Competitions

T12.1.1 Transponders will be used as part of the timing system for the dynamic events at the North American FSAE competitions

T12.1.2 Each team is responsible for having a functional, properly mounted transponder of the specified type on their vehicle. Vehicles without a specified transponder will not be allowed to compete in any event for which a transponder is used for timing and scoring.

T12.1.3 The approved transponder type(s) will be provided on the competition website.

T12.1.4 For Electric Vehicles, it is the responsibility of the team to ensure that electrical interference from their vehicle does not stop the transponder from functioning correctly

T12.2 Transponders – Events outside North America

Transponders may be used for timing and scoring at competitions outside North America and may be provided by the competition organizers. The transponders for the North American FSAE competitions may or may not be compatible with the systems used for other events. Teams should check the individual competition websites for further details.

T12.3 Transponder Mounting – All Events

The transponder mounting requirements are:

- a. Orientation – The transponder must be mounted vertically and orientated so the number can be read “right-side up”.
- b. Location – The transponder must be mounted on the driver’s right side of the car forward of the front roll hoop. The transponder must be no more than 60 cm (24 in) above the track.
- c. Obstructions – There must be an open, unobstructed line between the antenna on the bottom of the transponder and the ground. Metal and carbon fiber may interrupt the transponder signal. The signal will normally transmit through fiberglass and plastic. If the signal will be obstructed by metal or carbon fiber, a 10.2 cm (4 in) diameter opening may be cut, the transponder mounted flush with the opening, and the opening covered with a material transparent to the signal.
- d. Protection – Mount the transponder where it will be protected from obstacles.

ARTICLE 13: VEHICLE IDENTIFICATION

T13.1 Car Number

T13.1.1 Each car will be assigned a number at the time of its entry into a competition.

T13.1.2 Car numbers must appear on the vehicle as follows:

Locations: In three (3) locations: the **front** and both **sides**;

- a. Height: At least 152.4 mm (6 inch) high;
- b. Font: Block numbers (i.e. sans-serif characters). Italic, outline, serif, shadow, or cursive numbers are prohibited.
- c. Stroke Width and Spacing between Numbers: At least 18 mm (3/4 inch).
- d. Color: Either white numbers on a black background or black numbers on a white background. No other color combinations will be approved.
- e. Background shape: The number background must be one of the following: round, oval, square or rectangular. There must be at least 25.4 mm (1 inch) between the edge of the numbers and the edge of the background.
- f. Clear: The numbers must not be obscured by parts of the car, e.g. wheels, side pods, exhaust system, etc.

Comment: Car numbers must be quickly read by course marshals when your car is moving at speed. Make your numbers easy to see and easy to read.

Example:



T13.1.3 Electric Vehicles - Car numbers of vehicles registered for Formula SAE Electric must be preceded by a capital letter “E” in the same size and font as the numerals. Example: E219

T13.2 School Name

T13.2.1 Each car must clearly display the school name (or initials – if unique and generally recognized) in roman characters at least 50 mm (2 inch) high on both sides of the vehicle. The characters must be placed on a high contrast background in an easily visible location.

T13.2.2 The school name may also appear in non-roman characters, but the roman character version must be uppermost on the sides.

T13.3 SAE Logo

The SAE logo must be displayed on the front and/or both sides of the vehicle in a prominent location. SAE logo stickers will be provided to the teams on site.

T13.4 Technical Inspection Sticker Space

T13.4.1 Technical inspection stickers will be placed on the upper nose of the vehicle. Cars must have a clear and unobstructed area at least 25.4 cm wide x 20.3 cm high (10” x 8”) on the upper front surface of the nose along the vehicle centerline.

T13.4.2 Vehicles that are being entered into multiple competitions in the FSAE series must allow sufficient space along the nose centerline for all inspection stickers.

ARTICLE 14: EQUIPMENT REQUIREMENTS

T14.1 Driver’s Equipment

The equipment specified below must be worn by the driver anytime he or she is in the cockpit with the engine running or with the tractive system active for electric vehicles and anytime between starting a dynamic event and either finishing or abandoning a dynamic event. Removal of any driver equipment during the event will result in disqualification.

T14.2 Helmet

A well-fitting, closed face helmet that meets one of the following certifications and is labeled as such:

- Snell K2005, K2010, K2015, M2005, M2010, M2015, SA2005, SA2010, SAH2010, SA2015
- SFI 31.2/2005, 31.2/2010, 31.2/2015, 41.2/2005, 41.2/2010, 41.2/2015
- FIA 8860-2004, FIA 8860-2010, FIA 8859-2015
- British Standards Institution BS 6658-85 Type A/FR rating (Types A and B are not accepted)

Open faced helmets and off-road helmets (helmets without integrated eye shields) are not approved.

All helmets to be used in the competition must be presented during Technical Inspection where approved helmets will be stickered. The organizer reserves the right to impound all non-approved helmets until the end of the competition.

T14.3 Balaclava

A balaclava which covers the driver’s head, hair and neck, made from acceptable fire resistant material as defined in T14.12, or a full helmet skirt of acceptable fire resistant material. The balaclava requirement applies to drivers of either gender, with any hair length.

T14.4 Eye Protection

Impact resistant helmet face shield, made from approved impact resistant materials. The face shield supplied with approved helmets (See T14.2 above) meets this requirement.

T14.5 Suit

A fire resistant one-piece suit, made from a minimum of two (2) layers that covers the body from the neck down to the ankles and the wrists. The suit must be certified to one of the following standards and be labeled as such:

- SFI 3-2A/5 (or higher)



- FIA Standard 1986



- FIA Standard 8856-2000

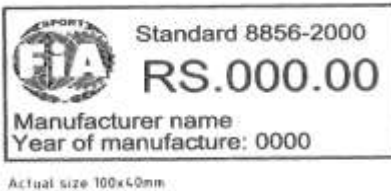

T14.6 Underclothing

It is strongly recommended that all competitors wear fire resistant underwear (long pants and long sleeve t-shirt) under their approved driving suit. This fire resistant underwear should be made from acceptable fire resistant material as listed in T14.12 and should cover the driver’s body completely from neck down to ankles and wrists.

NOTE: If you do not wear fire resistant underwear it is strongly recommended that you wear cotton underwear (t-shirt and long underpants) under your approved driving suit.

T14.7 Socks

Fire resistant socks made from acceptable fire resistant material as defined in T14.12, below, that cover the bare skin between the driver's suit and the boots or shoes.

T14.8 Shoes

Fire resistant shoes made from acceptable fire resistant material as defined in T14.12. The shoes must be certified to the standard and labeled as such:

- SFI 3.3
- FIA 8856-2000

T14.9 Gloves

Fire resistant gloves made from made from acceptable fire resistant material as defined in T14.12. Gloves of all leather construction or fire resistant gloves constructed using leather palms with no insulating fire resisting material underneath are not acceptable.

T14.10 Arm Restraints

Arm restraints are required and must be worn such that the driver can release them and exit the vehicle unassisted regardless of the vehicle's position. Arm restraints must be commercially manufactured. Arm restraints certified to SFI Standard 3.3 and labeled as such meet this requirement.

T14.11 Driver's Equipment Condition

All driving apparel must be in good condition. Specifically, driving apparel must not have any tears, rips, open seams, areas of significant wear or abrasion or stains which might compromise fire resistant performance.

T14.12 Fire Resistant Material

For the purpose of this section some, but not all, of the approved fire resistant materials are: Carbon X, Indura, Nomex, Polybenzimidazole (commonly known as PBI) and Proban.

T14.13 Synthetic Material – Prohibited

T-shirts, socks or other undergarments (not to be confused with FR underwear) made from nylon or any other synthetic material which will melt when exposed to high heat are prohibited.

T14.14 Fire Extinguishers

Each team must have at least two (2) 0.9 kg (2 lb.) dry chemical/dry powder fire extinguishers.

T14.14.1 Requirements for fire extinguishers may be different for each competition. Please check the rules and event website for any specific fire extinguisher requirements for the competition your team is attending.

T14.14.2 The following are the minimum ratings, any of which are acceptable at any Formula SAE Series event:

- USA, Canada & Brazil: 10BC or 1A 10BC
- Europe: 34B or 5A 34B
- Australia: 20BE or 1A 10BE

Extinguishers of larger capacity (higher numerical ratings) are acceptable.

Aqueous Film Forming Foam (AFFF) fire extinguishers are prohibited.

Halon extinguishers and systems are prohibited.

T14.14.3 All extinguishers must be equipped with a manufacturer installed pressure/charge gauge.

T14.14.4 Except for the initial inspection, one extinguisher must readily be available in the team's paddock area, and the second must accompany the vehicle wherever the vehicle is moved. Both extinguishers must be presented with the vehicle at Technical Inspection.

T14.14.5 As a team option, commercially available on-board fire systems are encouraged as an alternative to the extinguisher that accompanies the vehicle.

T14.14.6 Hand held fire extinguishers are **not** permitted to be mounted on or in the car.

- T14.15 Camera Mounts** - The mounts for video/photographic cameras must be of a safe and secure design.
- All camera installations must be approved at Technical Inspection.
 - Helmet mounted cameras and helmet camera mounts are prohibited.
 - The body of a camera or recording unit that weighs more than 0.25 kg (9 oz.) must be secured at a minimum of 2 points on different sides of the camera body. If a tether is used to restrain the camera, the tether length must be limited so that the camera cannot contact the driver.

NOTE: most GoPro cameras weigh less than 0.25kg.

ARTICLE 15: POSSIBLE FUTURE RULES CHANGES

Notice of Possible Rule Changes for the 2018-2019 Formula SAE Series

This section is intended to provide teams with advance notice of possible changes to the Formula SAE Rules that are being considered by the Formula SAE Rules Committee. Only changes that might have a significant influence on a team's design, manufacturing or operating decisions are listed.

The changes presented in this section are only possibilities and may not be implemented. This section is provided as information and is not intended to be the final text of the rules under consideration.

It is anticipated that this section of the regulations will be updated after feedback is received on these outline proposals. If any team has strong views on the proposals, then please send your feedback to www.fsaeonline.com. You may also email your feedback to kzundel@sae.org.

T15.1 Restriction on Professional Drivers – The Committee is considering prohibiting individuals who have driven for professionally funded teams from driving in FSAE dynamic events.

T15.2 Cockpit Templates – The committee is considering a smaller cockpit internal template along with a means to ensure that the front roll hoop bulkhead opening is sized adequately for the driver's legs.

T15.3 Cost Event – The committee is considering a major revamp of the cost event such that it addresses product / component engineering issues including design for cost, design for manufacturing, design for sustainability and the life cycle of the product. Students will be expected to have an appreciation of all areas of relating to product / component engineering which will be important in their engineering careers. The committee would appreciate feedback and proposals on how the cost event might be changed to improve its value to the students as part of this revamp.

T15.4 Event Points – The committee is considering more points for the Engineering Design event, which may be implemented as early as 2018. This is intended to include areas in addition to the onsite judging, such as the submitted documents or other special topics.

T15.5 Efficiency – The Committee is considering changing the way scores are determined for Efficiency. Multiple scoring methods for Combustion only, Electric only, and Combined Combustion/Electric events may be needed in order to score efficiency properly for each class. The influence of Endurance laptime on efficiency may be changed. Other ideas for changing the Efficiency event are welcomed.



APPENDIX T-1 STRUCTURAL EQUIVALENCY SPREADSHEET

Appendix T-1 is posted at www.fsaeonline.com.

APPENDIX T-2 IMPACT ATTENUATOR DATA REPORT

Appendix T-2 is posted at www.fsaeonline.com.

APPENDIX T-3 STANDARD IMPACT ATTENUATOR

For 2012 the standard attenuator may require the addition of a diagonal tube in the plane of the front bulkhead that connects two nodes. An optional configuration is an "X" brace that connects all four corners of the front bulkhead. For more information see the following pages.

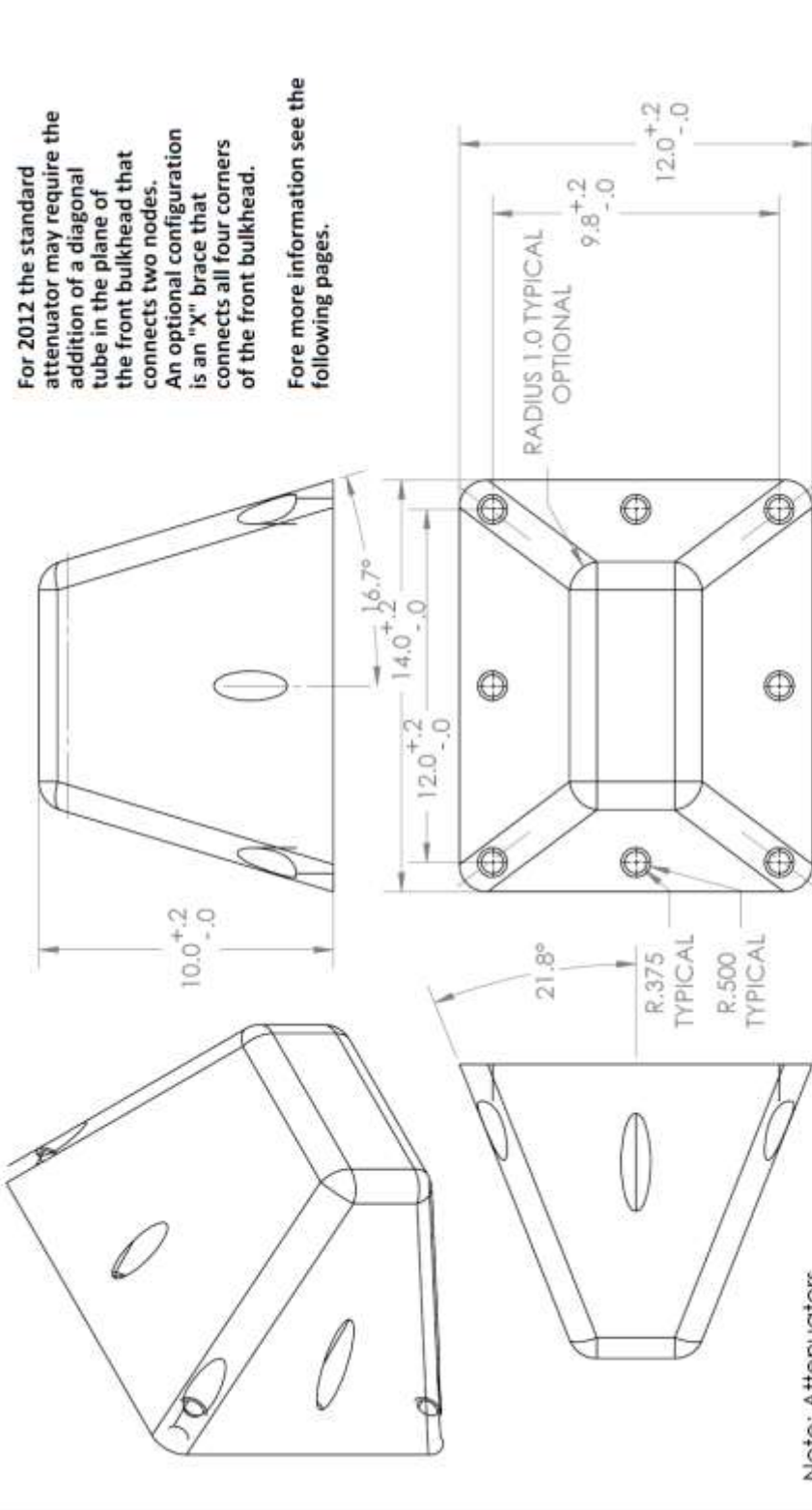

Note: Attenuators purchased from BSCI will not include optional radii on edges or mounting holes. Mounting holes shown are for reference only - attachment is up to the team to determine.

PROPRIETARY AND CONFIDENTIAL
THE INFORMATION CONTAINED IN THIS DRAWING IS COPYRIGHT 2011 BY SAE INTERNATIONAL

Updated	11/19/11	UNLESS OTHERWISE SPECIFIED: DIMENSIONS ARE IN INCHES TOLERANCES: FRACTIONAL ±0.015 ANGULAR: MACH 0.3 TWO PLACE DECIMAL ± 0.010 THREE PLACE DECIMAL ± 0.003	DRAWN CHECKED ENG APPR. MFG APPR. Q.A.	NAME WBR	DATE 3/14/11
HEAT TREAT	USED ON	MATERIAL Impax 700 Foam	The type 12 attenuator is unchanged from the 11 but for 2012 the additional front bulkhead diagonal tube is required, see note.		
APPLICATION	USED ON	FINISH	TITLE: FSAE Impact Attenuator Type 11		
5	4	3	SIZE DWG. NO. REV A FSAE-IA-12 1		
APPLICATION		DO NOT SCALE DRAWING	SCALE: 1:8 WEIGHT: SHEET 1 OF 1		



APPENDIX T-4

**FRONT BULKHEAD AND MAIN ROLL HOOP SUPPORT EXAMPLE
CONFIGURATIONS**

Appendix T-4 is posted at www.fsaeonline.com.

2017-18 FORMULA SAE RULES

PART AF - ALTERNATIVE FRAME RULES

ARTICLE 1: GENERAL REQUIREMENTS

These alternative structural requirements are intended to provide teams an alternative approach to the existing rules. The goal of these alternative rules is to provide a simpler alternative for monocoque designs and provide expanded design freedom for space frames and monocoques alike. The intent is not to alter allowable structures but to change the requirement process for showing compliance with the rules.

NOTE: Generally, SI units are used in these alternative frame rules with some dual references.

- AF1.1** Unless listed below under section AF7 and AF8 “Non-Applicable Rules” all requirements of the rest of the rules apply in these alternative requirements.
- AF1.2** The AF Rules are considered a work in progress. As such, the Rules Committee and reviewers of the SRCF (below) may, at any time, amend and clarify these rules to maintain the spirit in which they were written and close any unintended loop holes.
- AF1.3** These rules are recommended for existing teams who have experience designing, constructing and competition with vehicles in the past. There is no experience requirement.
- AF1.4** Notice of Intent - Teams planning to build a vehicle to this alternative rule set for entry into a North American competition must notify the Rules Committee of their intent by the date specified in the action deadlines for the competition. Include a short paragraph detailing your team’s finite element capability and showing you can meet all analytical requirements specified in this Appendix. Your “Notice of Intent” must include the email addresses and phones numbers of the team members who can answer any questions the Committee may have about your proposal.

The notice of intent submission should also include a brief report analyzing the sample structures problem posted to the SAE website. Please include a brief text description of your analysis approach, what software you used, the element types, mesh quality and boundary conditions that were used in this analysis. The results provided will be used to assess the team’s capability to perform this type of structural analysis.

- AF1.5** The Rules Committee will remain in contact with teams using the AF rules to help them develop and document their frames and to give the Committee data and feedback that can be used to refine the AF rules.
- AF1.6** Notice of Intent – Procedure
- Address – Teams using the AF Rules for a North America competition must submit their “Notice of Intent” to the FSAE Rules committee at: www.fsaonline.com.
 - Due Date – “Notices of Intent” to use the AF Rules the notice of intent must submitted to the Rules Committee by the date posted on the SAE Website.
 - Acknowledgement – The Rules Committee will review your “Notice of Intent” and will try to respond with their approval/disapproval within 15 days.

ARTICLE 2: STRUCTURAL REQUIREMENTS CERTIFICATION FORM (SRCF)

Since there is no baseline steel design in this alternative rule set, the team must show they are meeting the functional structural requirements.

When the Alternate Frame Rules are used the Structural Requirements Certification Form (SRCF) **supersedes** the Structural Equivalency Spreadsheet (SES) which **does not** have to be submitted.

AF2.1 SRCF - Submission Process

- a. Address – SRCFs must be submitted to the officials at the competition you are entering at the address indicated on the competition website or shown in the Appendix.
- b. Due Date and Late Submission Penalty – SRCFs must be submitted no later than the due date specified on the competition website (For US events reference “Action Deadlines”). Penalties for Late Submission will be imposed per A8.4.1. Acknowledgement – North American Competitions – SRCFs submitted for vehicles entered into competitions held in North America will be acknowledged upon receipt.

ARTICLE 3: DEFINITIONS

The following additional definitions apply throughout the Rules document in addition to the ones listed in T3.3

- a. Failure - Tensile, compressive, shear load or buckling critical load lower than the specified load. All failure modes have to be considered for every load case.
- b. Directions – The following coordinate system and labeling convention is used within these rules
 - Longitudinal (X)
 - Transverse (Y)
 - Vertical (Z)

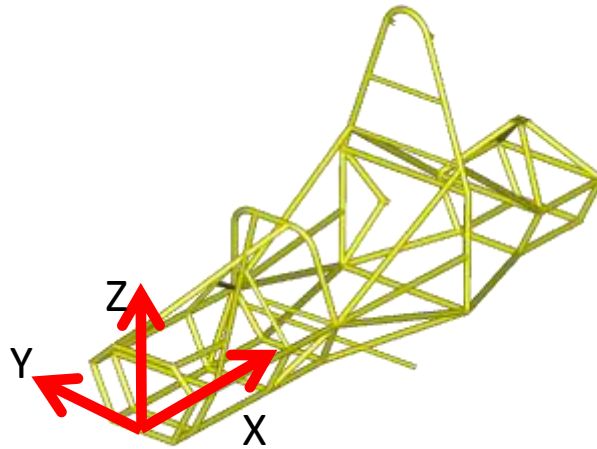

ARTICLE 4: STRUCTURAL REQUIREMENTS

AF4.1 Main Roll Hoop, Bracing and Bracing Supports

AF4.1.1 Load Applied: $F_x = 6.0 \text{ kN}$, $F_y = 5.0 \text{ kN}$, $F_z = -9.0 \text{ kN}$

AF4.1.2 Application point: Top of Main Roll Hoop

AF4.1.3 Boundary Condition: Fixed displacement (x, y, z) but not rotation of the bottom nodes of both sides of the front and main roll hoops.

AF4.1.4 Max Allowable Deflection: 25mm

AF4.1.5 Failure must not occur anywhere in structure

AF4.2 Front Roll Hoop

AF4.2.1 Load Applied: $F_x = 6.0$ kN, $F_y = 5.0$ kN, $F_z = -9.0$ kN

AF4.2.2 Application point: Top of Front Roll Hoop

AF4.2.3 Boundary Condition: Fixed displacement (x, y, z) but not rotation of the bottom nodes of both sides of the front and main roll hoops.

AF4.2.4 Max Allowable Deflection: 25mm

AF4.2.5 Failure must not occur anywhere in structure

AF4.3 Side Impact

AF4.3.1 Load Applied: $F_x = 0$ kN, $F_y = 7$ kN, $F_z = 0$ kN. Vector direction of lateral load to be in toward the driver.

AF4.3.2 Application point: All structural locations between front roll hoop and main roll hoop that are also required by AF6.4 (intrusion protection). Load may be distributed by the overlap of the impactor circle to the structural members. In Nastran this can be best accomplished through a “RBE3” (zero stiffness multi-point constraint) with the dependent node at the circle center and the independent nodes being all remaining nodes within a 5” (127 mm) radius. Most solvers have a similar type of element. The analysis may show worst case only but need to support choice of location to justify why it is worst.

AF4.3.3 Boundary Condition: Fixed displacement (x, y, z) but not rotation of the bottom nodes of both sides of the front and main roll hoops.

AF4.3.4 Max Allowable Deflection: 25 mm

AF4.3.5 Failure must not occur anywhere in structure

AF4.3.6 Accumulator Side Impact protection (EV cars only) use AF4.3 to satisfy EV3.4.4.

AF4.3.7 Tractive System Side Impact protection (EV cars only) use AF4.3 with a 5.5 kN load instead of 7 kN to satisfy EV4.2.2.

AF4.4 Front Bulkhead & Bulkhead Support

AF4.4.1 Load Applied: $F_x = 120$ kN, $F_y = 0$ kN, $F_z = 0$ kN.

AF4.4.2 Application point: use the actual attachment points between the impact attenuator and the front bulkhead

AF4.4.3 Boundary Condition: Fixed displacement (x, y, z) but not rotation of the bottom nodes of both sides of the main roll hoop and both locations where the main hoop and shoulder harness tube connect. Monocoques should use both sides of the bottom of the main hoop and both sides of the upper attachment point between the main hoop and monocoque.

AF4.4.4 Max Allowable Deflection: 25mm

AF4.4.5 Failure must not occur anywhere in structure

AF4.5 Shoulder Harness Attachment

AF4.5.1 Load Applied: 13- kN load for Monocoque chassis or 7kN load for steel space frames applied at each harness attachment point with the worst case for the range of angles specified in T5.4.3.

AF4.5.2 Application point: Both harness attachment points simultaneously

AF4.5.3 Boundary Condition: Fixed displacement (x, y, z) but not rotation of the bottom nodes of both sides of the front and main roll hoops.

AF4.5.4 Max Allowable Deflection: 25mm

AF4.5.5 Failure must not occur anywhere in structure

AF4.6 Lap & Anti-Submarine AF Harness Attachment

AF4.6.1 Load Applied: 13kN load applied at each lap belt attachment point with the worst case for the range of angles specified in T5.3.5. 6.5 kN load applied at each sub-marine belt attachment point with the worst case for the range of angles specified in T5.3.5. If the lap and sub-marine belts share the same attachment points, then a 19.5 kN load is applied at each belt attachment point with the worst case for the range angles specified in T5.3.5.

AF4.6.2 Application point: All harness attachment points simultaneously (same load case)

AF4.6.3 Boundary Condition: Fixed displacement (x, y, z) but not rotation of the bottom nodes of both sides of the front and main roll hoops.

AF4.6.4 Max Allowable Deflection: 25mm

AF4.6.5 Failure must not occur anywhere in structure

AF4.7 Front Bulkhead & Bulkhead Support Off Axis

AF4.7.1 Load Applied: $F_x = 120 \text{ kN}$, $F_y = 10.5 \text{ kN}$, $F_z = 0 \text{ kN}$.

AF4.7.2 Application point: Create load application node in the front bulkhead plane at the center of the front bulkhead. Load application node may be rigidly connected to the front bulkhead and impact attenuator attachment points.

AF4.7.3 Boundary Condition: Fixed displacement (x, y, z) but not rotation of the bottom nodes of both sides of the main roll hoop and both locations where the main hoop and shoulder harness tube connect. Monocoques should use both sides of the bottom of the main hoop and both sides of the upper attachment point between the main hoop and monocoque.

AF4.7.4 Max Allowable Deflection: 25mm

AF4.7.5 Failure must not occur anywhere in structure

AF4.8 Accumulator Container (EV cars)

AF4.8.1 Load on the Accumulator container structure is applied by loads located at the center of gravity of each section of cells/segments. The magnitude of the loads is the mass times acceleration.

- AF4.8.2 Apply the following accelerations for a chassis that separates the Accumulator from the driver by structure equivalent to “side impact structure”.
- 20g in the longitudinal direction (forward/aft)
 - 20g in the lateral (left/right)
 - 20g vertical (up/down) direction.

- AF4.8.3 Chassis that separates the driver from the Accumulator with side impact structure must use an “impactor circle” with a diameter equal to the minimum width or height dimension of the accumulator.

NOTE: the impactor circle is used to define the maximum gap allowed for side impact structure and to distribute side impact loads. AF4.8.3 only applies to side impact structure between the driver and the accumulator.

- AF4.8.4 Apply the following accelerations for a chassis that does not separate the Accumulator from the driver by structure equivalent to “side impact structure”.
- 40g in the longitudinal direction (forward/aft)
 - 40g in the lateral (left/right)
 - 20g vertical (up/down) direction.

- AF4.8.5 Boundary Condition: Fixed displacement (x, y, z) but not rotation of the bottom nodes of both sides of the front and main roll hoops.

ARTICLE 5: GENERAL ANALYSIS REQUIREMENTS

The following requirements apply to the submitted structural certification process.

- AF5.1** Good analysis practice must be used and all assumptions and modeling approximations are subject to approval during the SRC process. This includes but is not limited to mechanical properties, mesh size and mesh quality.
- AF5.2** A Nastran analysis deck and supporting documentation must be submitted electronically with the “Notice of Intent” and SRCF. Nastran does not have to be used for the analysis, but is the required format for the organizers to review the analysis input decks.
- AF5.3** Tubes with wall thickness less than 0.047 inches (or an approved alternative as per rules T3.5, T3.6 or T3.7) cannot be included in the analysis.
- AF5.4** Holes in tubes may be neglected from the overall frame/monocoque model global results. However, for each load case, the force and moments at both sides of the tubes need to be applied to a shell or solid model of the tube with the hole or cutout geometry modeled. The tube around the holes and cutouts may not show failure.
- AF5.5** Offsets between tubes at nodes need a detailed analysis similar to 5.3 where the actual connection is modeled using the end constraints from the overall vehicle model. Shell or solid models must be used.
- AF5.6** The following alternative boundary condition is acceptable for all structural requirements. The alternative is to not include the nodal constraints and instead run the model with inertia relief. In this case the mass distribution of the vehicle must closely approximate the actual intended mass distribution. Evidence must be provided supporting the mass distribution used in the model. A driver

mass of 77 kg and a minimum vehicle mass of 300 kg must be used, even if these differ from the team's predicted vehicle mass.

ARTICLE 6: INTRUSION PREVENTION

Since the exact configuration of the tubes is not specified this rule is intended to limit the size of object which can intrude into the driver's cell.

- AF6.1** An impactor is defined as a circular disk with diameter of 254 mm (10 inches). The thickness is not relevant, but will generally be around 2mm (0.080 inches) for the inspection process.
- AF6.2** The primary structure between the front bulkhead and main roll hoop must not allow the impactor to enter the primary structure.
- AF6.3** Anywhere on the structure where the impactor is attempted to be passed through the impactor must contact the structure in at least three points. This is not a projection requirement but a full 3-dimensional requirement.

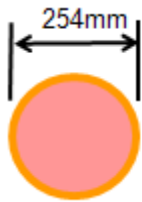

Impactor Check – must not be able to enter frame at any point between front bulkhead and main roll hoop – must contact three points of frame everywhere in side projection

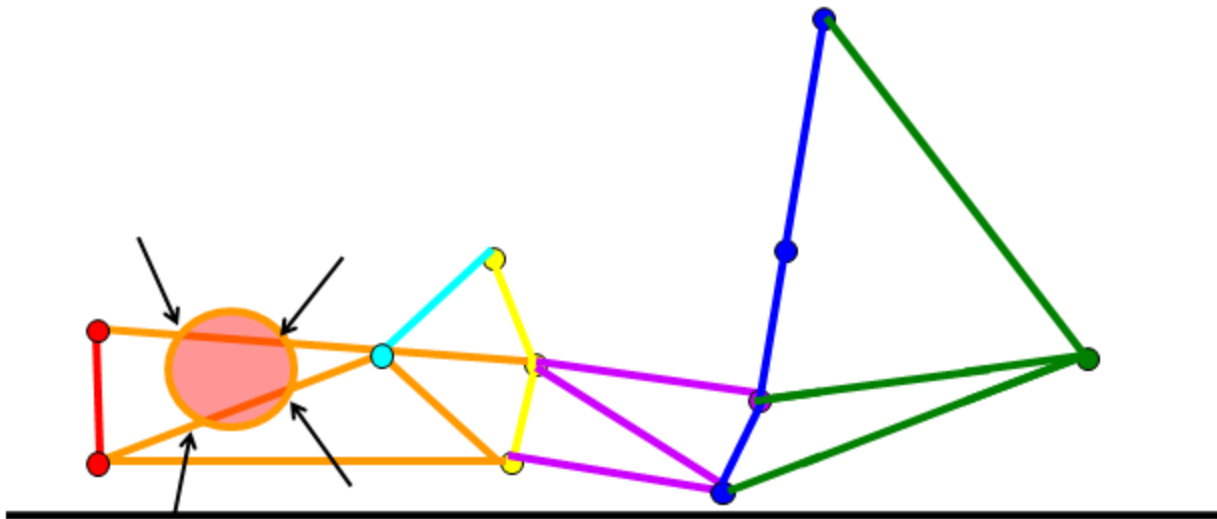

- AF6.4** The impactor is a 3-dimensional requirement. It applies to all faces of the structure, including the front, sides, top, floor and rear, excluding only the cockpit opening specified in T4.1.1. If the driver is seated fully in front of the main hoop, then the requirement does not apply behind the main hoop. If the driver is seated partially or fully behind the main hoop, then the requirement extends to the end of the main hoop braces. The impactor requirement does not apply to openings or gaps that are entirely above a plane parallel to and 350 mm above the ground.

ARTICLE 7: NON-APPLICABLE RULES: CHASSIS/FRAME

The following rules are **not** applicable when building a frame to this alternative rule set.

- AF7.1** T3.11.4 In the side view of the vehicle, the portion of the Main Roll Hoop that lies above its...
- AF7.2** T3.12.6 In side view, no part of the Front Hoop can be inclined at more than twenty degrees...
- AF7.3** T3.13.3 In the side view of the Frame, the Main Hoop and the Main Hoop braces must not lie...
- AF7.4** T3.13.4 The Main Hoop braces must be attached as near as possible to the top of the Main Hoop...
- AF7.5** T3.13.6 The Main Hoop Braces must be securely integrated into the Frame and be capable of ...
- AF7.6** T3.14.4 The Front Hoop braces must be attached as near as possible to the top of the Front Hoop...
- AF7.7** T3.14.5 If the Front Hoop leans rearwards by more than ten degrees (10°) from the vertical, it ...
- AF7.8** T3.19.1 The Front Bulkhead must be securely integrated into the Frame.
- AF7.9** T3.19.2 The Front Bulkhead must be supported back to the Front Roll Hoop by a minimum of...
- AF7.10** T3.24.4 With proper triangulation, it is permissible to fabricate the Side Impact Structural...
- AF7.11** T3.31 Monocoque Front Bulkhead Support
- AF7.12** T3.32.1 In addition to proving that the strength of the monocoque is adequate, the monocoque...
- AF7.13** T3.32.2 The EI of the vertical side of the front bulkhead support structure must be equivalent...
- AF7.14** T3.33.1 In the region longitudinally forward of the Main Roll Hoop and aft of the Front Roll...
- AF7.15** T3.33.2 The vertical side impact zone between the upper surface of the floor and 350 mm...
- AF7.16** T3.33.3 The vertical side impact zone between the upper surface of the floor and 350 mm...
- AF7.17** T3.36 Monocoque Front and Main Hoop Bracing
- AF7.18** PART EV - EV3.4.4 All accumulator containers must be protected from side or rear impact collisions by...
- AF7.19** PART EV - EV4.2.2 If tractive system parts are mounted in a position where damage could occur from a...

ARTICLE 8: NON-APPLICABLE RULES: ACCUMULATOR CONTAINER

The following rules are not applicable when building an accumulator container to this alternative rule set.

- AF8.1** PART EV - EV3.4.6 Accumulator containers must be constructed of sheet/plate steel or aluminum in the...

2017-18 FORMULA SAE RULES PART IC - INTERNAL COMBUSTION ENGINE VEHICLES

ARTICLE 1: INTERNAL COMBUSTION ENGINE POWERTRAINS

IC1.1 Engine Limitation

IC1.1.1 The engine(s) used to power the car must be a piston engine(s) using a four-stroke primary heat cycle with a displacement not exceeding 710 cc per cycle. Hybrid powertrains, such as those using electric motors running off stored energy, are prohibited.

NOTE: All waste/rejected heat from the primary heat cycle may be used. The method of conversion is not limited to the four-stroke cycle.

IC1.1.2 The engine may be modified within the restrictions of the rules.

IC1.1.3 If more than one engine is used, the total displacement must not exceed 710 cc and the air for all engines must pass through a single air intake restrictor (see IC1.6 “Intake System Restrictor.”)

IC1.2 Engine Inspection

The organizer will measure or tear down a substantial number of engines to confirm conformance to the rules. The initial measurement will be made externally with a measurement accuracy of one (1) percent. When installed to and coaxially with spark plug hole, the measurement tool has dimensions of 381 mm (15 inches) long and 30 mm (1.2 inches) diameter. Teams may choose to design in access space for this tool above each spark plug hole to reduce time should their vehicle be inspected.

IC1.3 Starter

Each car must be equipped with an on-board starter which, during the competition, must be used to start the car at all times. Push starts, or the use of a remote starter, are prohibited.

IC1.4 Air Intake System

IC1.4.1 Air Intake System Location

All parts of the engine air and fuel control systems (including the throttle or carburetor, and the complete air intake system, including the air cleaner and any air boxes) must lie within the surface defined by the top of the roll bar and the outside edge of the four tires. (See Figure 13).

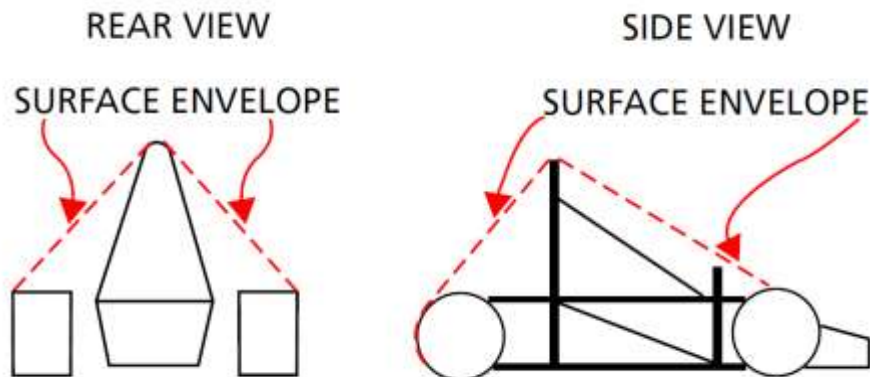

Figure 13

IC1.4.2 Any portion of the air intake system that is less than 350 mm (13.8 inches) above the ground must be shielded from side or rear impact collisions by structure built to Rule T3.24 or T3.33 as applicable.

IC1.4.3 Intake Manifold – The intake manifold must be securely attached to the engine block or cylinder head with brackets and mechanical fasteners. This precludes the use of hose clamps, plastic ties, or safety wires. The use of rubber bushings or hose is acceptable for creating and sealing air passages, but is not considered a structural attachment. The threaded fasteners used to secure the intake manifold are considered critical fasteners and must comply with ARTICLE 11.

IC1.4.4 Intake systems with significant mass or cantilever from the cylinder head must be supported to prevent stress to the intake system. Supports to the engine must be rigid. Supports to the frame or chassis must incorporate some isolation to allow for engine movement and chassis flex.

IC1.5 Throttle and Throttle Actuation

IC1.5.1 Carburetor/Throttle Body

The car must be equipped with a carburetor or throttle body. The carburetor or throttle body may be of any size or design.

IC1.5.2 Throttle Actuation

The throttle must be actuated mechanically, i.e. via a cable or a rod system, unless IC1.11 - IC1.16 is followed for Electronic Throttle Control which replaces the rest of IC1.5

IC1.5.3 The throttle cable or rod must have smooth operation, and must not have the possibility of binding or sticking.

IC1.5.4 The throttle actuation system must use at least two (2) return springs located at the throttle body, so that the failure of any component of the throttle system will not prevent the throttle returning to the closed position.

Throttle Position Sensors (TPS) are NOT acceptable as return springs.

IC1.5.5 Throttle cables must be at least 50.8 mm (2 inches) from any exhaust system component and out of the exhaust stream.

IC1.5.6 A positive pedal stop must be incorporated on the throttle pedal to prevent over stressing the throttle cable or actuation system.

IC1.5.7 The throttle pedal cable must be protected from being bent or kinked by the driver's foot when it is operated by the driver or when the driver enters or exits the vehicle.

IC1.5.8 If the throttle system contains any mechanism that could become jammed, for example a gear mechanism, then this must be covered to prevent ingress of any debris.

IC1.5.9 Carburetors are not allowed on boosted applications.

IC1.6 Intake System Restrictor

IC1.6.1 In order to limit the power capability from the engine, a single circular restrictor must be placed in the intake system and all engine airflow must pass through the restrictor. The only allowed sequence of components are the following:

- a. For naturally aspirated engines, the sequence must be (see Fig 1): throttle body, restrictor, and engine.
- b. For turbocharged or supercharged engines, the sequence must be (see Fig 2): restrictor, compressor, throttle body, engine.

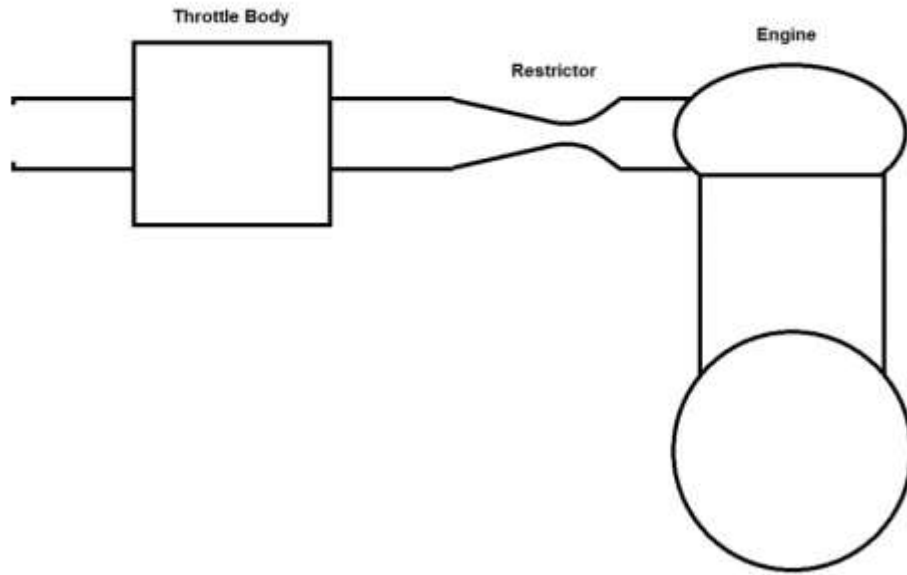

Figure 1

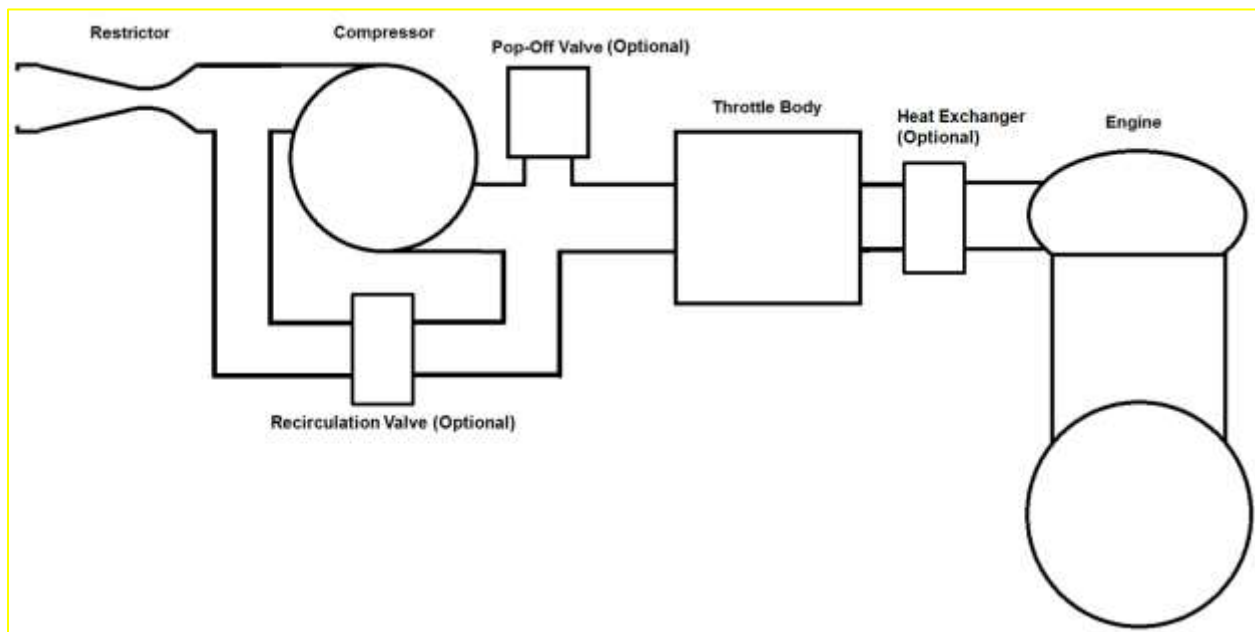

Figure 2

- IC1.6.2 The maximum restrictor diameters at any time during the competition are:
- Gasoline fueled cars - 20.0 mm (0.7874 inch)
 - E-85 fueled cars – 19.0 mm (0.7480 inch)
- IC1.6.3 The restrictor must be located to facilitate measurement during the inspection process.
- IC1.6.4 The circular restricting cross section may NOT be movable or flexible in any way, e.g. the restrictor may not be part of the movable portion of a barrel throttle body.
- IC1.6.5 If more than one engine is used, the intake air for all engines must pass through the one restrictor.

IC1.7 Turbochargers & Superchargers

- IC1.7.1 The restrictor must be placed upstream of the compressor and the throttle body must be placed downstream of the compressor. Thus, the only sequence allowed is restrictor, compressor, throttle body, engine as described in IC1.6.1 (b).
- IC1.7.2 The intake air may be cooled with an intercooler (a charge air cooler). Only ambient air may be used to remove heat from the intercooler system. Air-to-air and water-to-air intercoolers are permitted. The coolant of a water-to-air intercooler system must comply with Rule T8.1.
- IC1.7.3 If pop-off valves, recirculation valves, or heat exchangers (intercoolers) are used, they may only be positioned in the intake system as shown in IC1.6.1 Figure 2.
- IC1.7.4 Plenums anywhere upstream of the throttle body are prohibited. For the purpose of definition, a “plenum” is any tank or volume that is a significant enlargement of the normal intake runner system. Teams are encouraged to submit their designs to the Rules Committee for review prior to competition if the legality of their proposed system is in doubt.
- IC1.7.5 The maximum allowable ID of the intake runner system between the restrictor and throttle body is 60 mm diameter, or the equivalent area (i.e. 2827 mm²) if non-circular.
- IC1.7.6 If an intercooler/aftercooler is used, it must be located downstream of the throttle body.

IC1.8 Fuel Lines

- IC1.8.1 Plastic fuel lines between the fuel tank and the engine (supply and return) are prohibited.
- IC1.8.2 If rubber fuel line or hose is used, the components over which the hose is clamped must have annular bulb or barbed fittings to retain the hose. Also, clamps specifically designed for fuel lines must be used. These clamps have three (3) important features, (i) a full 360-degree (360°) wrap, (ii) a nut and bolt system for tightening, and (iii) rolled edges to prevent the clamp cutting into the hose. Worm-gear type hose clamps are not approved for use on any fuel line.
- IC1.8.3 Fuel lines must be securely attached to the vehicle and/or engine.
- IC1.8.4 All fuel lines must be shielded from possible rotating equipment failure or collision damage.

IC1.9 Fuel Injection System Requirements

The following requirements apply to fuel injection systems.

IC1.9.1 Low Pressure Injection (LPI)

Low pressure fuel injection systems are those functioning at a pressure below 10 Bar (145 psi). Most Port Fuel Injected (PFI) fuel systems are low pressure.

- a. **Fuel Lines** – On low pressure fuel injected systems, any flexible fuel lines must be either (i) metal braided hose with either crimped-on or reusable, threaded fittings, or (ii) reinforced rubber hose with some form of abrasion resistant protection with fuel line clamps per IC1.8.2. **Hose clamps over metal braided hose will not be accepted.**
- b. **Fuel Rail** – The fuel rail must be securely attached to the engine cylinder block, cylinder head, or intake manifold with mechanical fasteners. This precludes the use of hose clamps, plastic ties, or safety wire. The threaded fasteners used to secure the fuel rail are considered critical fasteners and must comply with ARTICLE 11. The use of fuel rails made from plastic,

carbon fiber or rapid prototyping flammable materials is prohibited. However, the use of unmodified OEM Fuel Rails manufactured from these materials is acceptable.

- c. **Intake Manifold** – On engines with port fuel injection, the intake manifold must be securely attached to the engine block or cylinder head.

IC1.9.2 High Pressure Injection (HPI) / Direct Injection (DI)

High pressure fuel systems are those functioning at 10 Bar (145 psi) pressure or above. Direct injection fuel systems are those where the injection occurs directly into the combustion system. DI systems often utilize a low pressure electric fuel pump and high pressure mechanical “boost” pump driven off the engine. The high pressure lines are those between the boost pump and injectors, and the low pressure lines lead from the tank to the electric supply pump up to the boost pump.

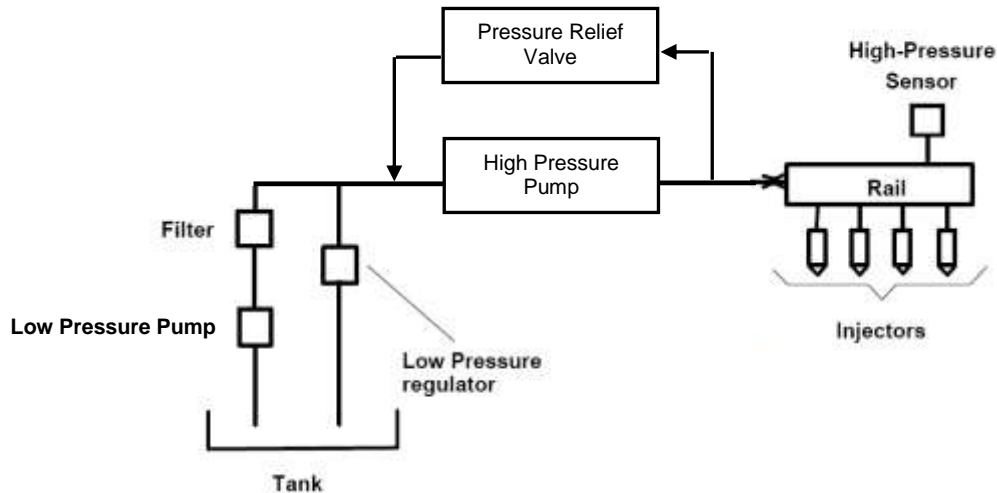

- a. **High Pressure Fuel Lines** – All high pressure fuel lines, normally those downstream of the high pressure pump on Direct Injection systems, must be stainless steel rigid line or Aeroquip FC807 smooth bore PTFE hose with stainless steel reinforcement and visible Nomex tracer yarn. Equivalent products may be used with prior Rules Committee approval. Use of elastomeric seals is prohibited. Lines must be rigidly connected every 100mm by mechanical fasteners to structural engine components such as cylinder heads or block.
- b. **Low Pressure Fuel Lines** – Low pressure lines, normally those upstream of the high pressure pump, that are flexible must be either (i) metal braided hose with either crimped-on or reusable, threaded fittings, or (ii) reinforced rubber hose with some form of abrasion resistant protection with fuel line clamps per IC1.8.2. Hose clamps over metal braided hose will not be accepted.
- c. **Fuel Rail** – The fuel rail must be securely attached to the engine cylinder head with mechanical fasteners. This precludes the use of hose clamps, plastic ties, or safety wire. The fastening method must be sufficient to hold the fuel rail in place with the maximum regulated pressure acting on the injector internals and neglecting any assistance from in-cylinder pressure acting on the injector tip. The threaded fasteners used to secure the fuel rail are considered critical fasteners and must comply with ARTICLE 11.
- d. **High Pressure Fuel Pump** – The fuel pump must be rigidly mounted to structural engine components such as the cylinder head or engine block.

- e. **Pressure Regulator** – A fuel pressure regulator must be fitted between the high and low pressure sides of the fuel system in parallel with the DI boost pump. The external regulator must be used even if the DI boost pump comes equipped with an internal regulator.
- f. **Required Test** – Prior to the tilt test specified in T8.5, engines fitted with mechanically actuated fuel pumps must be run to fill and pressure the system downstream of the high pressure pump.

IC1.10 Crankcase / engine lubrication venting

IC1.10.1 Any crankcase or engine lubrication vent lines routed to the intake system must be connected upstream of the intake system restrictor.

IC1.10.2 Crankcase breathers that pass through the oil catch tank(s) to exhaust systems, or vacuum devices that connect directly to the exhaust system, are prohibited.

IC1.11 Electronic Throttle Control - ETC

IC1.11.1 Electronic Throttle Control (Drive-by-wire control) of the throttle position is permitted if a technical description of the system and FMEA is submitted prior to the event which describes the expected failure modes and how the strategy to detect and respond to those failure modes is implemented. The purpose of this is to show that good engineering practices have been applied to the ETC. If an adequate FMEA is not presented, then the team will be required to convert to a mechanical throttle. In any case, rules IC1.11 – IC1.16 apply if an electronic throttle is implemented. A notice of intent is required for any team wishing to follow the ETC regulations. See IC1.17 and IC1.18 for submission requirements.

IC1.11.2 An ETC system that is commercially available, but does not comply with the regulations, may be used, if approved by the competition organizer. To obtain approval, the team must:

- Submit a rules question to ask your event organizers if that ETC system may be used.
- Include the specific ETC rule(s) that the commercial system deviates from.
- Include sufficient technical details of these deviations to allow the acceptability of the commercial system to be determined.

IC1.11.3 The electronic throttle must automatically close (return to idle) when power is removed from it.

IC1.11.4 The electronic throttle must use at least two (2) sources of energy capable of returning the throttle to the idle position. One of the sources may be the device that normally actuates the throttle, e.g. a DC motor, but the other device(s) must be a throttle return spring that can return the throttle to the idle position in the event of a loss of actuator power.

Springs in the TPS are not acceptable throttle return springs

IC1.12 Throttle Position Sensor – TPS

IC1.12.1 The TPS must measure the position of the throttle or the throttle actuator. Throttle position is defined as percent of travel from fully closed to wide open where 0% is fully closed and 100% is fully open.

IC1.12.2 At least two separate sensors have to be used as TPSs. The TPSs may share the same supply and reference lines only if effects of supply and/or reference line voltage offsets can be detected.

IC1.12.3 If an implausibility occurs between the values of the two TPSs and persists for more than 100msec, the power to the electronic throttle must be immediately shut down.

- IC1.12.4 Implausibility is defined as a deviation of more than 10% throttle position between the sensors or other failure as defined in IC1.12. Use of larger values may be considered on a case by case basis and require justification in the FMEA.
- IC1.12.5 If three sensors are used, then in the case of a TPS failure, any two TPSs that agree within 10% throttle position may be used to define the throttle position target and the 3rd TPS may be ignored.
- IC1.12.6 Each TPS must have a separate detachable connector that enables a check of these functions by unplugging it during Technical Inspection, else, an inline switchable break-out box must be made available during Technical Inspection that allows disconnection of the each TPS signal.
- IC1.12.7 The TPS signals must be sent directly to the throttle controller using an analogue signal or via a digital data transmission bus such as CAN or FlexRay. Any failure of the TPSs or TPS wiring must be detectable by the controller and must be treated like implausibility.
- IC1.12.8 When an analogue signal is used, e.g. from a 5V sensor, the TPSs will be considered to have failed when they achieve an open circuit or short circuit condition which generates a signal outside of the normal operating range, for example <0.5V or >4.5V. The circuitry used to evaluate the sensor will use pull down or pull up resistors to ensure that open circuit signals result in a failure being detected.
- IC1.12.9 When any kind of digital data transmission is used to transmit the TPS signal, the FMEA study must contain a detailed description of all the potential failure modes that can occur, the strategy that is used to detect these failures and the tests that have been conducted to prove that the detection strategy works. The failures to be considered must include but are not limited to the failure of the TPS, TPS signals being out of range, corruption of the message and loss of messages and the associated time outs.

IC1.13 Accelerator Pedal Position Sensor – APPS

- IC1.13.1 The APPS must be actuated by a foot pedal. Pedal travel is defined as percent of travel from a fully released position to a fully applied position where 0% is fully released and 100% is fully applied.
- IC1.13.2 The foot pedal must return to its original position when not actuated. The foot pedal must have a positive stop preventing the mounted sensors from being damaged or overstressed. Two (2) springs must be used to return the throttle pedal to the off position and each spring must be capable of returning the pedal to the off position with the other disconnected.

The springs in the APPSs are not acceptable pedal return springs.

- IC1.13.3 At least two entirely separate sensors have to be used as APPSs. The sensors must have different transfer functions, each having a positive slope sense with either different gradients and/or offsets to the other(s).

NOTE: The intent of this rule is that in a short circuit the APPSs will only agree at 0% pedal position.

- IC1.13.4 If implausibility occurs between the values of the two APPSs and persists for more than 100msec, power to the electronic throttle must be immediately shut down.
- IC1.13.5 Implausibility is defined as a deviation of more than 10% pedal travel between the sensors or other failure as defined in IC1.13. Use of larger values may be considered on a case by case basis and require justification in the FMEA.

- IC1.13.6 If three sensors are used, then in the case of an APPS failure, any two APPSs that agree within 10% pedal travel may be used to define the throttle position target and the 3rd APPS may be ignored.
- IC1.13.7 Each APPS must have a separate detachable connector that enables a check of these functions by unplugging it during Technical Inspection, else, an inline switchable break-out box must be made available during Technical Inspection that allows disconnection of each APPS signal.
- IC1.13.8 The APPS signals must be sent directly to the throttle controller using an analogue signal or via a digital data transmission bus such as CAN or FlexRay. Any failure of the APPSs or APPS wiring must be detectable by the controller and must be treated like an implausibility.
- IC1.13.9 When an analogue signal is used, e.g. from a 5V sensor, the APPSs will be considered to have failed when they achieve an open circuit or short circuit condition which generates a signal outside of the normal operating range, for example $<0.5V$ or $>4.5V$. The circuitry used to evaluate the sensor will use pull down or pull up resistors to ensure that open circuit signals result in a failure being detected.
- IC1.13.10 When any kind of digital data transmission is used to transmit the APPS signal, the FMEA study must contain a detailed description of all the potential failure modes that can occur, the strategy that is used to detect these failures and the tests that have been conducted to prove that the detection strategy works. The failures to be considered must include but are not limited to the failure of the APPS, APPS signals being out of range, corruption of the message and loss of messages and the associated time outs.
- IC1.13.11 Any algorithm or electronic control unit that can manipulate the APPS signal, for example for vehicle dynamic functions such as traction control, may only lower the total driver requested torque and must never increase *torque* unless it is exceeded during a gearshift. Thus the drive torque which is requested by the driver may never be exceeded.
- IC1.14 Brake System Encoder – BSE**
- IC1.14.1 A brake system encoder to measure brake pedal position or brake system pressure must be fitted to check for plausibility.
- IC1.14.2 The BSE must have a separate detachable connector that enables detection of error states and the response of the ECU to be checked by unplugging it during Technical Inspection, otherwise an inline switchable break-out box must be made available during technical inspection that allows disconnection of each BSE signal.
- IC1.14.3 The BSE signals must be sent directly to the throttle controller using an analogue signal or via a digital data transmission bus such as CAN or FlexRay. Any failure of the BSE or BSE wiring that persists more than 100msec must be detectable by the controller and must be treated like an implausibility such that power to the electronic throttle is immediately shut down.
- IC1.14.4 When an analogue signal is used, e.g. from a 5V sensor, the BSE will be considered to have failed when they achieve an open circuit or short circuit condition which generates a signal outside of the normal operating range, for example $<0.5V$ or $>4.5V$. The circuitry used to evaluate the BSE will use pull down or pull up resistors to ensure that open circuit signals result in a failure being detected.
- IC1.14.5 When any kind of digital data transmission is used to transmit the BSE signal, the FMEA study must contain a detailed description of all the potential failure modes that can occur, the strategy that is used to detect these failures and the tests that have been conducted to prove that the detection strategy works. The failures to be considered must include but are not limited to the failure of the BSE, BSE

signals being out of range, corruption of the message and loss of messages and the associated time outs.

IC1.15 ETC Plausibility Checks

- IC1.15.1 The power to the electronic throttle must be immediately shut down, if the mechanical brakes are actuated and the TPS signals that the throttle is open by more than a permitted amount for more than 1(one) second.

An interval of 1 (one) second is allowed for the throttle to close (return to idle), failure to achieve this within the required interval must result in immediate shut down of the power to the fuel injectors and/or the ignition system.

The permitted relationship between BSE and TPS may be defined by the team using a table, but the functionality must be demonstrated at Technical Inspection.

- IC1.15.2 The power to the electronic throttle must be immediately shut down, if throttle position differs by more than 10% from the expected target TPS position for more than 1 second.

An interval of 1 (one) second is allowed for the difference to reduce to less than 10%, failure to achieve this within the required interval must result in immediate shut down of the power to the fuel injectors and/or the ignition system.

An error in TPS position and the resultant system shutdown must be demonstrated at Technical Inspection.

The electronic throttle and fuel injector/ignition system shutdown must remain active until the TPS signals indicate the throttle is at or below the unpowered default position, for at least 1 (one) second.

IC1.16 Brake System Plausibility Device for IC Engines with ETC

A standalone non-programmable circuit must be used on the car such that when braking hard (for example >0.8g deceleration but without locking the wheels) and when the TPS shows that the throttle is greater than 10% open, the power to the electronic throttle and fuel pump must be completely shut down and this must result in the electronic throttle closing to the idle position. The action of removing power to the electronic throttle and fuel pump must occur if the implausibility is persistent for more than one (1) second. This device must be provided in addition to the plausibility checks which are carried out in the ETC which interprets the drivers throttle request and controls the engine throttle position. The Brake Plausibility Device may only be reset by power cycling the Primary Master Switch.

The team must devise a test to prove this required function during Technical Inspection. However, it is suggested that it should be possible to achieve this by sending an appropriate signal to the non-programmable circuit that represents a throttle position of more than 10% whilst pressing the brake pedal to a position or with a force that represents hard braking.

IC1.17 ETC – Notice of Intent

- IC1.17.1 Notice of Intent - Teams planning to build an electronically controlled throttle complying with IC1.11-IC1.16 for entry into a North American competition must notify the Rules Committee of their intent by the date specified in the action deadlines for the competition. Include a short paragraph detailing your team's outline design and showing that you have the capability to design the electronic systems. Your "Notice of Intent" must include the email addresses and phones numbers of the team members who can answer any questions the Committee may have about your proposal.



IC1.17.2 Failure to submit a notice of intent by the due date will mean that teams may only compete with a mechanical throttle.

IC1.17.3 Competitions may choose to apply limits to the number of ETC entries that they allow and therefore the Notice of Intent may be used to screen which teams are accepted to build an ETC to the appropriate regulations.

IC1.18 Failure Modes and Effects Analysis (FMEA)

IC1.18.1 Assuming that the notice of intent is accepted, teams must submit a complete failure modes and effects analysis (FMEA) of the Electronic Throttle Control prior to the event which includes a description of the system.

IC1.18.2 A template including required failures to be described will be made available online – see your competition website for details.

Do not change the format of the template. Pictures, schematics and data sheets to be referenced in the FMEA have to be included in the FMEA on additional table pages

IC1.18.3 Submission of the FMEA

Failure Modes and Effects Analysis (FMEA) must be submitted in compliance with the procedure and by the deadline published on the website of the competition your team is attending.

IC1.18.4 Penalty for Late Submission or Non-submission

Late submission of the FMEA will require the team to revert to a mechanical throttle arrangement.

ARTICLE 2: FUEL AND FUEL SYSTEM

IC2.1 Fuel

The basic fuel available at competitions in the Formula SAE Series is unleaded gasoline. For the FSAE North American competitions this should have an octane rating of 91 (R+M)/2 (approximately 95 RON) minimum and for other competitions, the unleaded gasoline that will be available will be published by the relevant organizing committee. However, the basic fuel may be changed at the discretion of the organizing body. Other fuels may be available at the discretion of the organizing body.

IC2.1.1 Unless otherwise announced by the individual organizing body, the fuel at competitions in the Formula SAE Series will be provided by the organizer.

IC2.1.2 During all performance events the cars must be operated with the fuels provided by the organizer at the competition.

IC2.1.3 Nothing may be added to the provided fuels. This prohibition includes nitrous oxide or any other oxidizing agent.

NOTE 1: Teams are advised that the fuel supplied in the United States is subject to various federal and state regulations and may contain ethanol. The exact chemical composition and physical characteristics of the available fuel may not be known prior to the competition.

NOTE 2: The fuels provided at Formula SAE Michigan and Formula SAE Lincoln are expected to be 93 and 100 octanes [(R+M)/2] gasoline and E-85. Fuel types are subject to change. Consult the individual competition websites for fuel types and other information.

NOTE 3: The fuels provided at FSAE competitions depend on the grades the suppliers have available. Although the organizers make every effort to provide the announced fuels, events beyond our control may require substitutions. We strongly advise teams to monitor the competition websites for updated information on fuel types.

IC2.2 Fuel Additives - Prohibited

IC2.2.1 No agents other than fuel (gasoline or E85), and air may be induced into the combustion chamber. Non-adherence to this rule will be reason for disqualification.

IC2.2.2 Officials may inspect the oil.

IC2.3 Fuel Temperature Changes - Prohibited

The temperature of fuel introduced into the fuel system may not be changed with the intent to improve calculated efficiency.

IC2.4 Fuel Tanks

IC2.4.1 The fuel tank is defined as that part of the fuel containment device that is in contact with the fuel. It may be made of a rigid material or a flexible material.

IC2.4.2 Fuel tanks made of a rigid material must not be used to carry structural loads, e.g. from roll hoops, suspension, engine or gearbox mounts, and must be securely attached to the vehicle structure with mountings that allow some flexibility such that chassis flex cannot unintentionally load the fuel tank.

IC2.4.3 Any fuel tank that is made from a flexible material, for example a bladder fuel cell or a bag tank must be enclosed within a rigid fuel tank container which is securely attached to the vehicle structure. Fuel tank containers (containing a bladder fuel cell or bag tank) may be load carrying.

IC2.4.4 Any size fuel tank may be used.

IC2.4.5 The fuel system must have a provision for emptying the fuel tank if required.

IC2.4.6 The fuel tank, by design, must not have a variable capacity.

IC2.5 Fuel System Location Requirements

IC2.5.1 All parts of the fuel storage and supply system must lie within the surface defined by the top of the roll bar and the outside edge of the four tires. (See Figure 13). In side view no portion of the fuel system must project below the lower surface of the frame or the monocoque, whichever is applicable.

IC2.5.2 All fuel tanks must be shielded from side or rear impact collisions. Any fuel tank which is located laterally outside the Side Impact Structure must be shielded by structure built to T3.24 or T3.33. Any portion of the fuel system that is less than 350 mm (13.8 inches) above the ground, and all parts of the fuel tank, must be within the Primary Structure.

IC2.5.3 A firewall must be incorporated to separate the fuel tank from the driver, per Rule T4.5.

IC2.6 Fuel Tank Filler Neck & Sight Tube

IC2.6.1 All fuel tanks must have a filler neck which is:

- a. minimum 35 mm (1.375 inches) inner diameter at any point between the fuel tank and the fuel filler cap,
- b. minimum 125 mm (4.9 inches) vertical height
- c. angled at no more than thirty degrees (30°) from the vertical.

IC2.6.2 At least 125 mm (4.9 inches) vertical height of the fuel filler neck must be above the top level of the tank, and must be accompanied by a clear fuel resistant sight tube for reading the fuel level. (Figure 14)

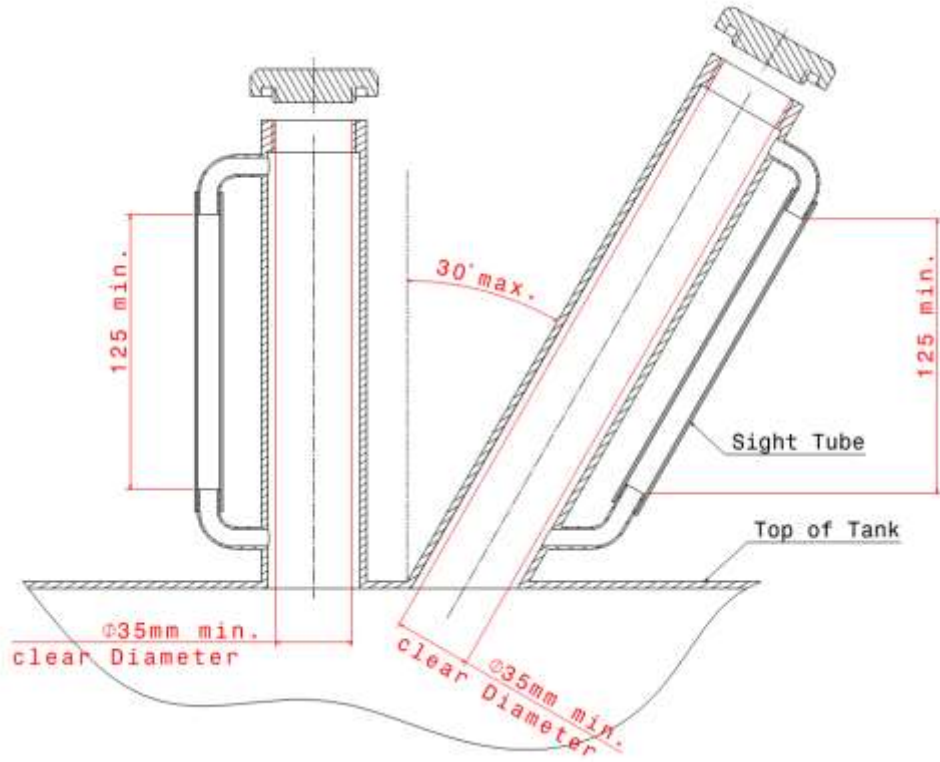

FIGURE 14



FIGURE 14A – not to scale

- IC2.6.3 The sight tube must have at least 125 mm (4.9 inches) of visible vertical height and a minimum inside diameter of 6 mm (0.25 inches).
- IC2.6.4 The sight tube must not run below the top surface of the fuel tank.
- IC2.6.5 A clear filler neck tube may be used as a sight tube, subject to approval by the Rules Committee or technical inspectors at the event.
- IC2.6.6 Fuel Level Line - A permanent, non-moveable fuel level line must be located between 12.7 mm and 25.4 mm (0.5 inch and 1 inch) below the top of the visible portion of the sight tube. This line will be used as the fill line for the Tilt Test (Rule T8.5), and before and after the Endurance Test to measure the amount of fuel used during the Endurance Event.
- IC2.6.7 The sight tube and fuel level line must be clearly visible to two individuals (one to fill the tank, the other to visually verify fill) without the need of assistance (e.g., artificial lighting, magnifiers) or the need to remove any parts (e.g., body panels).
- IC2.6.8 The individual filling the tank must be able to have complete direct access to the filler neck opening with a standard 2-gallon gas can assembly. (See Figure 14A for standard can dimension).
- IC2.6.9 The fill neck must have a fuel cap that can withstand severe vibrations or high pressures such as could occur during a vehicle rollover event

IC2.7 Tank Filling Requirement

- IC2.7.1 The fuel tank must be capable of being filled to capacity without manipulating the tank or the vehicle in any manner. The Fuel System must be designed in a way that during refueling of the car on a level surface, the formation of air cavities or other effects that cause the fuel level observed at the sight tube to drop after movement or operation of the car (other than due to consumption) is prevented. During fueling or refueling the vehicle may only be touched by the fuel crew and officials. The tank will be filled to the fill line, or if a filling system is used, to the automatic stop point. If, for any reason, the fuel level changes after the team have moved the vehicle, then no additional fuel will be added.
- IC2.7.2 The fuel system must be designed such that the spillage during refueling cannot contact the driver position, exhaust system, hot engine parts, or the ignition system.
- IC2.7.3 Belly pans must be vented to prevent accumulation of fuel. At least 2 holes, each of a minimum diameter of 25 mm, must be provided in the lowest part of the structure in such a way as to prevent accumulation of volatile liquids and/or vapours.

IC2.8 Venting Systems

- IC2.8.1 The fuel tank and carburetor venting systems must be designed such that fuel cannot spill during hard cornering or acceleration.
- IC2.8.2 All fuel vent lines must be equipped with a check valve to prevent fuel leakage when the tank is inverted. All fuel vent lines must exit outside the bodywork.

ARTICLE 3: EXHAUST SYSTEM AND NOISE CONTROL

IC3.1 Exhaust System General

IC3.1.1 Exhaust Outlet

The exhaust must be routed so that the driver is not subjected to fumes at any speed considering the draft of the car.

IC3.1.2 The exhaust outlet(s) must not extend more than 45 cm (17.7 inches) behind the centerline of the rear axle, and must be no more than 60 cm (23.6 inches) above the ground.

IC3.1.3 Any exhaust components (headers, mufflers, etc.) that protrude from the side of the body in front of the main roll hoop must be shielded to prevent contact by persons approaching the car or a driver exiting the car.

IC3.1.4 The application of fibrous/absorbent material, e.g. “header wrap”, to the outside of an exhaust manifold or exhaust system is prohibited.

IC3.2 Noise Measuring Procedure

IC3.2.1 The sound level will be measured during a static test. Measurements will be made with a free-field microphone placed free from obstructions at the exhaust outlet level, 0.5 m (19.68 inches) from the end of the exhaust outlet, at an angle of forty-five degrees (45°) with the outlet in the horizontal plane. The test will be run with the gearbox in neutral at the engine speed defined below. Where more than one exhaust outlet is present, the test will be repeated for each exhaust and the highest reading will be used.

IC3.2.2 The car must be compliant at all engine speeds up to the maximum test speed defined below.

IC3.2.3 If the exhaust has any form of active tuning or throttling device or system, it must be compliant with the device or system in all positions. Manually adjustable tuning devices must require tools to change and must not be moved or modified after the noise test is passed. The position of the device must be visible to the officials for the noise test and must be manually operable by the officials during the noise test.

IC3.2.4 Test Speeds

The maximum test speed for a given engine will be the engine speed that corresponds to an average piston speed of 914.4 m/min (3,000 ft. /min) for automotive or motorcycle engines, and 731.5 m/min (2,400 ft. /min) for “industrial engines”. The calculated speed will be rounded to the nearest 500 rpm. The test speeds for typical engines will be published by the organizers.

The idle test speed for a given engine will be up to the team and determined by their calibrated idle speed. If the idle speed varies then the car will be tested across the range of idle speeds determined by the team.

An “industrial engine” is defined as an engine which, according to the manufacturers’ specifications and without the required restrictor, is not capable of producing more than 5 hp per 100cc. To have an engine classified as “an industrial engine”, approval must be obtained from organizers prior to the Competition.

IC3.3 Maximum Sound Level

At idle the maximum permitted sound level is 103 dBC, fast weighting. At all other speeds the maximum permitted sound level is 110 dBC, fast weighting.

IC3.4 Noise Level Re-testing

At the option of the officials, noise may be measured at any time during the competition. If a car fails the noise test, it will be withheld from the competition until it has been modified and re-passes the noise test.

ARTICLE 4: ELECTRICAL SYSTEM AND SHUTDOWN SYSTEM

IC4.1 Master Switches

IC4.1.1 The vehicle must be equipped with two (2) master switches which form part of the shutdown system. Actuating either switch must stop the engine.

IC4.1.2 The international electrical symbol consisting of a red spark on a white-edged blue triangle must be affixed in close proximity to each switch.

Any alternator field wire must also be disabled by each master switch to prevent any possible feedback through the field coil circuit.

IC4.2 Primary Master Switch

IC4.2.1 The primary master switch must:

- Be located on the (driver's) right side of the vehicle, in proximity to the Main Hoop, at shoulder height and be easily actuated from outside the car.
- Disable power to ALL electrical circuits, including the battery, alternator, lights, fuel pump(s), ignition and electrical controls.
- All battery current must flow through this switch.
- Be of a rotary type and must be direct acting, i.e. it must not act through a relay.

An example of a typical switch that meets these requirements is shown below.



IC4.2.2 The master switches must be mounted so that the rotary axis of the key is near horizontal and across the car. The “ON” position of the switch must be in the horizontal position and must be marked accordingly. The “OFF” position of the primary master switch must also be clearly marked.

IC4.3 Cockpit-mounted Master Switch

IC4.3.1 The cockpit-mounted master switch:

- Must be located to provide easy actuation by the driver in an emergency or panic situation.
- Must be located within easy reach of the belted-in driver, alongside the steering wheel, and unobstructed by the steering wheel or any other part of the car. It is suggested that it be placed on the same side of the steering wheel as the shifter mechanism.
- Must be a push/pull Emergency switch with a minimum diameter of 24 mm. The switch must be installed such that:

- i. From the ON position, pushing on the switch will disable power to the ignition and all fuel pumps, and
- ii. From the OFF position, pulling on the switch will enable power to the ignition and fuel pump(s). Switches that require a twist or twist and pull to enable power are acceptable.
- d. May act through a relay.

Examples of typical switches that meet these requirements are shown below.



IC4.4 Batteries

IC4.4.1 All batteries, i.e. on-board power supplies, must be attached securely to the frame.

IC4.4.2 Any wet-cell battery located in the driver compartment must be enclosed in a nonconductive marine-type container or equivalent.

IC4.4.3 The hot (ungrounded) terminal must be insulated.

IC4.4.4 Battery packs based on Lithium Chemistry:

- a. Must have overcurrent protection that trips at or below the maximum specified discharge current of the cells.
- b. Must have a rigid, sturdy and fire retardant casing.
- c. Must be separated from the driver by a firewall as specified in T4.5

IC4.4.5 All batteries using chemistries other than lead acid must be presented at technical inspection with markings identifying it for comparison to a datasheet or other documentation proving the pack and supporting electronics meet all rules requirements

IC4.5 Brake-Over-Travel-Switch

The Brake-Over-Travel-Switch forms part of the shutdown system and as defined in T7.3 must remove power from the engine and fuel pumps.

IC4.6 Voltage limit for IC vehicles

The maximum permitted voltage between any two electrical connections is 60V DC or 25V AC RMS. The following systems are excluded from this voltage limit:

- a. High voltage systems for ignition
- b. High voltage systems for injectors
- c. Voltages internal to OEM charging systems designed for <60VDC output.

2017-18 FORMULA SAE RULES

PART EV - TECHNICAL REGULATIONS – ELECTRIC VEHICLES

The principle of the Electric Vehicle part is to allow the development of fully electric vehicles within the FSAE framework. These rules are based on the electric vehicle regulations developed by Formula Student and Formula Student Germany, and also include elements of the Formula Hybrid Rules.

ARTICLE 1: ELECTRIC SYSTEM DEFINITIONS

EV1.1 High-Voltage (HV) and Low-Voltage (LV)

EV1.1.1 Whenever a circuit has a potential difference where the nominal operation voltage is greater than 60V DC or 25V AC RMS it is defined as part of the High Voltage or tractive system.

EV1.1.2 The maximum permitted voltage that may occur between any two electrical connections is different between the competitions allowing electric vehicles. The following table lists the respective values:

Competition	Voltage Level
Formula SAE Electric	300 VDC
Formula SAE Brazil	300 VDC
Formula SAE Australasia	600 VDC
Formula SAE Italy	600 VDC
Formula Student	600 VDC
Formula Student Germany	600 VDC
Student Formula Japan	600 VDC

EV1.1.3 Low voltage is defined as any voltage below and including 60V DC or 25V AC RMS.

EV1.1.4 The tractive system accumulator is defined as all the battery cells or super-capacitors that store the electrical energy to be used by the tractive system.

EV1.1.5 Accumulator segments are sub-divisions of the accumulator and must respect either a maximum voltage or energy limit. Splitting the accumulator into its segments is intended to reduce the risks associated with working on the accumulator.

EV1.2 Grounded Low Voltage and Tractive System

EV1.2.1 The tractive system of the car is defined as every part that is electrically connected to the motor(s) and tractive system accumulators.

EV1.2.2 The grounded low voltage (GLV) system of the car is defined as every electrical part that is not part of the tractive system.

EV1.2.3 The tractive system must be completely isolated from the chassis and any other conductive parts of the car.

- EV1.2.4 The tractive-system is a high-voltage system by definition, see EV1.1.1.
- EV1.2.5 The GLV system must be a low-voltage-system, see EV1.1.3.
- EV1.2.6 The GLV system must be grounded to the chassis.
- EV1.2.7 The entire tractive and GLV system must be completely galvanically separated.
The border between tractive and GLV system is the galvanic isolation between both systems.
Therefore, some components, such as the motor controller, may be part of both systems.
- EV1.2.8 All components in the tractive system must be rated for the maximum tractive system voltage.
- EV1.2.9 The tractive system motor(s) must be connected to the accumulator through a motor controller.
Bypassing the control system and connecting the tractive batteries directly to the motor(s) is prohibited.
- EV1.2.10 The GLV system must be powered up using a specified procedure before it is possible to activate the tractive system, see EV4.10. Furthermore, a failure causing the GLV system to shut down must immediately deactivate the tractive system as well.

ARTICLE 2: ELECTRIC POWERTRAIN

EV2.1 Motors

- EV2.1.1 Only electrical motors are allowed. Any type of electrical motor is allowed. The number of motors is not limited.
- EV2.1.2 The rotating part of the motor must be contained within a structural casing where the thickness is at least 3.0 mm (0.120 inch) for Aluminum alloy 6061-T6 or 2.0 mm (0.080 inch) for steel. The motor casing may be the original motor casing, a team built motor casing or the original casing with additional material added to achieve the minimum required thickness. If lower grade Aluminum Alloy is used, then the material must be thicker to provide an equivalent strength.

NOTE: Use of a higher grade alloy does not enable a reduced thickness to be used.

- EV2.1.3 If the motor casing rotates around the stator, or the motor case is perforated, then a scatter shield must be included around the motor. This scatter shield must be at least 1.0mm (0.04 inch) thick and made from aluminum alloy 6061-T6 or steel.

EV2.2 Power and Voltage Limitation

- EV2.2.1 The maximum power drawn from the battery must not exceed 80kW. This will be checked by evaluating the Energy Meter data.
- EV2.2.2 The maximum voltage in the tractive system must not exceed the voltage defined in EV1.1.2. This will be checked by evaluating the Energy Meter data.
- EV2.2.3 Violating these values will lead to disqualification for the entire dynamic event in which the violation occurred e.g. if a violation occurs during one single acceleration run, the team will be disqualified for the complete acceleration event.

- EV2.2.4 A violation is defined as using more than 80kW or exceeding the specified voltage for more than 100ms continuously or using more than 80kW or exceeding the specified voltage, after a moving average over 500ms is applied.
- EV2.2.5 The respective data of each run in which a team has drawn more than 80kW from the battery or where the maximum permitted voltage is exceeded and the resulting decision will be made public.
- EV2.2.6 Non-availability of Energy Meter data due to the team's fault will be treated as a violation.
- EV2.2.7 Regenerating energy is allowed and unrestricted but only when the vehicle speed is > 5kph. It is not allowed at vehicle speeds <= 5kph.
- EV2.2.8 Supplying power to the motor such that the car is driven in reverse is prohibited.

EV2.3 Accelerator Pedal Position Sensor - APPS

- EV2.3.1 Drive-by-wire control of wheel torque is permitted.
- EV2.3.2 The APPS must be actuated by a foot pedal. Pedal travel is defined as percent of travel from a fully released position to a fully applied position where 0% is fully released and 100% is fully applied.
- EV2.3.3 The foot pedal must return to its original position when not actuated. The foot pedal must have a positive stop preventing the mounted sensors from being damaged or overstressed. Two springs must be used to return the foot pedal to the off position and each spring must be capable of returning the pedal to the fully released position with the other disconnected.

The springs in the APPS are not acceptable pedal return springs.

- EV2.3.4 At least two entirely separate sensors have to be used as APPSs. The sensors must have different transfer functions, each having a positive slope sense with either different gradients and/or offsets to the other(s).

NOTE: The intent of this rule is that in a short circuit the APPSs will only agree at 0% pedal position.

- EV2.3.5 If an implausibility occurs between the values of the APPSs and persists for more than 100msec, the power to the motor(s) must be immediately shut down completely. It is not necessary to completely deactivate the tractive system, the motor controller(s) shutting down the power to the motor(s) is sufficient.
- EV2.3.6 Implausibility is defined as a deviation of more than 10% pedal travel between the sensors or other failure as defined in EV2.3.9.
- EV2.3.7 If three sensors are used, then in the case of an APPS failure, any two sensors that agree within 10% pedal travel may be used to define the torque target and the 3rd APPS may be ignored.
- EV2.3.8 Each APPS must have a separate detachable connector that enables a check of these functions by unplugging it during Electrical Tech Inspection or else an inline switchable break-out box must be made available during Technical Inspection that allows disconnection of each APPS signal.
- EV2.3.9 The APPS signals must be sent directly to a controller using an analogue signal or via a digital data transmission bus such as CAN or FlexRay. Any failure of the APPS or APPS wiring must be detectable by the controller and must be treated like an implausibility, see EV2.3.5.

- EV2.3.10 When an analogue signal is used, e.g. from a 5V sensor, the APPS will be considered to have failed when they achieve an open circuit or short circuit condition which generates a signal outside of the normal operating range, for example $<0.5V$ or $>4.5V$. The circuitry used to evaluate the sensor will use pull down or pull up resistors to ensure that open circuit signals result in a failure being detected.
- EV2.3.11 When any kind of digital data transmission is used to transmit the APPS signal, the FMEA study must contain a detailed description of all the potential failure modes that can occur, the strategy that is used to detect these failures and the tests that have been conducted to prove that the detection strategy works. The failures to be considered must include but are not limited to the failure of the APPS, APPS signals being out of range, corruption of the message and loss of messages and the associated time outs.
- EV2.3.12 Any algorithm or electronic control unit that can manipulate the APPS signal, for example for vehicle dynamic functions such as traction control, may only lower the total driver requested torque and must never increase it. Thus the drive torque which is requested by the driver may never be exceeded.
- EV2.3.13 The current rules are written to only apply to the APPS (pedal), but the integrity of the torque command signal is important in all stages.
- EV2.4 Brake System Encoder - BSE**
- EV2.4.1 A brake system encoder or switch to measure brake pedal position or brake system pressure must be fitted to check for plausibility – see EV2.5
- EV2.4.2 The brake system encoder may be used to control regenerative braking
- EV2.4.3 The BSE must have a separate detachable connector that enables detection of error states and the response of the ECU to be checked by unplugging it during Electrical Tech Inspection, otherwise an inline switchable break-out box must be made available during technical inspection that allows disconnection of each BSE signal.
- EV2.4.4 The BSE or switch signals must be sent directly to a controller using an analogue signal or via a digital data transmission bus such as CAN or FlexRay. Any failure of the BSE or BSE wiring that persists more than 100 msec must be detectable by the controller and treated like an implausibility such that power to the motor(s) is immediately and completely shut down. It is not necessary to completely deactivate the tractive system, the motor controller(s) shutting down the power to the motor(s) is sufficient.
- EV2.4.5 When an analogue signal is used, e.g. from a 5V sensor, the BSE sensors will be considered to have failed when they achieve an open circuit or short circuit condition which generates a signal outside of the normal operating range, for example $<0.5V$ or $>4.5V$. The circuitry used to evaluate the sensor will use pull down or pull up resistors to ensure that open circuit signals result in a failure being detected.
- EV2.4.6 When any kind of digital data transmission is used to transmit the BSE signal, the FMEA study must contain a detailed description of all the potential failure modes that can occur, the strategy that is used to detect these failures and the tests that have been conducted to prove that the detection strategy works. The failures to be considered must include but are not limited to the failure of the sensor, sensor signals being out of range, corruption of the message and loss of messages and the associated time outs. In all cases a sensor failure must result in power to the motor(s) being immediately shutdown.

EV2.5 APPS / Brake Pedal Plausibility Check

The power to the motors must be immediately shut down completely, if the mechanical brakes are actuated and the APPS signals more than 25% pedal travel at the same time. This must be demonstrated when the motor controllers are under load.

- EV2.5.1 The motor power shut down must remain active until the APPS signals less than 5% pedal travel, no matter whether the brakes are still actuated or not.

ARTICLE 3: TRACTIVE SYSTEM - ENERGY STORAGE

EV3.1 Allowed Tractive System Accumulators

- EV3.1.1 All types of accumulators except molten salt and thermal batteries are allowed. E.g.: Batteries, Super-capacitors, etc. Fuel cells are prohibited.

- EV3.1.2 There are no concessions for using LiFePO₄ chemistry cells.

EV3.2 Tractive System Accumulator Container – General Requirements

- EV3.2.1 All cells or super-capacitors which store the tractive system energy will be built into accumulator segments and must be enclosed in (an) accumulator container(s).

- EV3.2.2 If spare accumulators are to be used then they all have to be of the same size, weight and type as those that are replaced. Spare accumulator packs have to be presented at Electrical Tech Inspection.

- EV3.2.3 If the accumulator container(s) is not easily accessible during Electrical Tech Inspection, detailed pictures of the internals taken during assembly have to be provided. However, at the end of the event the tech inspectors reserve the right to check any accumulators to ensure that the rules are adhered to.

- EV3.2.4 Each accumulator container must be removable from the car while still remaining rules compliant.

EV3.3 Tractive System Accumulator Container - Electrical Configuration

- EV3.3.1 If the container is made from an electrically conductive material, then the poles of the accumulator segment(s) and/or cells must be isolated from the inner wall of the accumulator container with an insulating material that is rated for the maximum tractive system voltage. All conductive surfaces on the outside of the container must have a low-resistance connection to the GLV system ground, see EV4.3. Special care must be taken to ensure that conductive penetrations, such as mounting hardware, are adequately protected against puncturing the insulating barrier.

- EV3.3.2 Every accumulator container must contain at least one fuse and at least two accumulator isolation relays, see EV3.5 and EV6.1.

- EV3.3.3 Maintenance plugs, additional contactors or similar measures have to be taken to allow electrical separation of the internal cell segments such that the separated cell segments contain a maximum static voltage of less than 120VDC and a maximum energy of 6MJ. The separation must affect both poles of the segment.

This separation method must be used whenever the accumulator containers are opened for maintenance and whenever accumulator segments are removed from the container.

It must not be physically possible to connect the Maintenance Plugs in any way other than the design intent configuration.

Maintenance plugs requiring tools to separate the segments will not be accepted.

Maintenance plugs must include a positive locking feature which prevents the plug from unintentionally becoming loose.

Maintenance plugs must be non-conductive on surfaces that do not provide any electrical connection.

- EV3.3.4 Each segment must be electrically insulated by the use of suitable material between the segments in the container and on top of the segment to prevent arc flashes caused by inter segment contact or by parts/tools accidentally falling into the container during maintenance for example. Air is not considered to be a suitable insulation material in this case.
- EV3.3.5 The Accumulator Isolation Relays (AIRs) and the main fuse must be separated with an electrically insulated and fireproof material to UL94-V0 from the rest of the accumulator. Air is not considered to be a suitable insulation material in this case.
- EV3.3.6 If the tractive system connectors to the accumulator containers can be removed without the use of tools, then a pilot contact/interlock line must be implemented which activates the shutdown circuit and opens the AIRs whenever the connector is removed.
- EV3.3.7 Contacting / interconnecting the single cells by soldering in the high current path is prohibited. Soldering wires to cells for the voltage monitoring input of the AMS is allowed, since these wires are not part of the high current path.
- EV3.3.8 Every wire used in an accumulator container, no matter whether it is part of the GLV or tractive system, must be rated to the maximum tractive system voltage.
- EV3.3.9 Each accumulator container must have a prominent indicator, such as an LED that will illuminate whenever a voltage greater than 60V DC is present at the vehicle side of the AIRs.
- EV3.3.10 The voltage being present at the connectors must directly control the indicator using hard wired electronics (no software control is permitted). Activating the indicator with the control signal which closes the AIRs is not sufficient.
- EV3.3.11 The accumulator voltage indicator must always work, e.g. even if the container is disconnected from the GLVS or removed from the car and carried around.

EV3.4 Tractive System Accumulator Container - Mechanical Configuration

- EV3.4.1 All accumulator containers must lie within the Primary Structure of the Frame (see T3.3).
- EV3.4.2 The accumulator container must be built of mechanically robust material.
- EV3.4.3 The container material must be fire resistant according to UL94-V0, FAR25 or equivalent.
- EV3.4.4 All accumulator containers must be protected from side or rear impact collisions by structure equivalent to that defined in T3.4 and must be included in the SES. **NOTE:** The container must not form part of the equivalent structure.
- EV3.4.5 All accumulator containers must be designed to withstand forces from deceleration. Teams have the option to use the design guidelines in rule EV3.4.6 or analyze the accumulator through the “Alternative Frame Rules” process. Design of the Accumulator container must be documented in the

SES or SRCF. Documentation includes materials used, drawings/images, fastener locations, cell/segment weight and cell/segment position.

EV3.4.6 Accumulator containers must be constructed of sheet/plate steel or aluminum in the following configuration:

- a. The floor or bottom of the accumulator container must be constructed of steel 1.25mm (0.049 inch) thick or aluminum 3.2mm (0.125 inch) thick.
- b. The external vertical walls must be constructed of steel 0.9mm (0.035 inch) thick or aluminum 2.3mm (0.09 inch) thick.
- c. Internal vertical walls separating cells and/or segments must be a minimum of 75 percent of the height of the external vertical walls and must be constructed of steel 0.9mm (0.035 inch) thick or aluminum 2.3mm (0.090 inch) thick.
- d. Covers and lids must be constructed of steel 0.9mm (0.035 inch) thick or aluminum 2.3mm (0.09 inch) thick.
- e. The floor and walls of the accumulator container must be joined by welds and/or fasteners. Any fasteners must be 6 mm Metric Grade 8.8 (1/4 inch SAE Grade 5) fasteners, or stronger.
- f. Internal vertical walls divide the accumulator container into “sections”. A maximum of 12kg (26.5 lbs.) is allowed in any section of the accumulator container.
 - i. Fastened connections between the floor and any vertical wall of each section must have at least 2 fasteners.
 - ii. Fastened connections between internal vertical walls and external vertical walls must be located in the top half of the internal vertical wall.
 - iii. Sections containing 8 kg (18 lbs) or less must have a minimum of 2 fasteners connecting any two vertical walls.
 - iv. Sections containing between 8 kg (18 lbs.) and 12 kg (26.5 lbs.) must have a minimum of 3 fasteners connecting any two vertical walls.

Example: An accumulator container with 2 internal walls has 3 sections. Each section contains less than 8 kb (18 lbs). Therefore 18 floor to wall joints are required in total with at least 2 fasteners per joint.

- g. Folding or bending plate material to create flanges or to eliminate joints between walls is acceptable.
- h. Covers and Lids must be fastened with a minimum of one fastener for each external vertical wall per section.
- i. Alternate materials are allowed with proof of equivalency per rule T3.31. Proof of equivalency must be documented in the SES and test samples must be available at technical inspection.
- j. Substituting one 6 mm (1/4 inch) bolt with two 5 mm (#12) bolts or three 4 mm (#10) bolts is allowed.

NOTE 1: An Example of an Accumulator complying with the design guidelines is available in the FAQs at <http://fsaeonline.com/>.

NOTE 2: The accumulator design guidelines are intended to generate a structure that does not fail under the following accelerations:

- a. 40g in the longitudinal direction (forward/aft)
- b. 40g in the lateral direction (left/right)
- c. 20g in the vertical direction (up/down)

EV3.4.7 The cells and/or segments must be appropriately secured against moving inside the container.

This mounting system must be designed to withstand the following accelerations:

- a. 40g in the longitudinal direction (forward/aft)
- b. 40g in the lateral direction (left/right)
- c. 20g in the vertical direction (up/down)

Calculations and/or tests proving these requirements are met must be included in the SES or SRCF. Any fasteners must be 6mm Metric Grade 8.8 (1/4 in SAE Grade 5) or stronger.

EV3.4.8 Accumulator containers must be attached to the major structure of the chassis

- a. The number of attachment points that must be used depends on the total weight of the container:

Accumulator Weight	Minimum Attachment Points
< 20 kg	4
20 – 30 kg	6
30 – 40 kg	8
> 40 kg	10

- b. Any brackets must be made of steel 1.6mm (0.063 inch) thick or aluminum 4mm (0.157 inch) thick and must have gussets to carry bending loads.
- c. Each attachment point, including any brackets, backing plates and inserts, must:
 - i. Be able to withstand 20kN in any direction
 - ii. Use at least one 8 mm Metric Grade 8.8 (5/16-inch Grade 5) fastener, or stronger.
- d. Composite monocoque chassis and/or accumulator containers must satisfy the following requirements:
 - i. Data obtained from the laminate perimeter shear strength and 3-point bending tests (T3.30) must be used for any strength calculations.
 - ii. Each attachment point requires steel backing plates with a minimum thickness of 2 mm. Alternate materials may be used for backing plates if equivalency is approved.
 - iii. The calculations and physical test results must be included in the SES or SRCF.

EV3.4.9 The Accumulator containers and mounting systems are subject to approval of the Chief Technical Inspector or their representative.

EV3.4.10 The accumulator segments contained within the accumulator must be separated by an electrically insulating and be fire resistant barrier (according to UL94-V0, FAR25 or equivalent) and must subdivide the accumulator into 6MJ segments if this is not already met by the separation due to the 120VDC voltage limit.

The contained energy of a stack is calculated by multiplying the maximum stack voltage with the nominal capacity of the used cell(s). Documentation of segment separation must be provided in the ESF.

EV3.4.11 Holes, both internal and external, in the container are only allowed for the wiring-harness, ventilation, cooling or fasteners. External holes must be sealed according to EV4.5.

EV3.4.12 The container must be completely closed at all times, when mounted to the car and also when dismantled from the car without the need to install extra protective covers. Openings for ventilation should be of a reasonable size, e.g. completely open sidepods containing accumulators are not allowed.

EV3.4.13 A sticker with an area of at least 750 mm² and a red or black lightning bolt on yellow background or red lightning bolt on white background must be applied on every accumulator container. The sticker must also contain the text “High Voltage” or something similar.

EV3.4.14 Any accumulators that may vent an explosive gas must have a ventilation system or pressure relief valve to prevent the vented gas from reaching an explosive concentration.

EV3.4.15 Every accumulator container which is completely sealed must also have a pressure relief valve to prevent high-pressure in the container.

EV3.5 Accumulator Isolation Relay(s) (AIR)

EV3.5.1 In every accumulator container at least two isolation relays must be installed.

EV3.5.2 The accumulator isolation relays must open both (!) poles of the accumulator. If these relays are open, no HV may be present outside of the accumulator container.

EV3.5.3 The isolation relays must be of a “normally open” type.

EV3.5.4 The fuse protecting the accumulator tractive system circuit must have a rating lower than the maximum switch off current of the isolation relays.

EV3.5.5 The accumulator isolation relays must not contain mercury.

EV3.6 Accumulator Management System (AMS)

EV3.6.1 Each accumulator must be monitored by an accumulator management system whenever the tractive system is active or the accumulator is connected to a charger. For battery systems this is generally referred to as a battery management system (BMS) however alternative electrical energy storage systems are allowed and therefore AMS will be the terminology used in this document.

EV3.6.2 The AMS must continuously measure the cell voltage of every cell, in order to keep the cells inside the allowed minimum and maximum cell voltage levels stated in the cell data sheet. If single cells are directly connected in parallel, only one voltage measurement is needed.

EV3.6.3 The AMS must continuously measure the temperatures of critical points of the accumulator to keep the cells below the allowed maximum cell temperature limit stated in the cell data sheet or below 60°C, whichever is lower.

Cell temperature must be measured at the negative terminal of the respective cell and the sensor used must be in direct contact with either the negative terminal or its busbar. If the sensor is on the busbar, it must be less than 10mm away from the cell terminal.

NOTE: A competition may use a special device to check the conformance to the temperature limits. Please check the website of the respective competition for further information.

EV3.6.4 For centralized AMS systems (two or more cells per AMS board), all voltage sense wires to the AMS must be protected by ‘fusible link wires’ or fuses so that any the sense wiring cannot exceed its current carrying capacity in the event of a short circuit. The fusing must occur in the conductor, wire or pcb trace which is directly connected to the cell tab.

Any distributed AMS system (one cell measurement per board) where the sense wire connections at the board are <25mm does not need additional fusing if the board is protected from short circuit and

the connection to the AMS is also protected. If these conditions are not met, then the positive cell terminal must be protected with a fusible link wire.

Where required, the fusible link wire may form the entire sense wire or a section of the sense wire. If the fusible link wire forms a section of the sense wire, then the gauge of the fusible link wire must be sized appropriately to protect the remaining part of the voltage sense wire from currents above its continuous current rating. If any of these fusible link wires are blown or if the connection to measure the cell voltage is interrupted in any other way, then this must be detected by the AMS and must be reported as a critical voltage problem.

NOTE 1: If a ‘fusible link wire’ is required and the resistance of the connection from the AMS board to the cell for the voltage measurement is too high, then this can affect the AMS voltage measurement especially during cell balancing and charging, therefore an appropriately large gauge wire must be used.

NOTE 2: A fusible link wire works such that when an over current event occurs, the conductor within the link is melted while the ensuing flame and spark is contained within the link's insulation. Specific products can be purchased which perform this function.

EV3.6.5 Any GLV connection to the AMS must be galvanically isolated from the tractive system.

EV3.6.6 For lithium based cells the temperature of at least 30% of the cells must be monitored by the AMS. The monitored cells have to be equally distributed within the accumulator container(s).

It is acceptable to monitor multiple cells with one sensor, if EV3.6.3 is met for all cells sensed by the sensor.

NOTE: It is strongly recommended to monitor every cell temperature.

EV3.6.7 The AMS must shutdown the tractive system by opening the AIRs, if critical voltage or temperature values according to the cell manufacturer's datasheet and taking into account the accuracy of the measurement system are detected. If the AMS does perform a shutdown, then a red LED marked AMS must light up in the cockpit to confirm this.

EV3.7 Grounded Low Voltage System (<=60V DC)

EV3.7.1 All GLV batteries, i.e. on-board power supplies, must be attached securely to the frame.

EV3.7.2 Any wet-cell battery located in the driver compartment must be enclosed in a nonconductive marine-type container or equivalent.

EV3.7.3 The hot (ungrounded) terminal must be insulated.

EV3.7.4 GLV battery packs must comply with IC4.4.4

ARTICLE 4: TRACTIVE SYSTEM – GENERAL REQUIREMENTS

EV4.1 Separation of Traction System and Grounded Low Voltage System

EV4.1.1 The layout of electrical devices designed by the team must be documented accurately in the ESF.

- EV4.1.2 There must be no connection between the frame of the vehicle (or any other conductive surface that might be inadvertently touched by a crew member or spectator), and any part of any tractive system circuits.
- EV4.1.3 Tractive system and GLV circuits must be physically segregated such that they are not run through the same conduit or connector, except for interlock circuit connections.
- EV4.1.4 GLV systems must not be included in the accumulator container except for required purposes. Exceptions include the AIRs, HV DC/CD converters, the AMS and the IMD. The galvanic isolation of any LV wiring within the accumulator container, and where appropriate elsewhere, must be described within the ESF.
- EV4.1.5 Where both tractive system and GLV are present within an enclosure, they must be separated by insulating barriers made of moisture resistant, UL recognized or equivalent insulating materials rated for 150 C or higher (e.g. Nomex based electrical insulation), or maintain the following spacing through air, or over a surface (similar to those defined in UL1741):
- $U < 100\text{VDC}$ 10 mm (0.4 inch)
 - $100\text{VDC} < U < 200\text{VDC}$ 20 mm (0.75 inch)
 - $U > 200\text{VDC}$ 30 mm (1.2 inch)
- EV4.1.6 Spacing must be clearly defined. Components and cables capable of movement must be positively restrained to maintain spacing.
- EV4.1.7 If tractive system and GLV are on the same circuit board, they must be on separate, clearly defined areas of the board. Furthermore, the tractive system and GLV areas have to be clearly marked on the PCB.

NOTE: The following spacing is related to the spacing between traces / board areas. If integrated circuits are used such as opto-couplers which are rated for the respective maximum tractive system voltage, but do not fulfill the required spacing, then they may still be used and the given spacing do not apply.

Required spacing are as follows:

Voltage	Over Surface	Thru Air (Cut in board)	Under Coating
0-50VDC	1.6 mm (1/16")	1.6 mm (1/16")	1 mm
50-150VDC	6.4 mm (1/4")	3.2 mm (1/8")	2 mm
150-300VDC	9.5 mm (3/8")	6.4 mm (1/4")	3 mm
300-600VDC	12.7 mm (1/2")	9.5 mm (3/8")	4 mm

- EV4.1.8 Teams must be prepared to demonstrate spacing on team-built equipment. Information on this must be included in the electrical system form (EV9.1). For inaccessible circuitry, spare boards or appropriate photographs must be available for inspection.
- EV4.1.9 All connections to external devices such as laptops from a tractive system component must include galvanic isolation.

EV4.2 Positioning of tractive system parts

- EV4.2.1 Except as allowed by EV4.2.3, all parts belonging to the tractive system including cables and wiring must be contained within the envelope of any part of the frame which is made from any regulated tubing defined in T3.4 and/or an additional envelope of tubing which meets the minimum specification defined in T3.4 or equivalent, such that they are protected against being damaged in case of a crash or roll-over situation.
- EV4.2.2 If tractive system parts are mounted in a position where damage could occur from a rear or side impact (below 350mm from the ground), for example motors at the rear of the car, they have to be protected by a fully triangulated structure with tubes of a minimum outer diameter of 25.4mm and a minimum wall thickness of 1.25mm or equivalent – see T3.4.
- EV4.2.3 Outboard wheel motors are allowed where the motor, attendant cables and wiring are outside of the frame but only if an interlock is added such that the shutdown circuit, EV5.1, is activated and the AIRs are opened if the wheel assembly is damaged or knocked off the car.
- EV4.2.4 In side or front view no part of the tractive-system must project below the lower surface of the frame or the monocoque, whichever is applicable.
- EV4.2.5 Additional regulations apply for accumulators, see EV3.4.

EV4.3 Grounding

- EV4.3.1 All electrically conductive parts of the vehicle (e.g. parts made of steel, (anodized) aluminum, any other metal parts, etc.) which are within 100mm of any tractive system or GLV component, and any driver harness mounting points, seat mounting points and driver controls must have a resistance below 300 mOhms (measured with a current of 1A) to GLV system ground.
- EV4.3.2 All parts of the vehicle which may become electrically conductive (e.g. completely coated metal parts, carbon fiber parts, etc.) which are within 100mm of any tractive system or GLV component, must have a resistance below 5 Ohm to GLV system ground.
- EV4.3.3 Electrical conductivity of any part may be tested by checking any point which is likely to be conductive, for example the driver's harness attachment bolt, but where no convenient conductive point is available then an area of coating may be removed.

NOTE: Carbon fiber parts may need special measures such as using copper mesh or similar to keep the ground resistance below 5 Ohms.

EV4.4 Tractive System Measuring points (TSMP)

- EV4.4.1 Two tractive system voltage measuring points must be installed directly next to the master switches, see EV5.2.
- EV4.4.2 The TSMPs must be protected by a non-conductive housing that can be opened without tools.
- EV4.4.3 The TSMP must be protected from being touched with bare hands / fingers, once the housing is opened.
- EV4.4.4 4mm shrouded banana jacks rated to an appropriate voltage level must be used for the TSMPs, see the picture below for an example.



- EV4.4.5 The TSMPs must be connected to the positive and negative motor controller/inverter supply lines and must be marked HV+ and HV-
- EV4.4.6 Each TSMP must be secured with a current limiting resistor according to the following table. Fusing of the TS measuring points is prohibited. Teams must ensure it is possible to directly measure the value of the resistor during Electrical Tech Inspection.

Maximum TS Voltage	Resistor Value
$U_{max} \leq 200\text{VDC}$	5kR
$200\text{VDC} < U_{max} \leq 400\text{VDC}$	10kR
$400\text{VDC} < U_{max} \leq 600\text{VDC}$	15kR

- EV4.4.7 The TSMPs will be used to check during Electrical Tech Inspection that the tractive system is shut down properly in the given time, see EV5.1.3. They are also needed to ensure the isolation of the tractive system of the vehicle for possible rescue operations after an accident or when work on the vehicle is to be done.
- EV4.4.8 Next to the TSMP a GLV system ground measuring point must be installed. This measuring point must be connected to GLV system ground and must be marked GND.
- EV4.4.9 A 4mm shrouded banana jack must be used for the GLV ground measuring point; see the picture below for an example.



EV4.5 Tractive System Insulation, wiring and conduit

- EV4.5.1 All parts, especially live wires, contacts, etc. of the tractive system must be isolated by non-conductive material or covers to be protected from being touched. In order to achieve this, it must not be possible to touch any tractive system connections with a 100 mm long, 6 mm diameter (4 x ¼ inch) insulated test probe when the tractive system enclosures are in place.
- EV4.5.2 Non-conductive covers must prevent inadvertent human contact with any tractive system voltage. This must include crew members working on or inside the vehicle. Covers must be secure and adequately rigid. Body panels that must be removed to access other components, etc. are not a substitute for enclosing tractive system connections.
- EV4.5.3 Tractive system components and containers must be protected from moisture in the form of rain or puddles.

NOTE: A rating of IP65 is recommended for the rain test.

EV4.5.4 Insulation material that is appropriate for the expected surrounding temperatures must be used and this must have a minimum temperature rating of 90°C. Using only insulating tape or rubber-like paint for insulation is prohibited.

EV4.5.5 All wires and terminals and other conductors used in the tractive system must be sized appropriately for the continuous tractive system current and the wires must be marked with wire gauge, temperature rating and insulation voltage rating. Alternatively, a serial number or a norm printed on the wire is sufficient if this serial number or norm is clearly bound to the wire characteristics for example by a data sheet. The minimum acceptable temperature rating for tractive system cables is 90°C.

NOTE: Sizing of the conductors for the ‘continuous tractive system current’ may take account of the RMS or average electrical current that will be used and the anticipated duration of time at maximum electrical current.

EV4.5.6 All tractive system wiring must be done to professional standards with appropriately sized conductors and terminals and with adequate strain relief and protection from loosening due to vibration etc.

EV4.5.7 All tractive system wiring that runs outside of electrical enclosures must either be enclosed in separate orange non-conductive conduit or use an orange shielded cable. Except in the case where the tractive system wiring runs in a fully enclosed container, the conduit or shielded cable must be securely anchored at least at each end so that it can withstand a force of 200N without straining the cable end crimp, and must be located out of the way of possible snagging or damage. Body work is not sufficient to meet this enclosure requirement. Any shielded cable must have the shield grounded.

EV4.5.8 All tractive system connections must be designed so that they use intentional current paths through conductors such as copper or aluminum and should not rely on steel bolts to be the primary conductor. The connections must not include compressible material such as plastic in the stack-up.

EV4.5.9 Tractive system wiring must be shielded against damage by rotating and / or moving parts.

EV4.5.10 If external, un-insulated heat sinks are used, they must be properly grounded to the GLV System ground, see EV4.3.

EV4.5.11 Wiring that is not part of the tractive system must not use orange wiring or conduit.

EV4.5.12 All electrical connections, including bolts, nuts, and other fasteners, in the high current path of the tractive system must be secured from unintentional loosening by the use of positive locking mechanisms that are suitable for high temperatures, for example torque prevailing nuts. For some applications, for example AIRs, it is possible that locking helicoils or similar need to be used. In the case that a locking helicoil or an approved positive locking mechanism is required that cannot easily be inspected at electrical technical inspection, information about this item must be included in the ESF.

It is also allowed to construct custom locking features that prevent fasteners from coming loose as long as they can be seen to be in place and do not rely on the clamping force for the locking feature.

Lock washers and thread locking compounds, e.g. Loctite®, DO NOT meet the positive locking requirement and Nyloc nuts do not meet the temperature requirements.

EV4.6 Tractive System Enclosures

- EV4.6.1 Every housing or enclosure containing parts of the tractive system, except motor housings, must be labeled with (a) reasonably sized sticker(s) with a red or black lightning bolt on yellow background or red lightning bolt on white background. The sticker must also contain the text “High Voltage” or something similar if the voltage is more than 60V DC or 25VAC.
- EV4.6.2 If the housing material is electrically conductive or possibly electrically conductive, it must have a low-resistance connection to GLV system ground, see EV4.3.

EV4.7 HV Disconnect (HVD)

- EV4.7.1 It must be possible to disconnect at least one pole of the tractive system accumulator by quickly removing an unobstructed and directly accessible element, fuse or connector, in case of (a) stuck accumulator isolation relay(s) for example. It must be possible to disconnect the HVD without removing any bodywork. The HVD must be above 350mm from the ground and easily visible when standing behind the vehicle. Remote actuation of the HVD through a long handle, rope or wire is not acceptable.
- EV4.7.2 An untrained person must be able to remove the HVD within 10 seconds in ready-to-race condition. This will be tested during Electrical Tech Inspection. Being able to quickly disconnect the accumulator(s) from the rest of the tractive system by its connector(s) will satisfy this rule.
- EV4.7.3 EV4.5 remains valid, therefore a dummy connector or similar may be needed to restore the system's isolation.
- EV4.7.4 The HV Disconnect must be clearly marked with "HVD".
- EV4.7.5 No tools must be needed to open the HVD. Therefore, an interlock must activate the shutdown circuit and open the AIRs when the HVD is removed.

EV4.8 Wiring of the tractive system supply

- EV4.8.1 All accumulator containers must be wired to a single point. It does not matter if they are wired in series or parallel, but all the power supplying the tractive system must flow through this single point and must pass the energy meter position, see EV4.9.
- EV4.8.2 No further energy storages except for reasonably sized intermediate circuit capacitors are allowed beyond this point.

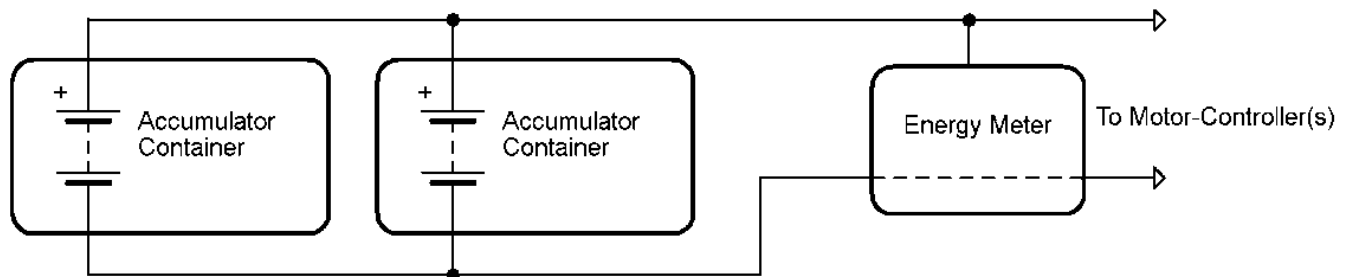

EV4.9 Energy meter

- EV4.9.1 In the tractive system supply wires, see EV4.8, a calibrated energy meter must be inserted at the competition. The energy meter is used to calculate the efficiency score by measuring the total energy being sourced by the accumulator(s).

- EV4.9.2 The energy meter is sealed by the officials before the dynamic events. Any manipulation or broken seals of the energy meter result in at least a DNF for the efficiency scoring.
- EV4.9.3 The energy meter must be in an easily accessible location so that the recorded data can be quickly downloaded by the officials after the Endurance Event to calculate the efficiency score.
- EV4.9.4 The energy is calculated as the time integrated value of the measured voltage multiplied by the measured current logged by the Energy Meter.

EV4.10 Activating the Tractive System

- EV4.10.1 The driver must be able to (re-)activate or reset the tractive system from within the cockpit without the assistance of any other person except for situations in which the AMS, IMD or BSPD have shut down the tractive system, see EV5.1.4 and EV5.1.5.
- EV4.10.2 Closing only the shutdown circuit must not set the car to ready-to-drive mode. The car is ready to drive as soon as the motor(s) will respond to the input of the APPS. Therefore, additional actions are required by the driver to set the car to ready-to-drive-mode e.g. pressing a dedicated start button, after the tractive system has been activated. One of these actions must include the brake pedal being pressed as ready-to-drive-mode is entered.

EV4.11 Pre-Charge and Discharge Circuits

- EV4.11.1 A circuit that is able to pre-charge the intermediate circuit to at least 90% of the current accumulator voltage before closing the second AIR must be implemented. This circuit must be disabled by a de-activated shutdown circuit, see EV5.1. Therefore, the pre-charge circuit must not be able to pre-charge the system, if the shutdown circuit is open.
- EV4.11.2 Any pre-charge circuitry must be supplied directly from the TSMS
- EV4.11.3 It is allowed to pre-charge the intermediate circuit for a conservatively calculated time, before closing the second AIR. A feedback via measuring the current intermediate circuit voltage is not required.
- EV4.11.4 If a discharge circuit is needed to meet EV5.1.3, it must be designed to handle the maximum discharge current for at least 15 seconds. The calculation proving this must be part of the ESF.
- EV4.11.5 The discharge circuit must be wired in a way that it is always active whenever the shutdown circuit is open. Furthermore, the discharge circuit must be fail-safe such that it still discharges the intermediate circuit capacitors if the HVD has been opened.
- EV4.11.6 Fusing of the precharge and discharge circuits is prohibited.

EV4.12 Tractive System Active Light (TSAL)

- EV4.12.1 The vehicles must include a single Tractive Systems Active Light (TSAL) that must illuminate when the voltage outside the accumulator container(s) exceeds 60V DC or 25V AC RMS. The TSAL must not perform any other functions.
- EV4.12.2 The TSAL itself must:
 - a. Be directly controlled by the voltage present within the tractive system using hard wired electronics. Software control is not permitted.
 - b. Be red in color.
 - c. Flash continuously with a frequency between 2Hz and 5Hz when illuminated.

EV4.12.3 The TSAL mounting location must:

- a. Be near the main roll hoop at the highest point of the vehicle.
- b. Be mounted lower than the highest point of the main roll hoop.
- c. Be no lower than 150 mm from the highest point of the roll hoop.
- d. Not allow contact with the driver's helmet in any circumstances.
- e. Not be in proximity to other lights.

EV4.12.4 The TSAL must be visible:

- a. From every horizontal direction, except small angles which are blocked by the main roll hoop.
- b. From a point 1.6m vertically from ground level, within a 3m horizontal radius from the TSAL.
- c. In direct sunlight.

EV4.13 Ready-To-Drive-Sound

EV4.13.1 The car must make a characteristic sound, continuously for at least 1 second and a maximum of 3 seconds when it is ready to drive.

EV4.13.2 The car is ready to drive as soon as the motor(s) will respond to the input of the APPS.

EV4.13.3 The sound level must be a minimum of 80dBA, fast weighting. The sound level will be measured with a free-field microphone placed free from obstructions in a radius of 2m around the car.

EV4.13.4 The used sound must be easily recognizable. No animal voices, song parts or sounds that could be interpreted as offensive will be accepted.

EV4.13.5 The vehicle must not make sounds similar to the ready to drive sound.

ARTICLE 5: SHUTDOWN CIRCUIT AND SYSTEMS

EV5.1 Shutdown Circuit

EV5.1.1 The shutdown circuit directly carries the current driving the accumulator isolation relays (AIRs).

EV5.1.2 The shutdown circuit consists of at least 2 master switches, 3 shut-down buttons, the brake-over-travel-switch, the insulation monitoring device (IMD), the inertia switch, the brake system plausibility device, all required interlocks and the accumulator management system (AMS).

EV5.1.3 If the shutdown circuit is opened/interrupted the tractive system must be shutdown by opening all accumulator isolation relay(s) and the voltage in the tractive system must drop to under 60V DC or 25V AC RMS in less than five seconds after opening the shutdown circuit. All accumulator current flow must stop immediately.

An explanatory schematic of the required shutdown circuit, excluding possibly needed interlock circuitry, is shown below.

Cell balancing when the accumulator isolation relays are open is not permitted.

EV5.1.4 If the shutdown circuit is opened by the AMS, the IMD or the BSPD the tractive system must remain disabled until being manually reset by a person directly at the car which is not the driver. Remote reset, for example via WLAN or use of the three shutdown buttons or the TS master switch to reset the AMS, IMD or BSPD is not permitted.

EV5.1.5 It must not be possible for the driver to re-activate the tractive system from within the car in case of an AMS, IMD or BSPD fault.

For example: Applying an IMD test resistor between HV+ and GLV system ground must deactivate the system. Disconnecting the test resistor must not re-activate the system. The tractive system must remain inactive until it is manually reset.

EV5.1.6 All circuits that are part of the shutdown circuit must be designed in a way, that in the de-energized/disconnected state they are open such that each circuit will remove the current controlling the AIRs.

EV5.1.7 If the tractive system is de-activated while driving, the motor(s) has/have to spin free e.g. no brake torque must be applied to the motor(s).

EV5.1.8 In order to offer additional protection to the AIRs, it is allowed to use a capacitor to hold the AIRs closed for up to 250ms after removing the current source that keeps them closed, such that the motor controller has some opportunity to reduce the tractive current before the AIRs isolate the accumulator from the rest of the tractive system.

EV5.1.9 It must be possible to demonstrate that all features of the Shutdown circuit function correctly. It should be noted that this includes all interlocks.

EV5.1.10 Every system required or able to open the shut-down circuit must have its own, non-programmable power stage to achieve this. The respective power stages must be designed such that a failure cannot result in electrical power being fed back into the electrical shutdown circuit.

EV5.1.11 The Shutdown buttons, the brake over travel switch, the TSMS and all interlocks must not act through any power stage, but must directly carry the AIR current.

EV5.2 Master Switches

EV5.2.1 Each vehicle must have two Master Switches, the Grounded Low Voltage Master Switch (GLVMS) and the Tractive System Master Switch (TSMS).

EV5.2.2 The GLVMS must completely disable power to the GLV System and must be direct acting, i.e. it must not act through a relay or logic.

EV5.2.3 The GLVMS must be located on the right side of the vehicle, in proximity to the Main Hoop, at the driver's shoulder height and be easily actuated from outside the car.

EV5.2.4 The TSMS must be located next to the GLVMS and must open the shutdown circuit. The TSMS must be direct acting, i.e. it cannot act through a relay or logic, and must be the last switch before the AIRs except for pre-charge circuitry and hardwired interlocks. Interlocks between the TSMS and AIR's must not be in the low (ground) connection to the AIR coils.

EV5.2.5 The TSMS must be fitted with a "lockout/tagout" capability to prevent accidental activation of the tractive system. The electrical system officer must ensure that the TSMS is locked in the off position whenever work is done on the vehicle.

EV5.2.6 Both master switches must be of the rotary type, with a red, removable key, similar to the one shown in the explanatory shutdown circuit.

- EV5.2.7 The master switches must not to be easily removable, e.g. they must not be mounted onto removable body work.
- EV5.2.8 The function of both switches must be clearly marked with “LV” and “HV”. A sticker with a red or black lightning bolt on a yellow background or red lightning bolt on a white background must additionally mark the Tractive System Master Switch.
- EV5.2.9 Both master switches must be mounted so that the rotary axis of the key is near horizontal and across the car. The “ON” position of both switches must be in the horizontal position and must be marked accordingly. The “OFF” position of both switches must also be clearly marked.

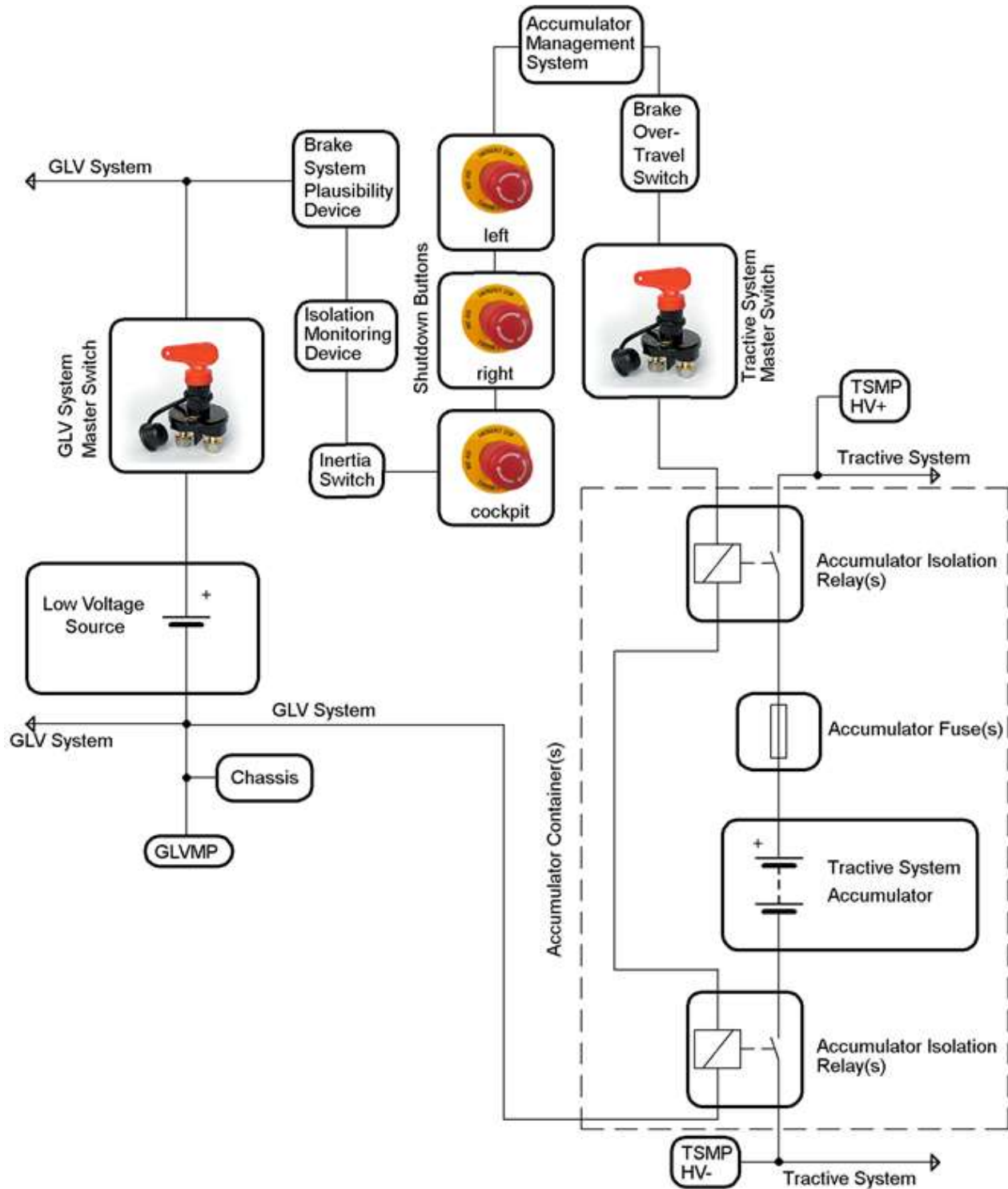

EV5.3 Shutdown Buttons

EV5.3.1 A system of three shut-down buttons must be installed on the vehicle.

EV5.3.2 Pressing any one of the shut-down buttons must separate the tractive system from the accumulator block by opening the shutdown circuit, see also EV5.1.

- EV5.3.3 Each shut-down button must be a push-pull or push-rotate emergency switch where pushing the button opens the shutdown circuit. The shut-down buttons must not act through programmable logic.
- EV5.3.4 One button must be located on each side of the vehicle behind the driver's compartment at approximately the level of the driver's head. The minimum allowed diameter of the shutdown buttons on both sides of the car is 40 mm. The international electrical symbol consisting of a red spark on a white-edged blue triangle must be affixed in close proximity to this button.
- EV5.3.5 One shutdown button serves as a cockpit-mounted Master Switch. The minimum allowed diameter of the shutdown button in the cockpit is 24 mm. The international electrical symbol consisting of a red spark on a white-edged blue triangle must be affixed in close proximity to this switch. It must be located to provide easy actuation by the driver in an emergency or panic situation. It must be located within easy reach of the belted-in driver, alongside the steering wheel, and unobstructed by the steering wheel or any other part of the car.
- EV5.3.6 The shutdown buttons are not allowed to be easily removable, e.g. they must not be mounted onto removable body work.

EV5.4 Brake-Over-Travel-Switch

The Brake-Over-Travel-Switch as defined in T7.3 must shut down the tractive system by activating the shutdown circuit and opening the AIRs, see EV5.1.

EV5.5 Insulation Monitoring Device (IMD)

- EV5.5.1 Every car must have an insulation monitoring device (IMD) installed in the tractive system.
- EV5.5.2 The IMD must be a Bender A-ISOMETER ® iso-F1 IR155-3203 or -3204 or equivalent IMD approved for automotive use. Equivalency may be approved by the rules committee based on the following criteria: robustness to vibration, operating temperature range, IP rating, availability of a direct output, a self-test facility and must not be powered by the system which is monitored.
- EV5.5.3 The response value of the IMD must be set to 500 Ohm / Volt, related to the maximum tractive system operation voltage.
- EV5.5.4 In case of an insulation failure or an IMD failure, the IMD must open the shutdown circuit. This must be done without the influence of any programmable logic. See also EV5.1.4 and EV5.1.5 regarding the re-activation of the tractive-system after an insulation fault.
- EV5.5.5 The status of the IMD must be shown to the driver by a red indicator light in the cockpit that is easily visible even in bright sunlight. This indicator must light up, if the IMD detects an insulation failure or if the IMD detects a failure in its own operation e.g. when it loses reference ground. The IMD indicator light must be clearly marked with the lettering "IMD".

EV5.6 Brake System Plausibility Device (BSPD)

A standalone non-programmable circuit must be used on the car such that when braking hard (without locking the wheels) and when a positive current is delivered from the motor controller (a current to propel the vehicle forward), the AIRs will be opened. The current limit for triggering the circuit must be set at a level where 5kW of electrical power in the DC circuit is delivered to the motors at the nominal battery voltage. The action of opening the AIRs must occur if the implausibility is persistent for more than 0.5sec. This device must be provided in addition to the plausibility checks which are carried out by the controller which interprets the drivers torque request and delivers torque to the wheels. See also EV5.1.4 and EV5.1.5 regarding the re-activation of the tractive system after triggering of the BSPD.

The team must devise a test to prove this required function during Electrical Tech Inspection. However, it is suggested that it should be possible to achieve this by sending an appropriate signal to the non-programmable circuit that represents the current to achieve 5kW whilst pressing the brake pedal to a position or with a force that represents hard braking.

EV5.7 Inertia Switch

- EV5.7.1 All vehicles must be equipped with an inertia switch. This must be a Sensata Resettable Crash Sensor or equivalent.
- EV5.7.2 The inertia switch must be part of the shutdown circuit and must be wired in series with the shutdown buttons such that an impact will result in the shutdown circuit being activated and the AIRs being opened. The inertia switch must latch until manually reset.
- EV5.7.3 The device must trigger due to an impact load which decelerates the vehicle at between 6g and 11g depending on the duration of the deceleration (see spec sheet of the Sensata device).
- EV5.7.4 The inertia switch may be reset by the driver from within the driver's cell.
- EV5.7.5 The device must be mechanically attached to the vehicle; however, it must be possible to demount the device so that its functionality may be tested by shaking it.

EV5.8 Charging Shutdown Circuit

- EV5.8.1 The charging shutdown circuit when charging consists of at least the charger shutdown button, the insulation monitoring device (IMD) and the accumulator management system (AMS).
- EV5.8.2 If the shutdown circuit is opened by the AMS or the IMD the tractive system must remain disabled until it is manually reset.
- EV5.8.3 The charging shutdown systems must comply with EV5.1.1, EV5.1.3, EV5.1.6, EV5.1.8, EV5.1.9 and EV5.1.10.
- EV5.8.4 The charger must include a push type emergency stop button which has a minimum diameter of 25mm and must be clearly labeled.

ARTICLE 6: FUSING

EV6.1 Overcurrent Protection

- EV6.1.1 All electrical systems (both low and high voltage) must have appropriate overcurrent protection.

The continuous current rating of the overcurrent protection must not be greater than the continuous current rating of any electrical component, for example wire, busbar, cell or other conductor that it protects.

Note: Fuses are the most common form of overcurrent protection.

- EV6.1.2 All overcurrent protection devices must be rated for the highest voltage in the systems they protect. Overcurrent protection devices used for DC must be rated for DC, and must carry a DC rating equal to or greater than the system voltage.

- EV6.1.3 All overcurrent protection devices must have an interrupt current rating which is higher than the theoretical short circuit current of the system that it protects.
- EV6.1.4 If multiple parallel batteries, capacitors, strings of batteries or strings of capacitors are used then each string must have individual overcurrent protection to protect all the components on that string. Any conductors, for example wires, busbars, cells etc. conducting the entire pack current must be appropriately sized for the total current that the individual overcurrent protection devices could transmit or additional overcurrent protection must be used to protect the conductors.
- EV6.1.5 Battery packs with low or non-voltage rated fusible links for cell connections may be used provided that:
1. An overcurrent protection device rated at a current three times lower than the sum of the parallel fusible links and complying with Section EV6.1.1 is connected in series.
 2. The accumulator monitoring system can detect an open fusible link, and will shut down the electrical system by opening the AIRs if a fault is detected.
 3. Fusible link current rating is specified in manufacturer's data or suitable test data is provided.
- EV6.1.6 Cells with internal over-current protection may be used without external overcurrent protection if suitably rated.
- NOTE:** Most cell internal over-current protection devices are low or non-voltage rated and conditions of EV6.1.5 will apply.
- EV6.1.7 The ESF must include all details of internal and external over current protection including documentation from manufacturer for the particular series and parallel configuration, and string voltage.

ARTICLE 7: ELECTRICAL SYSTEM TESTS

EV7.1 Insulation Monitoring Device Test (IMDT)

- EV7.1.1 The insulation monitoring device will be tested during Electrical Tech Inspection. This is done by connecting a resistor between the measuring points; see EV4.4, of the tractive system and several electrically conductive vehicle parts while the tractive system is active, as shown in the example below.
- EV7.1.2 The test is passed if the IMD shuts down the tractive system within 30 seconds at a fault resistance of 50% below the response value corresponding to 250 Ohm / Volt.
- EV7.1.3 The IMDT may be repeated at any time during the event. After the car passes the test for the first time, critical parts of the tractive system will be sealed. The vehicle is not allowed to take part in any dynamic event if any of the seals are broken until the IMDT is successfully passed again.

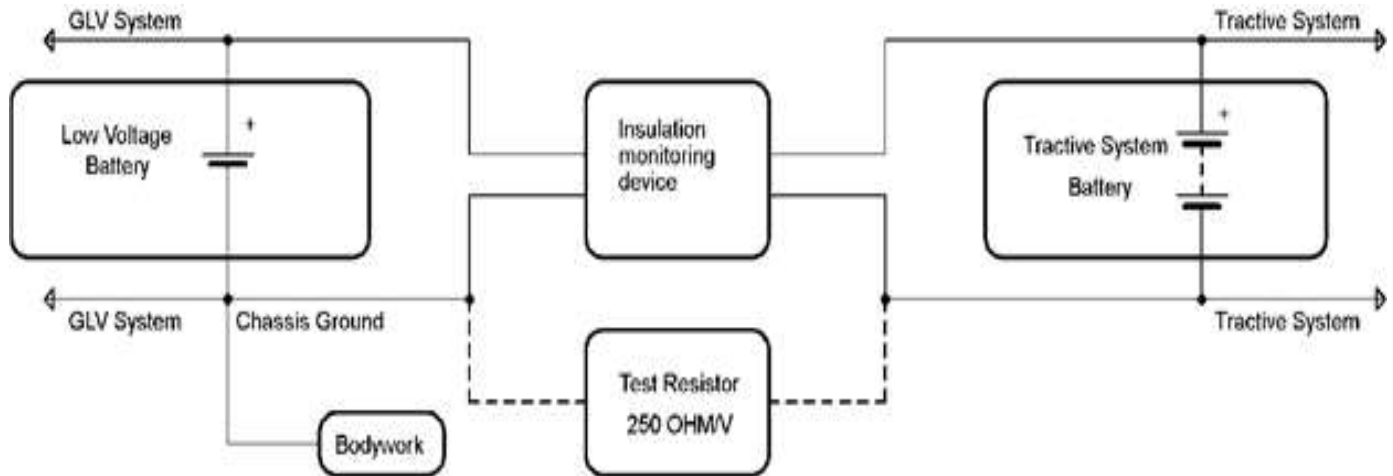

EV7.2 Insulation Measurement Test (IMT)

EV7.2.1 The insulation resistance between the tractive system and GLV system ground will be measured during Electrical Tech Inspection. The available measurement voltages are 250V and 500V. All cars with a maximum nominal operation voltage below 500V will be measured with the next available voltage level e.g. a 175V system will be measured with 250V, a 300V system will be measured with 500V etc. All teams with a system voltage of 500V or more will be measured with 500V.

EV7.2.2 To pass the IMT the measured insulation resistance must be at least 500 Ohm/Volt related to the maximum nominal tractive system operation voltage.

EV7.3 Rain test

EV7.3.1 Teams have to pass a rain test during Electrical Tech Inspection to be allowed to move the car under its own power on the event. The car must pass the IMDT; see EV7.1, before the rain test can be performed.

EV7.3.2 During the rain test the tractive system must be active and none of the driven wheels may touch the ground. The car must NOT be in ready-to-drive-mode. It is not allowed to have a driver seated in the car during the rain test.

Water will then be sprayed at the car from any possible direction for 120 seconds. The water spray will be rain like. Therefore, there will be no direct high-pressure water jet shot at the car.

EV7.3.3 The test is passed if the insulation monitoring device does not react while water is sprayed at the car and 120 seconds after the water spray has stopped. Therefore, the total time of the rain test is 240 seconds, 120 seconds with water-spray and 120 seconds without.

EV7.3.4 Teams have to make sure that water cannot aggregate anywhere in the chassis.

ARTICLE 8: HIGH VOLTAGE PROCEDURES & TOOLS

EV8.1 Working on Tractive System Accumulator Containers

EV8.1.1 Opening of or working on accumulator containers is only allowed in the charging area, see EV8.2, and during Electrical Tech Inspection.

EV8.1.2 Whenever the accumulator containers are opened the cell segments must be separated by using the maintenance plugs, see EV3.3.3.

- EV8.1.3 Whenever the Accumulator or tractive system is being worked on, only appropriate insulated tools may be used.
- EV8.1.4 Safety glasses with side shields must be worn by all participating team members when (a) parts of the tractive system are exposed while it is active, or (b) work is being done on the accumulators.

EV8.2 Charging

- EV8.2.1 There will be a separated charging area on the event site. Charging tractive system accumulators is only allowed inside this area.
- EV8.2.2 Accumulators **must** be removed from the car for charging within a removable accumulator container and placed on the accumulator container hand cart for charging.
- EV8.2.3 The accumulator containers must have a label with the following data during charging: Team name and Electrical System Officer phone number(s).
- EV8.2.4 No grinding, drilling, etc. is allowed in the charging area.
- EV8.2.5 At least one team member who has knowledge of the charging process must stay with the accumulator(s) / car during charging.
- EV8.2.6 Moving accumulator cells and/or accumulator segment(s) around at the event site is only allowed inside a completely closed accumulator container.

EV8.3 Chargers

- EV8.3.1 Only chargers presented and sealed at Electrical Tech Inspection are allowed. All connections of the charger(s) must be isolated and covered. No open connections are allowed.
- EV8.3.2 All chargers must either be accredited to a recognized standard e.g. CE or where built by the team they must be built to high standards and conform with all electrical requirements for the vehicle tractive system, for example EV4.1, EV4.3 and EV4.6 as appropriate.
- EV8.3.3 The charger connector must incorporate an interlock such that neither side of the connector become live unless it is correctly connected to the accumulator.
- EV8.3.4 HV charging leads must be orange
- EV8.3.5 When charging, the AMS must be live and must be able to turn off the charger in the event that a fault is detected.
- EV8.3.6 When charging the accumulator, the IMD must be active and must be able to shut down the charger. Either the charger must incorporate an active IMD or an active IMD must be within the accumulator.

EV8.4 Accumulator Container Hand Cart

- EV8.4.1 In order to accommodate charging, a hand cart to transport the accumulators must be presented at Electrical Tech Inspection.
- EV8.4.2 The hand cart must have a brake such that it can only be released using a dead man's switch, i.e. the brake is always on except when someone releases it by pushing a handle for example.
- EV8.4.3 The brake must be capable to stop the fully loaded accumulator container hand cart.

- EV8.4.4 The hand cart must be able to carry the load of the accumulator container(s).
- EV8.4.5 The hand cart(s) must be used whenever the accumulator container(s) are transported on the event site.
- EV8.5** Each team must present the following basic set of tools in good condition during technical inspection:
- Insulated cable shears
 - Insulated screw drivers
 - Multimeter with protected probe tips
 - Insulated tools, if screwed connections are used in the tractive system
 - Face Shield
 - HV insulating gloves which are within test date
 - 2 HV insulating blankets of at least 1.0m² each
 - Safety glasses with side shields for all team members that might work on the tractive system or accumulator

All electrical safety items must be rated for at least the maximum tractive system voltage.

ARTICLE 9: ELECTRICAL SYSTEM FORM AND FMEA

EV9.1 Electrical System Form (ESF)

- EV9.1.1 Prior to the event all teams must submit clearly structured documentation of their entire electrical system (including control and tractive system) similar to the SEF called electrical system form (ESF).
- EV9.1.2 The ESF must visualize the interconnection of all electric components including the voltage level, the topology, the wiring in the car and the construction and build of the accumulator(s).
- EV9.1.3 Teams must present data sheets with rated specifications for all tractive system parts used and show that none of these ratings are exceeded (including wiring components). This includes stress caused by the environment e.g. high temperatures, vibration, etc.
- EV9.1.4 A template including the required structure for the ESF will be made available online – see website for your competition or www.fsaonline.com.
- EV9.1.5 The ESF must be submitted as Adobe PDF-File.
- EV9.1.6 The minimum allowed font size is 11pts. The font used must be Arial. Small pictures and small schematics should be put inside the text for easy reference, not in the appendix.
- EV9.1.7 Data sheets and large schematics should be put in the appendix.

NOTE: Passing the ESF does not mean that you automatically pass Electrical Technical Inspection with the described items / parts.

EV9.2 Failure Modes and Effects Analysis (FMEA)

- EV9.2.1 Teams must submit a complete failure modes and effects analysis (FMEA) of the tractive system prior to the event.
- EV9.2.2 A template including required failures to be described will be made available online – see your competition website for details.



Do not change the format of the template. Pictures, schematics and data sheets to be referenced in the FMEA have to be included in the FMEA on additional table pages

EV9.3 Submission of the ESF or FMEA

Electrical Systems Form (ESF) or Failure Modes and Effects Analysis (FMEA) must be submitted in compliance with the procedure and by the deadline published on the website of the competition your team is attending.

EV9.4 Penalty for Late Submission or Non-submission

Penalties for Late Submission of the ESF or FMEA will be imposed per A8.4.1.



2017-18 FORMULA SAE PART S - STATIC EVENT REGULATIONS

ARTICLE 1: STATIC EVENTS AND MAXIMUM SCORES

The maximum possible scores in the static events are:

Technical Inspection	No Points
Cost and Manufacturing	100 Points
Presentation	75 Points
<u>Design</u>	<u>150 Points</u>
Total	325 Points

ARTICLE 2: TECHNICAL INSPECTION

S2.1 Objective of Technical Inspection

The objective of technical inspection is to determine if the vehicle meets the FSAE Rules requirements and restrictions and if, considered as a whole, it satisfies the intent of the Rules.

S2.1.1 For purposes of interpretation and inspection the violation of the intent of a rule is considered a violation of the rule itself. (See Rule A3.6)

S2.1.2 Technical inspection is a non-scored activity.

S2.2 Inspection & Testing Requirement

Each vehicle must pass all parts of technical inspection and testing, and bear the inspection stickers, before it is permitted to participate in any dynamic event or to run on the practice track.

S2.2.1 All items on the Inspection Form must be clearly visible to the technical inspectors.

S2.2.2 Visible access may be provided by removing body panels or by providing removable access panels.

S2.3 Team Responsibility

Teams are responsible for confirming that their vehicle, and the required equipment, satisfies the requirements and restrictions of the FSAE Rules before presenting it for Technical Inspection.

S2.3.1 Presenting a vehicle for Technical Inspection constitutes a declaration by the team that they have determined by self-inspection that the vehicle complies with the Rules.

S2.4 Items to be Inspected

The following items **must** be brought to Technical Inspection:

- Vehicle
- Technical Inspection Form
- Dry and wet tires
- Driver's equipment - for all drivers including arm restraints, helmets, suits, gloves, eye protection, balaclavas, socks and shoes.
- Fire extinguishers
- Push bar
- Structural Equivalency Spreadsheet (SES) copies **or** Structural Requirements Certification Form (SRCF) copies, as appropriate for your car.

- Impact Attenuator Report copies
- Electric cars only: Electrical System Form
- Electric cars only: FMEA
- Copies of any rules questions you submitted with the answer you received.
- All drivers must be present at inspection.

S2.5 Technical Inspection Procedure

Technical inspection will examine all items included on the Inspection Form found on the SAE website plus any other items the inspectors may wish to examine to ensure conformance with the Rules. The exact procedures and instruments employed for inspection and testing are entirely at the discretion of the Chief Technical Inspector.

S2.5.1 Decisions of the inspectors and the Chief Technical Inspector concerning vehicle compliance are final and are not permitted to be appealed.

S2.6 Inspection Condition

Vehicles must be presented for technical inspection in finished condition, i.e. fully assembled, complete and ready-to-run. Technical inspectors will not inspect any vehicle presented for inspection in an unfinished state.

NOTE: Cars may be presented for technical inspection even if final tuning and set-up has not been finished.

S2.7 Inspection Process

Vehicle inspection will consist of three separate parts as follows:

S2.7.1 Part 1 – Electrical and Mechanical Technical Inspection

EVs have to pass electrical Technical Inspection first, before being allowed to attend mechanical Technical Inspection. EVs may only be moved around the event site with the HVD disconnected until they have passed electrical Technical Inspection. This includes participation in any static events.

Each vehicle will be inspected to determine if it complies with the requirements of the rules. This inspection will include examination of the driver's equipment (Part T ARTICLE 14:) and a test of the driver egress time (Rule T4.8).

Part 1 must be passed before a vehicle may apply for Part 2 and Part 3 inspection.

S2.7.2 Part 2 – Tilt Table Tests

Each vehicle will be tested to insure it satisfies both the forty-five-degree (45°) fuel and fluid tilt requirement (Rule T8.5) and the sixty-degree (60°) rollover stability requirement (Rule T6.7.2).

Parts 1 and 2 must both be passed before a vehicle may apply for Part 3 inspection.

S2.7.3 Part 3 – Noise, Master Switch, Ready-To-Drive-Sound, Rain Test and Brake Tests

IC Vehicles - Noise will be tested by the specified method (Rule IC3.2). If the vehicle passes the noise test, then its master switches (Rule IC4.1) will be tested.

EV Vehicles - If the vehicle is an EV, the Ready-To-Drive-Sound Test (EV4.13.3) will be conducted instead of the Noise and Master Switch tests. If the vehicle passes both the noise and master switch or the Ready-To-Drive-Sound tests respectively then the rain test (EV7.3) will be performed before its brakes will be tested by the specified method (Rule T7.2).

S2.8 Correction and Re-inspection

- S2.8.1 If any part of a vehicle does not comply with the Rules, or is otherwise deemed to be a concern, then the team must correct the problem and have the car re-inspected.
- S2.8.2 The judges and inspectors have the right to re-inspect any vehicle at any time during the competition and require correction of non-compliance.

S2.9 Inspection Stickers

Inspection stickers issued following the completion of any part of Technical Inspection will be placed on the upper nose of the vehicle as specified in Rule T13.4 “Technical Inspection Sticker Space”.

- S2.9.1 Inspection stickers are issued contingent on the vehicle remaining in the required condition throughout the competition.
- S2.9.2 Inspection stickers may be removed from vehicles that are not in compliance with the Rules or are required to be re-inspected.

S2.10 “As-Approved Condition”

Once a vehicle has passed inspection, except as specifically allowed under Rule T1.2 “Modification and Repairs”, it must remain in the “As-approved” condition throughout the competition and must not be modified.

S2.11 Inspection Validity

Technical approval is valid only for the duration of the specific Formula SAE competition during which the inspection is conducted.

ARTICLE 3: BUSINESS LOGIC CASE

S3.1 The Objectives of the Business Logic Case are to:

- a. Teach participants about the factors that need to be considered when a company embarks on development of a new product. These include: cost; identification of market and likely sales volume; profitability; the key features applicable to the selected vehicle concept and target market size.
- b. Ensure teams develop the concept of their entry with all of these aspects correctly considered, from the outset.
- c. Ensure that all three static events are approached with a single common concept and presented to each set of static judges in the same manner.
- d. Ensure that participants gain experience in producing a business case and balancing potentially conflicting attributes.

S3.2 The Design, Cost and Business Presentation judges will use the business logic case to verify that the information presented at each static event is consistent with the overall objectives as outlined in the Static Events Rules.

- a. In the Design event, the business logic case may be used to identify how the team determined the trade-off between design for performance and design for manufacture and cost, how these requirements were considered in the overall concept and whether these were achieved in the final vehicle.
- b. In the Cost event, the business logic case may be used to determine that the cost target was met for the same design solution and how Cost was integrated into the overall concept and the iterative design process.

- c. In the Business Presentation event, the business logic case will be used to assess whether the business presentation is appropriate for the market and business strategy that the team has identified
- d. For some Formula Student/FSAE Events, if the event is oversubscribed, then the entry selection process may include assessment of the quality of the Business Logic Case supplied.

S3.3 All teams must submit a Business Logic Case report in accordance with the general format applicable for the year of competition “FSAE Business Logic Case 201X”. The report must be submitted on the template. Refer to the applicable competition website to acquire the template.

This report must be submitted by the deadline. Refer to the deadlines posted on the website for each specific competition. Penalties for Late Submission will be imposed per A8.4.1.

ARTICLE 4: COST AND MANUFACTURING EVENT

Important Notice: *For 2017 Formula SAE Competitions in United States, Cost Report Submission process may be changed. Please refer to the website for additional announcements and information.

Note: Additional information about the Cost and Manufacturing Event including Cost Tables and other information may be obtained from the www.fsaeonline.com website which is also linked off the Formula SAE Rules and Important Documents page on the FSAE Website.

S4.1 Event Objective

The objectives of the Cost and Manufacturing Event are:

- a. To teach the participants that cost and budget are significant factors that must be considered in any engineering exercise.
- b. For teams to make trade off decisions between content and cost based on the performance advantage of each part and assembly.
- c. To gain experience with creating and maintaining a Bill of Material (BOM).
- d. For the participants to learn and understand the principles of Design for Manufacture and Assembly, lean manufacturing and Minimum Constraint Design.

S4.2 Rules Objective

The objectives of the Cost and Manufacturing Event rules are:

- a. To provide a logical, simple and time efficient rule set enabling students to achieve the event’s objectives.
- b. To improve fairness by providing consistent pricing guidelines independent of team geographical location by using standardized Cost Tables.
- c. To require the minimal burden of supporting documentation such as receipts or catalog pages. However, in order to convey design information to cost judges engineering documentation (drawings, process descriptions, etc.) are required.

S4.3 Event Requirements

This event is comprised of three (3) parts

S4.3.1 Part 1 “Cost Report”

The preparation and submission of a report (the “Cost Report”), which is to be sent to the Cost Judges prior to the competition. See S4.1.

S4.3.2 Part 2 “Discussion”

A discussion at the Competition with the Cost Judges around the team's vehicle. This evaluates not only the cost of the car, but also the team's ability to prepare accurate engineering and manufacturing cost estimates.

S4.3.3 Part 3 "Real Case"

A "real case" scenario where students will have to respond to a challenge related to cost or manufacturing of the student vehicle.

S4.4 **Formula SAE Michigan & Formula SAE Lincoln Reports**

Teams that are entering more than one North American competition may submit one (1) Cost Report covering all the competitions entered providing that (a) the report properly identifies the competition names and car numbers and (b) any addenda necessary to cover changes or modifications made to the vehicle between events is properly completed and submitted.

S4.5 **Public Cost Reports**

By submitting a cost report to the competition's organizing body for judging you and your team agree that your cost report may be reproduced and distributed by the competition organization, in both complete and edited versions, in any medium or format anywhere in the world.

The FSAE Rules Committee and the competition organizers may publish all cost reports, in as-submitted format, to the FSAE website. It is the intent of this move to make the cost event more transparent and improve the educational experience of the students by providing the full range of cost reports for teams to review. Cost reports for a given competition season will not be published before the end of the calendar year. Support materials, such as technical drawings, will not be released.

S4.6 **Definitions**

The following definitions will apply throughout the Cost Event rules:

S4.6.1 Adjusted Cost – The final cost for the vehicle including penalties

S4.6.2 Amended Cost – The cost of the vehicle after modification by the competition addendum

S4.6.3 Bill of Material – A hierarchical list of all parts of the vehicle. A BOM lists every item that is on the vehicle but also shows the relationships between these items, for example showing the parts that make up an assembly. A Costed Bill of Material (CBOM) is a standard BOM that includes cost information including cost of purchased parts, raw materials and processes that go into manufacturing the vehicle.

S4.6.4 Category - Each table has numerous entries which describe a classification of entry. For example, there are several types of hose clamps, and all have various costs. The category of hose clamp may be worm drive, constant tension, etc.

S4.6.5 Cost – The cost for each item from the materials table is simply the quantity multiplied by the unit cost.

S4.6.6 Cost Report – All materials, including electronic and hard copy, submitted for judging

S4.6.7 Cost Score – Refers to the total number of points out of 100 earned in the Cost Event

S4.6.8 Cost Tables – All tables that list costs for objects and processes

S4.6.9 Design for Manufacture and Assembly (DFMA) – The process where parts are designed for ease of manufacture and assembly, resulting in lower cost.

- S4.6.10 Fasteners Table – A Cost Table that consists of not only traditional fasteners such as bolts, nuts and rivets but also adhesives, hose clamps and retaining rings.
- S4.6.11 Fixed Cost – Costs associated with production that is independent of volume produced. Fixed cost items, such as tooling, are converted to variable costs when included in the Cost Report.
- S4.6.12 Initial Cost – The cost of the vehicle submitted for initial judging in the Cost Report.
- S4.6.13 Lean Manufacture – A methodology for producing goods that emphasizes the elimination of waste and improvement in process flow with the goal of optimizing the cost and quality of goods.
- S4.6.14 Materials Table – Lists the costs for raw materials used to manufacture parts built by the teams and also of finished parts purchased by the teams.
- S4.6.15 Minimum Constraint Design (MCD) – A design methodology emphasizing elimination of redundant constraints in the attachment of parts. Each part requires constraint in six degrees of freedom and additional constraints can make assembly difficult, force tight tolerances and increase the cost of manufactured goods.
- S4.6.16 Parameters – Used to create an equation describing the cost of an object as a function of some characteristic of that object. For example, the cost of steel is proportional to the mass (or volume) of steel. In this case steel has been parameterized by mass. Rubber hose could be parameterized by diameter. The equations can be linear or non-linear and both 1st and 2nd order equations are used as necessary to build the Cost Tables.
- S4.6.17 Process Multipliers - Modify the standard costs of different operations to account for material and geometric differences in the part.
- S4.6.18 Purchased Parts – Also called bought parts; these items are listed in the Cost Tables in a near as-installed condition. For example, wheels, engines and turbochargers are purchased parts. In some cases, purchased parts may still require additional processing before they can be assembled to the car. Wheels, for example, do not include the machined features for mounting to the hub. Purchased parts do not include fasteners unless specifically noted in the Cost Tables.
- S4.6.19 Quantity – The amount of the item
- S4.6.20 Raw Materials – Materials used for manufacturing parts, such as aluminum, steel and rubber hose.
- S4.6.21 Tools – Tools refer to hand or power tools used to assemble the vehicle. The costs of these tools **are not included** in the Cost Report. The effect of the tools used for assembly are captured in the process tables for labor as different costs are given based on the tools used for assembly.
- S4.6.22 Tooling - Is the production tooling associated with processes that are specific to the part geometry. The costs of tooling **must be included** in the Cost Report. For example, the dies to stamp out a chassis bracket are tooling. The press used to stamp the bracket is not, and is considered production equipment which is not part of the Cost Event.
- S4.6.23 Unit – Is the measurement system used to define the quantity of a parameter. For example, millimeters and kilograms are units. The hose clamp diameter unit is mm. When calculating the cost of the clamp the unit of measurement used by the team must match the Unit specified in the tables. For example, a US team mistakenly calculates the hose clamp cost by using

the expression with a diameter of 1, because their radiator hose is 1 inch in diameter. They should have used 25.4mm for the diameter and their cost is wrong because of it. For the penalties associated with this type of error see S4.19

S4.6.24 Unit Cost – Is the cost for something assuming a numerical value of one (1) of the unit used to measure the item. The cost is the quantity of an item multiplied by the unit cost.

S4.6.25 Variable Cost – Is a cost associated with production that is proportional to the vehicle volume produced. All costs submitted with the Cost Report will be variable costs.

S4.7 General Requirements

S4.7.1 The Cost Report must:

- Use the standardized Cost Tables. The tables are designed to reflect a hypothetical car built for production at the annual volume of 1000 units per year.
- List and cost every part on the prototype vehicle. This includes any equipment fitted on the vehicle at any time during the competition. The only exceptions are that, per S4.23 “Cost Report Exempt Items” of the Rules, the cost of any finish, on-board fire suppression system, rain tires, video or radio system, does not need to be included in the Cost Report.
- Be based on the estimated costs of materials, fabrication, purchased parts, and assembly of the car. The costs must be calculated as defined in these rules.
- Be based on the actual manufacturing technique used on the prototype, e.g. cast parts on the prototype must be cost as cast, and fabricated parts as fabricated, etc.
- Include tooling (e.g. welding jigs, molds, patterns and dies) for processes requiring it.
- Exclude R & D and capital expenditures (e.g. plant, machinery, hand tools and power tools).

There is no maximum cost. Receipts are not required for any items.

S4.7.2 The Cost Tables have been designed to:

- Be verifiable at the event. Differentiating between different types of materials (for example different alloys of steel) is not possible so no differentiation is made in the table cost.
- Minimize influence on safety equipment content. For example, driver harnesses are cost independent of the style chosen.
- Higher costs of some goods must reflect actually higher value of those goods. However, the costs must still allow for team innovation and vehicle content, with some reduction in cost score.

S4.8 Scoring

The points for the Cost and Manufacturing Event will be broken down as follows:

$40x\left[\frac{(P_{max})}{(P_{your})}-1\right]$ $\left[\frac{(P_{max})}{(P_{min})}-1\right]$	40 Points	Lowest cost - each of the participating schools will be ranked by total adjusted cost from the BOM and given 0-40 points based on the formula on the left.
	40 Points	Accuracy, Clarity & Event Day/Visual Inspection - The cars will be reviewed for part content, manufacturing feasibility and accuracy of the cost information. Supporting documentation will be assessed based on its quality, accuracy and thoroughness. The range for the score is 0-40 points.
	20 Points	Event Day/Manufacturing Processes - The teams must be prepared to discuss in detail the “real case” scenario distributed prior to the competition. The materials will include more specifics about the goal and scoring of the scenario. The range for the score is 0-20 points.
Total	100 Points	

Where:

P_{your} is the adjusted cost of your car (with penalties) in dollars.

P_{min} is the adjusted cost of the lowest cost car in dollars.

P_{max} is the cost of the highest cost car in dollars.

S4.9 Cost Report

S4.9.1 The Cost Report consists of a full vehicle BOM with cost data derived from the Cost Tables and supporting documentation. The Cost Report must be submitted in two (2) forms:

- a. Electronic Version – The upload of the electronic cost report has to be done in these steps:
 - i. Upload of the vehicle BOM as Microsoft Excel ® file (.xls or .xlsx)
 - ii. Upload of the supporting material as one separate PDF file (.pdf)

The electronic version of the two files must be identified as follows:

Carnumber_schoolname_competitioncode_CR_BOM.xls using the assigned car number, the complete school name and the competition code.

Example: 087_University of FSAE_FSAEM_CR_BOM.xls

Carnumber_schoolname_competitioncode_CR_Supplement.pdf using the assigned car number, the complete school name and the competition code for the BOM.

Example: 087_University of FSAE_FSAEM_CR_Supplement.pdf

Competition Codes are listed in Rule A2.6

- b. Hard Copy – The hard copy Cost Report must be in a ring binder with 8.5” x 11” or A4 pages including both the BOM and supporting documentation (Annex).
- c. A complete submission includes all portions of the electronic cost report and the hard copy. The electronic version of the Cost Report must be submitted via fsaeonline.com. The hard copy must be mailed to the address posted on sae.org. The hard copy must also include a copy of the electronic files on a memory stick or CD.

NOTE: Some competitions may waive the hard copy requirement. If so, the waiver will be published on the SAE website. Also note that the electronic submission has been broken into multiple parts to enable the BOM to be posted per rule S4.5 without posting the supporting documentation.

S4.9.2 Cost Report Identification

The cover of the Cost Report must include the following:

(a) university name, (b) competition name, and (c) vehicle number.

Teams that are submitting a single Cost Report covering more than one North American competition must identify their report as follows:

University Name (full name)

Formula SAE Michigan, Car # XXX and Formula SAE Lincoln, Car #YYY

S4.9.3 The Cost Report must consist of the following:

- A Cover sheet
- A Table of Contents
- A Cost Summary page listing each section’s cost, and the total vehicle cost
- Eight commodity report sections with the parts placed in the sections as specified in Appendix S-3.

- Tabs for each section

S4.10 Bill of Materials (BOM)

The BOM is a parts list for every vehicle part. It also shows the relationships between the items.

S4.10.1 The following terminology will be used when referring to the BOM.

- The overall vehicle is broken down into eight (8) systems which are defined in Appendix S-3.
- Systems are made up of Assemblies.
- Assemblies are made up of Parts.
- Parts consist of materials, processes and fasteners.
- Tooling is associated with each process that requires production tooling.

S4.10.2 An example BOM structure is shown below:

- Engine & Drivetrain..... System
 - Engine..... Assembly
 - Differential..... Assembly
 - Housing..... Part
 - Aluminum..... Material
 - Needle Bearing..... Material
 - Sand cast..... Process
 - Die & Core Package #4..... Tooling
 - Machining-Turn..... Process
 - Weld..... Process
 - M6x1.25 Grade 8.8..... Fastener
 - Internals..... Part
 - End Cap..... Part

The BOM must follow the format given above. There must be no other BOM levels added or any removed. Deviations from the structure published will be penalized per Section S4.18.

S4.10.3 All assemblies, parts and fasteners in the BOM must use a standard numbering convention explained in Appendix S-2.

S4.11 The Cost Tables

S4.11.1 All costs in the Cost Report come from the standardized Cost Tables. These tables have been compiled to represent the cost of parts and processes that a manufacturing company could be expected to pay for manufacturing a vehicle at 1000 units per year. Generally, the tabulated value represents ½ of the Manufacturer’s Suggested Retail Price (MSRP) for finished parts. Raw materials, commodities and fasteners also intended to represent the production volume of a company rather than the purchase price of the University teams.

S4.11.2 Requests to alter the cost of goods in the tables because of changing world markets or individual team purchase price will not be approved. The tables are intended to provide a fair, unchanging (within a given competition year) cost for parts and to reduce regional variations in price that may help or hurt certain teams. All teams must use the costs given in the tables. If a team wishes to use any parts, processes or materials not included in the tables an “Add Item Request” must be submitted as per Section S4.14.

S4.11.3 The tables represent cost based on specific parameters. For example, the cost of steel is given per unit of volume (or mass). Likewise, engine costs are listed by displacement and specific power output.

S4.11.4 The following Cost Tables are used

- Materials
- Processes
- Process Multipliers
- Fasteners
- Tooling

Engine cost includes transmission (whether integral or not by design), components used to transmit power between engine and transmission and all components necessary to run including spark plugs, coils, wires, oil filter, etc. with the exception of the air induction and fuel system components. Any driveline component downstream of the transmission output gear/shaft is not included. Cost includes engine as received by manufacturer but not custom parts such as dry sump pans, PCV changes, etc. Fully internal engine changes are free. If covers or other parts are removed disassembly labor must be included in labor cost.

S4.11.5 In general, most items have a cost expressed as a function of one parameter. In cases where more than one parameter is necessary additional categories are listed. For example, the power output of the engine has three Categories and for each Category a different expression calculates the cost as a function of the engine displacement, which is the Parameter. The Unit would be cubic centimeters in this case.

S4.11.6 Process Multipliers are used to modify the standard costs of different operations to account for material and geometric differences in the part. For every process included in the Cost Report the list of process multipliers must be checked to determine if any apply, and if they do their effect on the cost must be included.

S4.11.7 When adding items from tables to the BOM the comments section should be reviewed thoroughly to understand what is included in the table entry. For example, is the spring included in the damper cost? Do the spark plugs come with the engine or are they a separate line item? In cases where the explanation is not clear please contact the Rules Committee for clarification.

S4.12 Cost Models & Costing Methodology

The cost models are the underlying methodology and equations that relate the final cost of a part or process to the different operations and goods used in that part. The detailed explanation of the Cost Models and Costing Methodology is included in Appendix S-1 and should be referenced for understanding the use of the Cost Tables.

S4.13 Make Versus Buy

Every part on an individual car can be classified as “made” or “bought”. This designation does not necessarily refer to whether a team actually purchased or fabricated a part but is a reflection of how the part must be cost from the Cost Tables.

- a. Made (or manufactured) parts must be cost as if the company manufacturing the vehicle was going to make the part internally. That is by purchasing raw materials and processing them into a finished product.
- b. Bought parts must be cost as if the company manufacturing the vehicle was going to outsource the fabrication of that part. These parts would be received by the vehicle manufacturer in a relatively finished state (see the particular table entry comments field for specific information).

S4.13.1 The Cost Tables have been constructed as a tradeoff between complexity for the organizers and fairness for the teams. The make versus buy designation enables certain parts to be simplified to a relatively few number of entries. For example, some teams may purchase axles but the majority of teams manufacture them. Axles are designated “make” parts so teams that purchase axles **must** cost

them as if they had made them starting with the raw materials, in this case probably steel tubing. Made parts can be distinguished because they do not appear explicitly in the Cost Tables or appear with a “cost as made” option.

S4.13.2 If a team genuinely makes a part listed on the table as a bought part, they may alternatively cost it as a made part **if and only if** a place holder entry is listed in the tables enabling them to do so. For example, in the category of dampers a “student built” entry is included. This line item must be included in the BOM (it has zero cost). Then they must proceed to cost the damper they actually designed and built.

S4.13.3 A table summary of options is given below:

How Table Lists Part	How Team Actually Acquired the Part	
	Team Made	Team Bought
Table Lists Part as "Made", or Part is not Listed in the Tables	Cost as "Made"	Cost as "Made"
Table Lists Part as "Bought"	Team made option NOT in table cost as "Bought". If team made option in table team can choose either "Bought" or "Made"	Cost as "Bought"

S4.13.4 For example, a snap ring does not have a “team made” entry in the Cost Tables. A team who made their own would still have to use the table cost based on diameter, even if they could cost it less expensively by buying steel and processing it.

S4.13.5 Any part which is normally purchased that is optionally shown as a made part must have supporting documentation submitted to prove team manufacture. This might include engineering drawings, pictures of machining, etc. Teams found costing bought parts as made parts will be penalized appropriately.

S4.14 Add Item Request

S4.14.1 The costs tables are intended to include all materials, processes and fasteners needed by the teams to accurately reflect the content, manufacture and assembly of their vehicle. However, it will be necessary to add items to the tables to suit individual team requirements. To do this an “Add Item Request” must be submitted to the Rules Committee. After review the item will be added to the tables with the next table update with a cost appropriate to the overall Cost Table framework and spirit of the competition.

The tables will be updated throughout the competition year as required.

S4.14.2 The form should be completely filled out and contains the necessary instructions. Some supporting documentation will be required such as receipts or website links. The Add Item request is the only time receipts will be needed for the Cost Event.

NOTE: Since all teams work off the same tables once a team requests an item be added to the tables all teams will see the addition. Any team using the newly added item will use the same cost. The identity of the school that made the request will not be published.

S4.15 Report Submission and Deadline

- a. The Cost Report must be submitted in the designated format for each event.
- b. For some events, a printed copy of the report must also be submitted and must be on 8 1/2-inch x 11 inch or A4 size paper, using a 10-point font size or larger.
- c. Submission Address and Deadline – The submission requirements, address and deadline will be published in the appendix or released on the website of the specific competition.

S4.16 Late Submission of Cost Report

Penalties for Late Submission will be imposed per A8.4.2. Penalties will be applied based on official upload date and time for electronic submission and by post mark for printed submissions.

S4.17 Addenda

S4.17.1 An addendum that reflects any changes or corrections made after the submission of the Cost Report must be submitted at Registration when the Team registers on-site at the Event. It will not be accepted at any other time or place. The addendum document must follow the template format specified in Appendix C-5. No other format will be accepted.

S4.17.2 Addenda apply only to the competition at which they are submitted. A separate addendum is permitted for every competition a vehicle attends.

S4.17.3 Any items added to the Cost Report through addenda will be cost at 1.25 times the table cost. Any items removed through addenda will only be credited 0.75 times the table cost.

NOTE: Late changes to designs impact costs in the real world. Contracts need to be altered, commodity costs can change, cancellation fees may be incurred and information needs to be transmitted to suppliers. The scaling factors for the addenda capture this as well as encourage teams to submit full and accurate information with the initial Cost Report.

S4.18 Cost Report Judging and Penalties Process

S4.18.1 The following procedure will be used in determining penalties:

- a. Penalty A will be calculated first using procedure S4.19
- b. Penalty B will then be calculated using alternative procedure S4.20
- c. The greater of the two penalties will be applied against the cost score
 - i. Penalty A expressed in points will be deducted from the Accuracy score
 - ii. Penalty B expressed in dollars will be added to the Adjusted Cost of the vehicle
- d. If no additional points remain to be deducted from the Accuracy score the penalty will be applied using method B against the Adjusted Cost

S4.18.2 If the alternative penalty is used because no additional accuracy points remain then the highest of the A type penalties will be converted to B type penalties. In effect, the order the penalties are calculated and applied against the team does not matter.

S4.18.3 Any error that results in a team over reporting a cost in their Cost Report will not be further penalized. For example, when the Cost Report is prepared the thickness of the brake rotors has not yet been determined. The team conservatively costs the rotors as 10mm thick. The final thickness is 8mm and no change is made in the addendum. The team rotor price is higher than necessary but no penalty is applied.

NOTE: The penalty system is intended to reward accuracy and minimize workload at the competition for students and judges. In most cases a standard point deduction will be made to the accuracy score.

NOTE: Any instance where a team's score benefits by an intentional or unintentional error on the part of the students will be corrected on a case by case basis.

S4.19 Penalty Method A- Fixed Point Deductions

S4.19.1 From the Bill of Material, the cost judges will determine if all parts and processes have been included in the analysis. In the case of any omission or error the judges will add a penalty proportional to the BOM level of the error. The following standard points deductions will apply:

- Missing/inaccurate material, process, fastener..... 1 pt.
- Missing/inaccurate part..... 3 pt.
- Missing/inaccurate assembly..... 5 pt.

NOTE: Each of the penalties listed above supersedes the previous penalty. If a 5-point deduction is given for a missing assembly, the missing parts are ignored for Method A. Method B would include the cost of the missing parts in the calculation.

S4.19.2 Differences other than those listed above will be deducted at the discretion of the cost judges. Examples of errors leading to points deductions:

- Five M6 fasteners listed, six used – 1 pt.
- Three kilograms of steel listed, 4.4 used – 1 pt.
- Bearing carrier face machined, mill operation not included – 1 pt.
- Installation labor for steering wheel missing – 1 pt.
- Upright cost as cast but actual part billet machined – 3 pt.
- Pneumatic shifter not included on BOM – 5 pt.

The penalties above will be deducted from the points awarded for Accuracy of the Cost Report.

S4.20 Penalty Method B – Adjusted Cost Deductions

The alternative penalty will be calculated using the following equation:

$$\text{Penalty} = 2 \times (\text{Table Cost} - \text{Team Reported Cost})$$

The table cost will be calculated from the standard Cost Tables. The penalty calculation will result in a dollar value equal to twice the difference between the team cost and the correct cost for all items in error.

This penalty, if applied, will be made to the Adjusted Cost of the vehicle.

NOTE: The table costs of all items in error are included in the calculation. A missing assembly would include the price of all parts, materials, processes and fasteners making up the assembly.

S4.21 Penalty Calculation Example

For example, the pneumatic shifter was inadvertently left off the Cost Report. As this is an assembly the standard error is 5 points. The cost of all air shifter parts and processes from the Cost Tables is \$500. This means the total penalty cost is \$1000. To see which is greater, 5 points or \$1000, the dollar penalty needs to be converted to points by reference to the Cost Points formula:

$$\text{Points} = \frac{40x[(P_{\max})/(P_{\text{your}})-1]}{[(P_{\max})/P_{\min})-1]}$$

Substitute the cost of the vehicle (P_{your}) with \$15,000 while the minimum vehicle cost (P_{\min}) was \$10,000. The maximum vehicle cost (P_{\max}) was \$50,000. Calculating the points equivalent for this dollar amount yields 2.5 points. This is less than the standard penalty. In this case the 5 points would be deducted from the Accuracy score.

If the team had made many small errors and had no more accuracy points available, then the \$1000 would be added to the team's adjusted cost.

S4.22 Discussion at the Competition

S4.22.1 At this discussion, the Cost Judges will:

- a. Review whether the specification of the vehicle in the Cost Report accurately reflects the vehicle brought to the Competition
- b. Review the manufacturing feasibility of the vehicle
- c. Assess penalties for missing or incorrect information in the Cost Report compared to the vehicle presented at inspection.

S4.22.2 The team must present their vehicle at the designated time to the Cost Judges for review of the Cost Report. Teams that miss their cost appointment will potentially lose all cost points for that day. The schedule for these appointments will be in the registration packets and/or posted on the website.

S4.23 Cost Report Exempt Items

S4.23.1 Finishes

The car will be considered to be shipped as primed or gel coated and a cost recorded. Any finishes (paint, polish, etc.) that are only used to beautify need not be costed. Preservative finishes intended to protect the appearance or function of a part for an extended period of time must be costed (labor and material included).

S4.23.2 Fire Extinguisher and Suppression System

Hand held fire extinguishers are not allowed on the vehicle (See Rule T14.14 "Fire Extinguishers"), but if the car has an on-board fire suppression system, it is not required to be costed.

S4.23.3 Tires and Wheels

Only one set of tires and wheels needs to be included in the Cost Report. The tires and wheels that are declared as dry tires per rule T6.4 "Tires" must be the tires included in the Cost Report, and must be the tires on the car during the Cost Event judging. Other tires that will be potentially used at the competition (i.e. rain tires) do not need to be included in the Cost Report.

S4.23.4 Transponders, Video and Radio Systems

Transponders, video and radio systems, need not be included in the Cost Report.

S4.23.5 Data Acquisition Systems

Data acquisition systems must be included in the Cost Report. This includes display screens, control modules and all sensors.

Systems that are "stand-alone" data acquisition systems (e.g., a device that passively logs CAN data) are to be included at \$0. Systems offering additional functionality have to have this functionality (e.g., a driver display) included, whether it is used or not.

Stand-alone systems must be removable without compromising any vehicle functionality aside from the logging capability. This capability may be audited by the judges at any time prior to the announcement of the Cost Event Results. Sensors and wiring must be included in the Cost Report using the Cost Table prices.

S4.24 Exchange Rates & Unit Systems

The currency of the Cost Report will be referred to as dollars. Since all items have a cost from the Cost Tables the actual currency unit is irrelevant.

- S4.24.1 All Cost Tables are presented using metric units. The tables do not differentiate between parts designed in metric and US systems of measure. For example, a ¼ bolt is simply input as a 6.35mm bolt. Tubing with a wall thickness of 0.035 inches is input as 0.889mm tubing. All sizes are assumed to be standard for the part being cost and no surcharge applies for any size, even if the size is non-standard. For example, a team makes a custom 6.112mm bolt which took several hours of student time. However, this bolt is chosen from the Cost Tables and is less than one dollar. The assumption is in high volume production these bolts would be purchased in bulk.
- S4.24.2 The comment section for each material, process or fastener may, at the student's discretion, refer to the specific part by actual local designation. For example, a 6.35mm bolt is cost but the comments would say "¼ inch A-arm bolt".
- S4.24.3 Because the Cost Report reflects a production cost for 1000 units per year all material and commodity sizes are assumed to be available for the necessary volume without cost penalty.

ARTICLE 5: PRESENTATION EVENT

S5.1 Presentation Event Objective – Business Case

- S5.1.1 The objective of the presentation event is to evaluate the team's ability to develop and deliver a comprehensive business case that will convince the executives of a corporation that the team's design best meets the demands of the amateur, weekend competition market, including Sports Car Club of America (SCCA) Solo, and that it can be profitably manufactured and marketed. (See also A1.2)
- S5.1.2 The judges should be treated as if they were executives of a corporation.
- S5.1.3 Teams should assume that the "executives" represent different areas of a corporate organization, including engineering, production, marketing and finance, and thus may not all be engineers.
- S5.1.4 Presentations will be evaluated on the contents, organization and visual aids as well as the presenters' delivery and the team's response to questions.
- S5.1.5 The presentation must relate specifically to the prototype vehicle as entered in the competition
- S5.1.6 The presentation must be consistent with the Design and Cost events, and any documentation submitted prior to the competition.
- S5.1.7 The actual quality of the prototype itself will not be considered as part of the presentation judging

S5.2 Presentation Schedule

- S5.2.1 Presentations will be made on the static events day.

S5.2.2 Presentations may take place in conjunction with the Cost event. If this applies, additional details will be published prior to the competition.

S5.2.3 Teams that fail to make their presentation during their assigned time period will receive zero (0) points for the event.

S5.3 Presentation Format

S5.3.1 One or more team members will give the presentation to the judges.

S5.3.2 All team members who will give any part of the presentation, or who will respond to the judges' questions, must be in the presentation area when the presentation starts and must be introduced and identified to the judges. Team members who are part of this "presentation group" may answer the judge's questions even if they did not speak during the presentation itself.

S5.3.3 Presentations are limited to a maximum of ten (10) minutes. The judges will stop any presentation exceeding ten minutes.

S5.3.4 The presentation itself will not be interrupted by questions. Immediately following the presentation there will be a question and answer session of up to five (5) minutes.

S5.3.5 Only judges may ask questions. Only team members who are part of the "presentation group" may answer the judges' questions.

S5.4 Data Projection Equipment

S5.4.1 Teams planning to use data projectors, visual display devices (tablets, computers, etc.), or other communication means as part of their presentation are responsible for bringing, or otherwise arranging for, their own projection equipment.

S5.5 Evaluation Criteria

S5.5.1 Presentations will be evaluated on content, organization, visual aids, delivery and the team's response to the judges' questions.

S5.5.2 Presentation Judging Score Sheet – The Presentation Judging Score Sheet is available at <http://fsaeonline.com>.

S5.5.3 The criteria are applied only to the team's presentation itself. The team that makes the best presentation, regardless of the quality of their car, will win the event.

S5.6 Scoring Formula

S5.6.1 The Presentation Events score is based on the average of the judges' scores.

S5.6.2 There is a maximum of fifty (50) points from the Presentation Judging Form.

PRESENTATION SCORE = $75 \times P_{\text{your}}/P_{\text{max}}$

Where:

"P_{max}" is the highest score awarded to any team

"P_{your}" is the score awarded to your team

S5.6.3 It is intended that the scores will range from near zero (0) to seventy-five (75) to provide good separation.

S5.6.4 The Presentation Event Captain may at his/her discretion; normalize the scores of different judging teams.

S5.7 Presentations without a Completed Car

Teams that unable to bring a vehicle to the competition may participate in the Presentation Event and will receive a score for that event.

Participating in the Presentation event without bringing a vehicle to the competition will not affect the status of the car you have under construction at your school. When you finish it and bring it to a competition it will still be a first year vehicle under Rules A6.6 and A6.8

ARTICLE 6: DESIGN EVENT

S6.1 Design Event Objective

S6.1.1 The concept of the design event is to evaluate the engineering effort that went into the design of the car and how the engineering meets the intent of the market both in terms of vehicle performance and overall value.

S6.1.2 The car that illustrates the best use of engineering to meet the design goals, a cost effective high performance autocross car, and the best understanding of the design by the team members will win the design event.

Comment: Teams are reminded that FSAE is an engineering design competition and that in the Design Event; teams are evaluated on their design. Components and systems that are incorporated into the design as finished items are not evaluated as a student designed unit, but are only assessed on the team's selection and application of that unit. For example, teams that design and fabricate their own shocks are evaluated on the shock design itself as well as the shock's application within the suspension system. Teams using commercially available shocks are evaluated only on selection and application within the suspension system.

S6.1.3 The design judges may also consult the Business Logic Case that is submitted before the event. It is expected that the car that is presented at the design event should reflect the design concept that is developed in the Business Logic Case.

S6.2 Design Report – Required Submission

S6.2.1 Design Report - Judging will start with a Design Review before the event. The principal document submitted for Design Judging is a Design Report.

S6.2.2 The Design Report must not exceed eight (8) pages, consisting of not more than four (4) pages of text, three (3) pages of drawings (see S6.4, "Vehicle Drawings") and one (1) optional page containing content to be defined by the team (photo's, graphs, etc...).

S6.2.3 The document should contain a brief description of the vehicle with a review of your team's design objectives, a discussion of any important design features and vehicle concepts. Include a list of different analysis and testing techniques (FEA, dynamometer testing, etc.). Evidence of this analysis and back-up data should be brought to the competition and be available, on request, for review by the judges.

S6.2.4 These documents may be graded as part of the Design Event score, and will be used by the judges to sort teams into the appropriate design groups based on the quality of their review.

Comment: Consider your Design Report to be the “resume of your car”.

S6.3 Design Spec Sheet – Required Submission

- S6.3.1 Design Spec Sheet – A completed FSAE Design Spec Sheet must be submitted.
- S6.3.2 The FSAE Design Spec Sheet template can be found at www.fsaeonline.com. Do not alter or re-format the template prior to submission.
- S6.3.3 The design judges realize that final design refinements and vehicle development may cause the submitted figures to diverge slightly from those of the completed vehicle. For specifications that are subject to tuning, an anticipated range of values may be appropriate.
- S6.3.4 The Design Report and the Design Spec Sheet, while related, are independent documents and must be submitted as two (2) separate files,

S6.4 Vehicle Drawings

- S6.4.1 The Design Report must include one set of three (3) view drawings showing the vehicle, from the front, top, and side.
- S6.4.2 Each drawing must appear on a separate page. The drawings may be manual or computer generated.
- S6.4.3 Photos should be placed on the optional page and will not be counted as drawings.

S6.5 Design Report and Design Spec Sheet Formats

- S6.5.1 The Design Report must be submitted electronically in Adobe Acrobat® Format (*.pdf file). This document must be a single file (text, drawings, and optional content all inclusive).
- S6.5.2 The Design Report file must be named as follows:
carnumber_schoolname.pdf using the FSAE assigned car number and the complete school name, e.g. 001_University of SAE.pdf
- S6.5.3 Design Spec Sheets must be submitted electronically in Microsoft Excel® Format (*.xls or.xlsx file). The format of the Spec Sheet MUST NOT be altered.
- S6.5.4 Similar to the Design Report, the Design Spec Sheet file must be named as follows:
carnumber_schoolname_specs.xls using the FSAE assigned car number and the complete school name, e.g. 001_University of SAE_spec.xls

S6.6 Excess Size Design Reports

If a team submits a Design Report that exceeds four (4) pages of text, three (3) pages of drawing and one (1) optional page, then only the first four pages of text, three pages of drawings and first optional page will be read and evaluated by the judges. If included, cover sheets and tables of contents will count as text pages.

S6.7 Submission Deadlines

- S6.7.1 The Design Report and the Design Spec collectively constitute the “Design Documents”. The Design Documents must be submitted in compliance with the specific procedure and by the deadline shown in the website for the competition your team is entering.
- S6.7.2 The Design Documents must be submitted as separate files.

- S6.7.3 Document submission will be acknowledged either on the competition website or by email. Teams should have a printed copy of this acknowledgement available at the competition as proof of submission in the event of discrepancy.
- S6.8 Penalty for Late Submission or Non-submission**
Penalties for Late Submission of all or any one of the Design Documents will be imposed per A8.4.2.
- S6.9 Penalty for Unsatisfactory Submissions**
At the discretion of the judges, teams that submit a Design Report or a Design Spec Sheet which, in the opinion of the judges does not represent a serious effort to comply with the requirements of Rules S6.2, S6.3 and S6.4 will also not compete in the design event, but may at the design judges' discretion receive between five (5) and twenty (20) points for their efforts.
- S6.10 Design Event – Vehicle Condition**
- S6.10.1 Cars must be presented for design judging in finished condition, i.e. fully assembled, complete and ready-to-run.
- S6.10.2 The judges will not evaluate any car that is presented at the design event in what they consider to be an unfinished state.
- S6.10.3 Unfinished cars that are refused judging will receive zero (0) points for design.
- S6.10.4 Point penalties may be assessed for cars with obvious preparation issues, e.g. notably loose or missing fasteners.
- NOTE:** Cars may be presented for design judging without having passed technical inspection, and even if final tuning and setup is in progress.
- S6.11 Judging Criteria**
- S6.11.1 The design judges will evaluate the engineering effort based upon the team's Design Report, Design Spec Sheet, responses to questions and an inspection of the car.
- S6.11.2 The Design Judges may assign a portion of the Design Event Points to the Design Report and Design Spec Sheet
- S6.11.3 The design judges will inspect the car to determine if the design concepts are adequate and appropriate for the application (relative to the objectives set forth in the rules).
- S6.11.4 It is the responsibility of the judges to deduct points if the team cannot adequately explain the engineering and construction of the car.
- S6.11.5 Design Judging Score Sheet – The Design Judging Score Sheets are available at <http://fsaeonline.com>. The judges strongly urge all teams to read and study the score sheets and all other documents related to design judging that are available on the website.
- We highly recommend reading “FSAE Design Judging, A Student Guide to Understanding the Process” which is available on the FSAE website.
- S6.12 Judging Sequence**
- S6.12.1 The actual format of the design event may change from competition to competition and year to year as determined by the organizing body.

S6.12.2 All Formula SAE organizing bodies reserve the right to organize Design Judging into one, two or three steps at their sole discretion.

S6.12.3 Design judging at the North American competitions is typically conducted in 2 steps.

S6.13 Scoring

S6.13.1 Scoring may range from 0 to 150 points at the judge's discretion, and may incorporate report grading and onsite judging.

S6.13.2 The judges may at their discretion award the highest placing team less than 150 points.

S6.14 Support Material

Teams may bring with them to the Design Event any photographs, drawings, plans, charts, example components or other materials that they believe are needed to support the presentation of the vehicle and the discussion of their development process.

S6.15 Second Year Cars - Penalties for Insufficient Redesign

S6.15.1 Penalties for insufficient redesign are in effect at Formula SAE Australasia, Formula SAE Brazil, Formula SAE Italy, and Student Formula Japan.

S6.15.2 The judges will deduct fifty (50) points from the final design score for cars without a new frame. (See Rule A6.9) An additional thirty (30) points may be deducted if the photographic and other supporting documentation fails to show that the remaining parts of the vehicle have been significantly changed (e.g. the intake manifold is obviously the same or it is obvious that the old suspension was simply bolted to a new frame, or none of the team members show an understanding of the design of various components).

S6.15.3 If the new frame is similar to last years, it is advisable to bring along evidence of the change (bringing along the old frame is not a bad idea).

APPENDIX S – 1 COST MODEL AND COST METHODOLOGY

1 Cost Models & Costing Methodology

The cost models are the underlying methodology and equations that relate the final cost of a part to the different operations and goods used in that part. These descriptions are accurate at the time of the rules publications. The models may be expanded as necessary based on evolving requirements.

2 Raw materials

- 2.1 Raw materials refer to the material stocks used to produce parts from scratch, such as billet steel for machining or aluminum ingot for casting. Bar, sheet and tube stock are purchased using raw material costs. The raw material purchased must include machining allowance. Standard allowances are given in 4.1 and must be used
- 2.2 Gross weight will refer to the weight of the raw material, including all machining stock
- 2.3 Net weight will refer to the weight of the finish machined part
- 2.4 Material costs are based on part gross weight. For example, a steel hub is machined from solid bar. The interior is removed by boring. The cost of the bar must include this interior material. Raw materials are normally cost by volume. A cost by weight is also given using an official density listed in the tables. Any parts that are weighed at competition to confirm cost will use the official density in calculating cost.

3 Assembly Labor

The assembly labor model is based on the following parameters:

- 3.1 Mass – The mass of the part influences the time it takes the operator to assemble the part to the assembly or vehicle. Light parts can be installed with one hand. Heavier parts require two hands and the heaviest parts need a lift assist apparatus. These factors are accounted for by selecting the appropriate entry from the process labor tables. The actual part mass must be equal to or less than the value selected. For example, a 300g part would have an assembly labor category of 1 kg.
- 3.2 Interfaces – The more interfaces a part has with the surrounding parts the longer it takes to assemble. Parts designed for minimal constraint are the easiest and cheapest to assemble.
- 3.3 Fit type – The ease with which a part can be assembled is described by the fit. There are three categories of fits:
 - 3.3.1 Loose – the part assembles with no force. Examples include a quick release steering wheel onto the steering shaft and a bracket bolted to a monocoque.
 - 3.3.2 Line on line – the part is designed to have a close fit to the surrounding parts and some buildup of force is required to get the part started. Examples include a rod end inserted between two tabs in double shear and a splined axle shaft into the differential gear.
 - 3.3.3 Interference – significant force is required to insert the part and mechanical assistance may be necessary. Examples include a rubber hose onto a barbed fitting and a ball bearing into a bore.

4 Machining

Costs for machining operations are based on the volume of material removed. The actual machine used, whether mill, lathe or otherwise, is the same unless a specific line item is included for that machine, such as gear hob.

NOTE: the machining model has been simplified from previous years. There are no longer rough and finish cuts nor near net shape processes.

- 4.1 All processes require a minimum of 1mm (0.040 inches) of machining stock to be removed from each surface of the part with machining.
- 4.7 The process multiplier for the material must also be used to calculate the total process cost of the operation. If a process multiplier is required, it will be listed in the processes table in the column labeled 'Multiplier Type Used'. If the column is blank for a process none is required.
- 4.8 When costing the raw materials that go into making machined parts the machine stock must be included in the purchased material mass, even though this material is machined away to produce the final part. This represents the cost of the purchased material. For example, an upright bore is machined into a piece of billet aluminum. The interior material that is milled away must be included in the billet mass and hence cost. The same feature machined into a casting need only include 1mm of machine stock of the machined away material
- 4.9 Machining requires labor operations to account for the time it takes an operator to fixture the part onto the machine. Every machined part requires at least a 'Machining Setup, Install and Remove' operation. This is the time it takes to pick up the work piece, fixture on the machine, and remove it when the machining is complete. For a part that requires an intermediate change in position, such as to machine the back of the part which would not be accessible in a single fixturing setup, the labor step of 'Machining Setup, Change' is also required. For example, an upright that requires three different orientations on a mill to fully machine would require two of the 'Machining Setup, Change' and the 'Machining Setup, Install and Remove' labor operations.
- 4.10 In certain cases, it is possible to fixture a work piece of raw material and machine more than one part out of it. For example, a self-feeding lathe could machine 10 suspension inserts out of a single piece of bar stock. In this case the quantity of the 'Machining Setup, Install and Remove' may be set to 0.1. This represents the 10 parts that can be machined per setup. This assumption should clearly be noted in the Cost Report along with enough details for the Cost Judges to verify the part geometry is appropriate for the machine being used.

5 Tooling & Fixturing

Tooling is necessary when certain processes are used. These can be identified in the tables because the tooling required will be indicated. Sometimes several types of tooling are available for the same process. Each has a description and an associated process with which it can be used. If a process has more than one tooling type associated with it the team must use the tooling that is closest to the actual tooling used in their prototype vehicle construction. Most tooling costs are independent of part shape, the assumption being that tooling for smaller parts will be built with multiple cavities to create an optimal cost effectiveness.

- 5.1 After calculating the total tooling cost for a part the cost must be divided by the Production Volume Factor (PVF) before being included in the Cost Report. The PVF represents the ability of the tooling to produce parts in volume production.

Production Volume Factor (PVF)

All parts not otherwise listed: 3000

Composite Monocoque (composite tub): 120

The following equation is used to calculate the tooling cost to be included for each part:

$$\text{Part Tooling Cost} = \frac{\text{Table Tooling Cost}}{\text{PVF} * \text{Number of Parts Using Exact Tooling}}$$

The tooling cost should be included with the appropriate part on the BOM. Tooling is not a separate section.

- 5.2 For example a cast aluminum upright uses a 2-piece sand core package. Total table price is \$5000 + \$5000 = \$10000. The team has designed the casting to be used for both the left and right hand rear corners. Calculating the Part Tooling Cost gives:

$$\text{Part Tooling Cost} = \frac{\$10000}{3000 * 2} = \$1.67 \text{ per upright}$$

The \$1.67 must be included as a line item on the Costed Bill of Material for each Upright.

- 5.3 Another example is a team is manufacturing a composite monocoque. The tub is constructed by building the top and bottom separately and bonding it together. Both the top and bottom use a two-piece composite tool and the cost of all four tools is \$45000. The PVF for tub tooling is only 120 because of the amount of time required to construct each tub so the tub Part Tooling Cost is:

$$\text{Part Tooling Cost} = \frac{\$45000}{120 * 1} = \$375 \text{ per tub}$$

6 Fastener Installation

The cost to tighten or loosen fasteners is based on the tool (or motion) needed to turn it, the diameter, length and whether the fastener requires a secondary tool for reacting the torque (such as a wrench on a nut).

- 6.1 Hand – When no tool is necessary for tightening, such as quick release fasteners or hand tightened nuts, the hand should be selected. Loose operations are those accomplished by using the fingers of the hand. If the entire hand is moving to rotate the fastener the tight category should be used.
- 6.2 Screwdriver – A tool that can be held in the hand and turned with the wrist. Any type of bit can be fitted such as straight, Philips, Torx, etc.
- 6.3 Wrench – An open-ended or box wrench or similar tool requiring motion of the hand. After a turn the wrench may have to be removed and repositioned for the next turn.
- 6.4 Ratchet – A tool with internal clutch that allows the hand to be moved and returned to the starting position without removal of the tool. Compatible with any bolt head style such as 6-point hex, 12-point hex, Torx or other.
- 6.5 Power Tool – An electric, pneumatic or other power assisted tool for running down fasteners. To qualify for power tool, use a fastener must meet the following requirements:
- 6.5.1 A socket of the size needed to drive the fastener must fit in the fully secured position
- 6.5.2 One power tool with minimum dimensions given in Appendix S-4 must fit onto the socket.

6.5.3 An extension may be used to fit the power tool but it may not exceed 0.35m in length.

6.6 Reaction Tool - In the case where the fastener is not being attached into the part but requires a nut or other separate threaded piece then a reaction tool will be required. This will appear as a separate line item and should appear whenever a nut is used on a bolt.

7 Composites

Composite manufacture is defined by following steps:

7.1 Laminate – Used to build the laminate one (1) ply at a time. A ply is a single layer of the laminate consisting of a single sheet of material, regardless of material or thickness. A ply may consist of woven carbon, unidirectional glass, adhesive film or honeycomb core, for example.

7.2 Curing Operations – Used to take a laminate and convert it to a finished composite structure. All curing operations include vacuum bagging, peel ply, breather cloth and other consumable materials and labor. Costs also include part removal from the mold.

7.2.1 Room temperature cure – used for room temperature curing resin systems.

7.2.2 Oven cure – used for higher temperature cure cycles for composites. Limited to one (1) atmosphere of external pressure.

7.2.3 Autoclave cure – used for high temperature and pressure composites curing.

7.3 Curing operations require tooling. Tooling must reflect the type of tooling actually used (composite, aluminum, steel, etc.).

7.4 If hybrid weaves are used the cost can reflect the ratio of the materials in the ply. For example, a 50% carbon fiber, 50% glass woven ply may use the average cost of the carbon and glass materials. If the actual fiber ratio is not used, then the cost of the ply must be the cost of the highest cost material present.

7.5 When costing composite materials, the total mass of the part in the Cost Report must match the actual mass of the part as presented on the vehicle for Cost Judging. The composite material, whether carbon fiber or other must be the cost of both the fiber and resin together. This is true for both prepreg and dry fiber systems and is further stated in the Materials Table. The mass of each ply can be adjusted to make the finish part mass match the Cost Report. Parts can be weighed during judging and the Cost Report mass must be equal to or greater than the actual mass of the part, even including clear coat, paint and other finishes. **NOTE:** The paint mass is being included to avoid debates in Cost Judging about how much weight the paint (or clear coat) has added. The cost of the paint and paint application need not be included if it is solely for cosmetic purposes (see S4.23.1) but the mass of paint must be included in the composite cost.

8 Electronics and Wiring

The wiring harness is cost as a number of connectors of a certain style, each interconnected by a number of wires of a certain type. The electrical system is composed of three wiring types.

8.1 Signals - Inputs to the control system such as wheel speed, mass airflow or the position of a driver toggle switch.

8.2 Controls - Control system outputs. These can be digital signals, pulse width modulated or voltage outputs.

- 8.3 Power - Wires carrying current for vehicle distribution or actuators. These include vehicle power from the battery, engine starter, solenoids, motors etc.
- 8.4 Additionally, the following terms will be used for the Cost Tables:

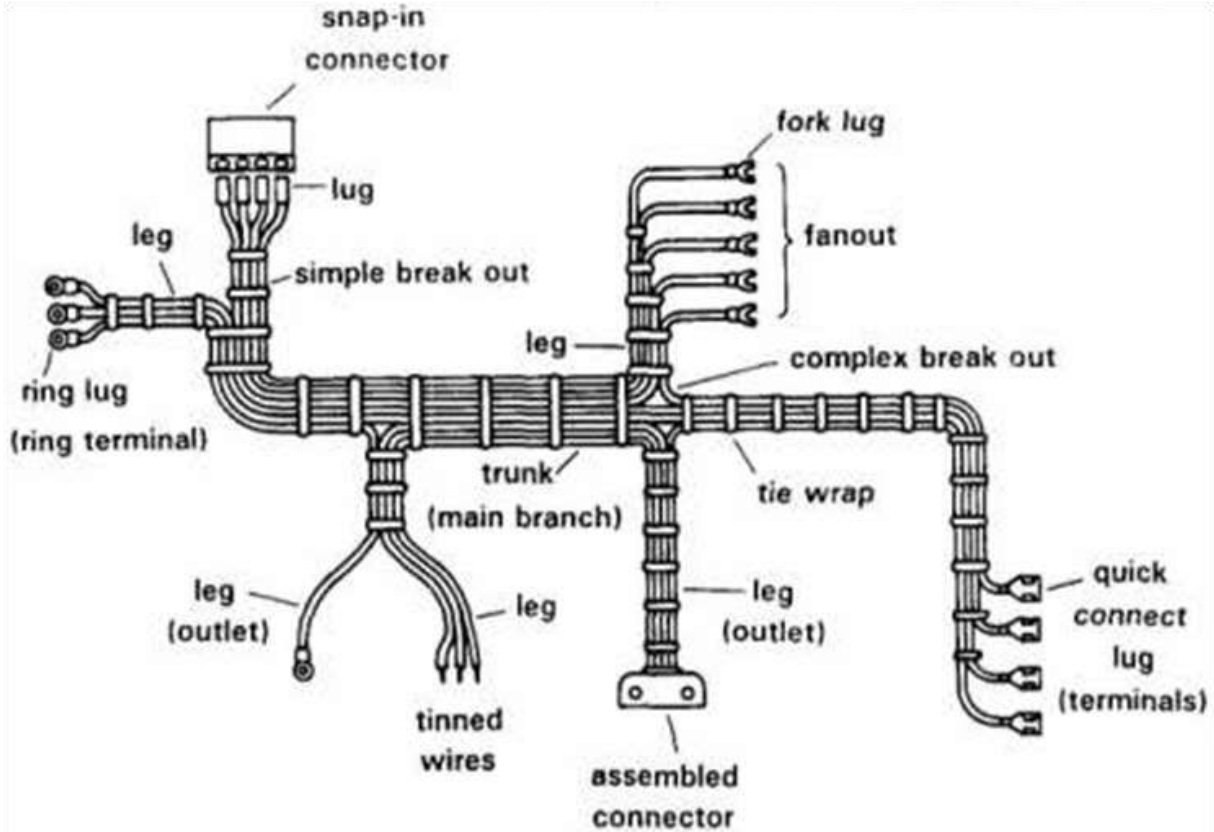

Figure E-1.1
 From “Product Design for Manufacture & Assembly” by Geoffrey Boothroyd, 1994.

APPENDIX S – 2 STANDARD PART NUMBERING

- 1 All assemblies and parts in the BOM must have a part number using the following convention:
Competition Code – Date Code - Car Number – System Designation – Base Number – Suffix
 - 1.1 Competition Code – A code for the competition entered. Refer to A2.6.
 - 1.2 Date Code – Last two digits of the year of the event.
 - 1.3 Car Number – A three (3) digit number assigned to the car for the specific event
 - 1.4 System Designation – A two (2) letter code for the system under which the part is associated. These can be found in Appendix S-3.
 - 1.5 Base Number – Five (5) digit numbers assigned at the student’s discretion. For assemblies this becomes a four (4) digit number with preceding character of “A”.
 - 1.6 Suffix – Two-character code showing part change history. These are provided for student use only so if desired all can be “AA”.
 - 1.6.1 First character refers to the part design revision level.
 - 1.6.2 Second character refers to the part process revision level.
 - 1.7 For example, a part entered into the chassis section for car number 27 competing at an event with code “FSAEM” that the students have decided is part one would be:
FSAEM – 08 – 027 – CH – 00001 – AA
 - 1.8 The same part, after significant design changes would become:
FSAEM – 08 – 027 – CH – 00001 – BA

The differential assembly that the students have decided is the third assembly for the Engine & Drivetrain group would be:
FSAEM – 08 – 027 – EN – A0003 – AA
 - 1.9 In the printed version of the Cost Report the competition code, date and car number fields of the part numbers do not need to be printed. They do need to be included in the digital files submitted. The event code and car numbers are for SAE use when the different digital files are combined into the master database.
- 2 All fasteners in the BOM must have a part number using the same convention as parts. All fasteners use system code “FS” even though they are included in the BOM under the part and assembly where they are used.



APPENDIX S – 3 ORGANIZED LIST OF SYSTEMS & ASSEMBLIES

Appendix S-3 is posted at www.fsaonline.com.

APPENDIX S – 4 POWER TOOL PACKAGE ENVELOPES

Appendix S-4 is posted at www.fsaonline.com.



APPENDIX S – 5 FSAE COST EVENT ADDENDUM

School: _____ **Car Number:** _____

(Please indicate decreases using bracketed numbers.)

	Section	Original Reported Total	New Reported Total	Difference	Cost Judge Initials
1					
2					
3					
4					
5					
6					
7					
8					

TOTAL VEHICLE

Summary of differences listed above.
fully detailed Costed Bill of Material for
changes.

\$	\$	\$
----	----	----

Attach

1
2
3
4
5
6
7
8

Accepted by: _____	Entered by: _____
Date: _____	Date/Time: _____

Addendums will be accepted only at the time of registration on-site at the competition!

These forms will then be forwarded to the cost judges the morning of the cost event.



APPENDIX S – 6 PRESENTATION JUDGING

The Presentation Judging Score Sheet is posted at www.fsaonline.com

APPENDIX S – 7 DESIGN JUDGING

The Design Event Score Sheet is posted at www.fsaonline.com

Teams are advised to thoroughly read all the documents related to the Design Event that are posted at www.fsaonline.com.

2017-18 FORMULA SAE RULES PART D - DYNAMIC EVENT REGULATIONS

ARTICLE 1: DYNAMIC EVENTS AND MAXIMUM SCORES

The maximum scores in the dynamic events are:

Acceleration	100 points
Skid Pad	75 points
Autocross	125 points
Efficiency	100 points
<u>Endurance</u>	<u>275 points</u>
Total	675 points

D1.1 **Vehicle Integrity and Disqualification**

D1.1.1 During the Dynamic Events, the mechanical integrity of the vehicle must be maintained.

D1.1.2 Any vehicle condition that could compromise vehicle integrity, or could compromise the track surface or could pose a potential hazard to participants, e.g. damaged suspension, brakes or steering components, fluid leaks, dragging bodywork, lost or loose body panels, or a malfunctioning brake light will be a valid reason for exclusion by the official until the problem is rectified.

NOTE: If this happens during the Endurance Event, it means disqualification from the heat.

D1.2 **Access to Dynamic Events and Working on Vehicles in Dynamic Events areas**

D1.2.1 The respective competition organizers may choose to specify areas of the event such as the waiting area for dynamic events where only team members wearing dynamic passes may gain access and the number of tools that may be used in this area may be restricted. Please check the respective event websites or event handbooks to understand the specific restrictions for any competition.

D1.2.2 The respective competition organizers may choose to specify areas of the event such as the area immediately prior to the start line for dynamic events where no team members except the driver in the car may enter. The marshals may grant permission for team members at their discretion to recover cars from this area in the event that a car stalls or breaks down however it is likely that no tools including auxiliary starter batteries may be used in this area. Please check the respective event websites or event handbooks to understand the specific restrictions for any competition.

ARTICLE 2: WEATHER CONDITIONS

The organizer reserves the right to alter the conduct and scoring of the competition based on weather conditions.

ARTICLE 3: RUNNING IN RAIN

D3.1 **Operating Conditions**

The following operating conditions will be recognized at Formula SAE:

D3.1.1 Dry – Overall the track surface is dry.

D3.1.2 Damp – Significant sections of the track surface are damp.

- D3.1.3 Wet – The entire track surface is wet and there may be puddles of water.
- D3.1.4 Weather Delay/Cancellation – Any situation in which all, or part, of an event is delayed, rescheduled or canceled in response to weather conditions.
- D3.2 **Decision on Operating Conditions**
The operating condition in effect at any time during the competition will be decided by the competition officials.
- D3.3 **Notification**
If the competition officials declare the track(s) to be "Damp" or "Wet",
 - This decision will be announced over the public address system, and
 - A sign with either "Damp" or "Wet" will be prominently displayed at either the starting line(s) or the start-finish line of the event(s), and the entry gate to the "hot" area.
- D3.4 **Tire Requirements**
The operating conditions will determine the type of tires a car may run as follows:
- D3.4.1 Dry – Cars must run their Dry Tires, except as covered in Rule D3.8.2.
- D3.4.2 Damp – Cars may run either their Dry Tires or Rain Tires, at each team's option.
- D3.4.3 Wet – Cars must run their Rain Tires.
- D3.5 **Event Rules**
All event rules remain in effect.
- D3.6 **Penalties**
All penalties remain in effect.
- D3.7 **Scoring**
No adjustments will be made to teams' times for running in "Damp" or "Wet" conditions. The minimum performance levels to score points may be adjusted if deemed appropriate by the officials.
- D3.8 **Tire Changing**
- D3.8.1 During the Acceleration, Skid-Pad or Autocross Events:
Within the provisions of Rule D3.4 above, teams may change from Dry Tires to Rain Tires or vice versa at any time during those events at their own discretion.
- D3.8.2 During the Endurance Event:
Teams may change from Dry to Rain Tires or vice versa at any time while their car is in the staging area inside the "hot" area.
- All tire changes after a car has received the "green flag" to start the Endurance Event must take place in the Driver Change Area.
- If the track was "Dry" and is declared "Damp":
 - Teams may start on either Dry or Rain Tires at their option.
 - Teams that are on the track when it is declared "Damp", may elect, at their option, to pit in the Driver Change Area and change to Rain Tires under the terms spelled out below in "Tire Changes in the Driver Change Area".
 - If the track is declared "Wet":

- A Red Flag will be shown at the Start/Finish Line and all cars will enter the Driver Change Area.
 - Those cars that are already fitted with "Rain" tires will be allowed re-start without delay subject to the discretion of the Event Captain/Chief Marshall.
 - Those cars without "Rain" tires will be required to fit them under the terms spelled out below in "Tire Changes in the Driver Change Area". They will then be allowed to re-start at the discretion of the Event Captain/Chief Marshall.
- (c) If the track is declared "Dry" after being "Damp" or "Wet":
- The teams will NOT be required to change back to "Dry" tires.
- (d) Tire Changes at Team's Option:
- Within the provisions of Rule D3.4 above and Rule D3.8.2 (b) above, a team will be permitted to change tires at their option.
 - If a team elects to change from "Dry" to "Rain" tires, the time to make the change will NOT be included in the team's total time.
 - If a team elects to change from "Rain" tires back to "Dry" tires, the time taken to make the change WILL be included in the team's total time for the event, i.e. it will not be subtracted from the total elapsed time. However, a change from "Rain" tires back to "Dry" tires will not be permitted during the driver change.
 - To make such a change, the following procedure must be followed:
 - Team makes the decision,
 - Team has tires and equipment ready near Driver Change Area,
 - The team informs the Event Captain/Chief Marshall they wish their car to be brought in for a tire change,
 - Officials inform the driver by means of a sign or flag at the checker flag station,
 - Driver exits the track and enters the Driver Change Area in the normal manner.
- (e) Tire Changes in the Driver Change Area:
- Per Rule D8.12, no more than three people for each team may be present in the Driver Change Area during any tire change, e.g. a driver and two crew or two drivers and one crew member.
 - No other work may be performed on the cars during a tire change.
 - Teams changing from "Dry" to "Rain" tires will be allowed a maximum of ten (10) minutes to make the change.
 - If a team elects to change from "Dry" to "Rain" tires during their scheduled driver change, they may do so, and the total allowed time in the Driver Change Area will be thirteen (13) minutes.
 - The time spent in the driver change area of less than 10 minutes without driver change, or 13 minutes with driver change, will not be counted in the team's total time for the event. Any time in excess of these times will be counted in the team's total time for the event.

ARTICLE 4: DRIVER LIMITATIONS

D4.1 Three Event Limit

An individual team member may not drive in more than three (3) events.

D4.1.1 The Efficiency Event is considered a separate event although it is conducted simultaneously with the Endurance Event.

D4.2 **Single Heat Limit**

An individual may not drive in both heats of any event. It is the team's option to participate in any event.

D4.2.1 The team may forfeit their second heat in any performance event.

NOTE: At competitions where Endurance and Efficiency is run with one (1) heat a minimum of four (4) drivers are required to participate in all heats of the dynamic events. At competitions where Endurance and Efficiency is run with two (2) heats a minimum of five (5) drivers are required to participate in all heats of the dynamic events.

ARTICLE 5: ACCELERATION EVENT

D5.1 **Acceleration Objective**

The acceleration event evaluates the car's acceleration in a straight line on flat pavement.

D5.2 **Acceleration Procedure**

Course Layout – The acceleration course length will be 75 m (82 yards) from starting line to finish line. The course will be at least 4.9 m (16 ft.) wide as measured between the inner edges of the bases of the course edge cones. Cones are placed along the course edges at intervals of about 5 paces (roughly 20 feet). Cone locations are not marked on the pavement.

D5.2.1 Staging - The foremost part of the car will be staged at 0.30 m (11.8 inches) behind the starting line. Cars will accelerate from a standing start.

D5.2.2 Starting - A green flag will be used to indicate the approval to begin, however, timing starts only when the vehicle crosses the starting line as measured by the timing system.

D5.2.3 Second Run Option - A driver has the option to make a second run immediately after his/her first run.

D5.3 **Acceleration Heats**

D5.3.1 There will be two (2) heats. Each heat must have a different driver and each driver may have two (2) runs.

D5.3.2 Starting order will be based upon time of arrival to the staging area.

D5.3.3 Heat one (1) and heat two (2) will not be run sequentially, but simultaneously. Heat 1 drivers will have starting priority over heat 2 drivers.

D5.4 **Tire Traction – Limitations**

Special agents that increase traction may not be added to the tires or track surface and “burnouts” are not allowed.

D5.5 **Acceleration Scoring**

The acceleration score is based upon the corrected elapsed time. Elapsed time will be measured from the time the car crosses the starting line until it crosses the finish line.

D5.6 **Acceleration Penalties**

D5.6.1 Cones Down or Out (DOO)

A two (2) second penalty will be added for each DOO (including entry and exit gate cones) that occurred on that particular run to give the corrected elapsed time.

D5.6.2 Off Course

An Off Course (OC) will result in a DNF for that run.

D5.7 Did Not Attempt

Cars that have not run by the end of the event (determined by the organizer) will receive a Did Not Finish (DNF).

D5.8 Acceleration Scoring Formula

D5.8.1 The following equation is used to determine the scores for the event:

$$\text{ACCELERATION SCORE} = 95.5 \times \frac{(\text{Tmax} / \text{Tyour}) - 1}{(\text{Tmax} / \text{Tmin}) - 1} + 4.5$$

Where:

Tyour is the best corrected elapsed time for the team including penalties.

Tmin is the elapsed time of the fastest car.

Tmax is 150% of Tmin

D5.8.2 In the above equation, the first term on the right hand side is “performance” points”, while the second term represents “completion points,” or the minimum score for having successfully completed the event.

DNF = zero (0) points

ARTICLE 6: SKID-PAD EVENT

D6.1 Skid-Pad Objective

The objective of the skid-pad event is to measure the car’s cornering ability on a flat surface while making a constant-radius turn.

D6.2 Skid-Pad Heats

D6.2.1 Each car may compete in two heats. Each heat must have a different driver, and each driver may have two (2) runs.

D6.2.2 Two separate skid-pad locations may exist. If there are two (2) skid-pads, one driver must make both his runs on one skid-pad (Skid-Pad 1) and the other driver must make both his runs on the other skid-pad (Skid-Pad 2).

D6.2.3 If there is only one skid-pad location, then both Heat one (1) and Heat two (2) will be run on the same skid-pad.

D6.3 Skid-Pad Heat Priority

There will be no distinction between Heat one (1) and Heat two (2) and there will be no particular starting order. Heat one (1) drivers will have a starting priority over Heat two (2) drivers. Cars which have not run by the event closing (determined by the organizer) will receive a DNF for the event.

D6.4 Skid-Pad Layout

There will be two (2) pairs of concentric circles in a figure of eight pattern. The centers of these circles will be 18.25 m (59.88 feet) apart. The inner circles will be 15.25 m (50.03 feet) in diameter, and the outer circles will be 21.25 m (69.72 feet) in diameter. The driving path will be the 3.0 m (9.84 feet) path between the inner and outer circles. The cars will enter and exit through gates on a 3.0 m wide path that is tangential to the circles where they meet.

The line between the centers of the circles defines the start/stop line. A lap is defined as traveling around one (1) of the circles from the start/stop line and returning to the start/stop line.

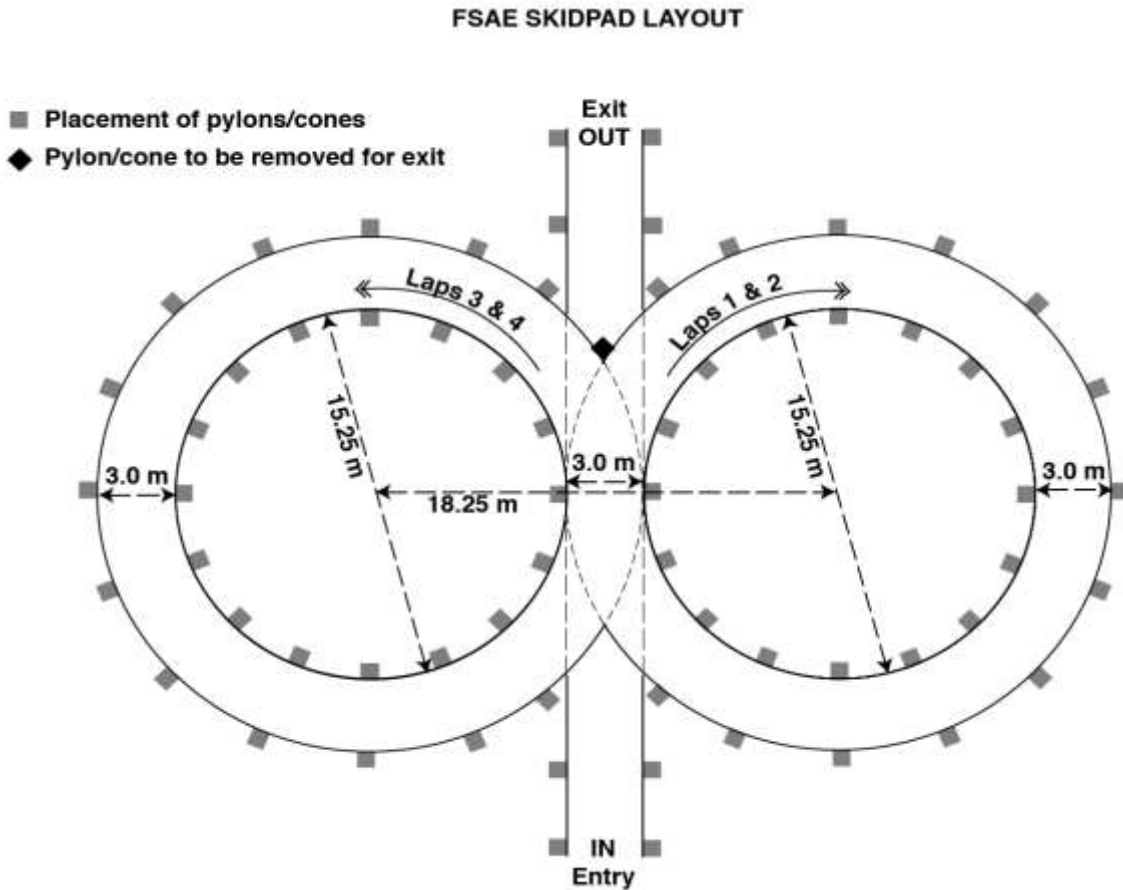

D6.5 Skid-Pad Layout – Marking

D6.5.1 Sixteen (16) pylons will be placed around the inside of each inner circle thirteen (13) pylons positioned around the outside of each outer circle in the pattern shown in the FSAE skid pad layout diagram.

D6.5.2 Each circle will be marked with a chalk line, inside the inner circle and outside the outer circle, i.e. not on the driving path.

D6.5.3 Additional pylons will establish the required entry and exit gates. Also, a cone will be placed in the middle of the exit gate to prevent unintended exits until the finish lap.

NOTE: The diagram in section D6.4 shows the circles for cone placement, not for course marking. Chalk lines are marked on the opposite side of the cones, i.e. not in the driving path.

D6.6 Skid-Pad Procedure

The cars will enter perpendicular to the figure eight and will take one full lap on the right circle to establish the turn. The next lap will be on the right circle and will be timed. Immediately following the second lap, the car will enter the left circle for the third lap. The fourth lap will be on the left circle and will be timed. Immediately upon finishing the fourth lap, the car will exit the track. The car will exit at the intersection moving in the same direction as entered. A driver has the option to take a second run immediately after the first.

D6.7 Skid-Pad Penalties

The elapsed time for the right and left circle will be averaged together after the following penalties have been assessed.

D6.7.1 Cones Down Or Out (DOO)

A penalty of 0.25 seconds will be added to the time for every cone that is knocked “down or out” (including gate cones).

D6.7.2 Off Course

Cars that spin-out may continue as long as they have not gone off course. Cars going off course will be classified as DNF.

D6.7.3 Incorrect Laps

Cars that do not follow D6.6 above, i.e. run an incorrect number of laps or run the laps in the wrong sequence will be classified as DNF.

D6.8 Skid-Pad Scoring

D6.8.1 The skid-pad score is computed for the team’s best run from the average of the left and right timed laps including penalties.

D6.8.2 If there are two separate skid-pad locations, then the score will be based on the best run from either skid-pad.

D6.8.3 The following equation is used to determine the scores for the skid-pad event:

$$\text{SKID PAD SCORE} = 71.5 \times \frac{(\text{Tmax} / \text{Tyour})^2 - 1}{(\text{Tmax} / \text{Tmin})^2 - 1} + 3.5$$

Where:

Tyour is determined as: (Right lap time + Left lap time + (Cones * 0.25 sec)) / 2

Tmin is the lowest corrected average time recorded for any competitor

Tmax is 125% of Tmin

D6.8.4 The first term on the right-hand side of the equation represent “performance points,” while the second term represents “completion points,” or the minimum score for having successfully completed the event.

D6.8.5 Negative “performance” points will not be given. However, 3.5 points will be given for a car that completes a run, even if Tyour exceeds 125% of the fastest time (Tmin).

ARTICLE 7: AUTOCROSS EVENT

D7.1 Autocross Objective

The objective of the autocross event is to evaluate the car's maneuverability and handling qualities on a tight course without the hindrance of competing cars. The autocross course will combine the performance features of acceleration, braking, and cornering into one event.

D7.2 Autocross Course Specifications & Speeds

D7.2.1 The following standard specifications will suggest the maximum speeds that will be encountered on the course. Average speeds should be 40 km/hr (25 mph) to 48 km/hr (30 mph).

NOTE: the actual average speed for any track will depend on the prevailing conditions and the area available to the organizers in which the track is setup, therefore the quoted speeds are intended as a rough guide only.

Straights: No longer than 60 m (200 feet) with hairpins at both ends (or) no longer than 45 m (150 feet) with wide turns on the ends.

Constant Turns: 23 m (75 feet) to 45 m (148 feet) diameter.

Hairpin Turns: Minimum of 9 m (29.5 feet) outside diameter (of the turn).

Slaloms: Cones in a straight line with 7.62 m (25 feet) to 12.19 m (40 feet) spacing.

Miscellaneous: Chicanes, multiple turns, decreasing radius turns, etc. The minimum track width will be 3.5 m (11.5 feet).

D7.2.2 The length of each run will be approximately 0.805 km (1/2 mile) and the driver will complete a specified number of runs.

D7.2.3 The organizers reserve the right to run the Autocross Event on courses of different length.

D7.2.4 The organizers reserve the right to deviate from the parameters specified in this rule, D7.2, when they determine it is appropriate given the characteristics of a particular competition site.

D7.3 Autocross Procedure

D7.3.1 There will be two (2) Autocross-style heats, with each heat having a different driver. Two (2) timed laps will be run (weather and time permitting) by each driver and the best lap time will stand as the time for that heat.

D7.3.2 Starting order will be based upon time of arrival to the staging area.

D7.3.3 Heat one (1) and heat two (2) will not be run sequentially, but simultaneously. Heat 1 drivers will have starting priority over heat 2 drivers. A driver has the option to take a second run immediately after the first run.

D7.3.4 The car will be staged such that the front wheels are 6 m (19.7 feet) behind the starting line. The timer starts only after the car crosses the start line.

D7.3.5 The organizer will determine the allowable windows for each heat and retains the right to adjust for weather or technical delays. Cars that have not run by the end of the heat will be disqualified for that heat.

D7.4 Autocross Penalties

The cars are judged on elapsed time plus penalties. The following penalties will be added to the elapsed time:

D7.4.1 Cone Down or Out (DOO)

Two (2) seconds per cone, including any after the finish line.

D7.4.2 Off Course (OC)

- a. An “off course” occurs when the vehicle has all four (4) wheels outside the course boundary as indicated by (a) cones, (b) edge marking or (c) the edge of the paved surface. Where more than one boundary indicator is used on the same course, at any given point the narrowest track will be used when determining off course penalties.
- b. When an OC occurs, the driver must reenter the track at or prior to the point of exit or a twenty (20) second penalty will be assessed.
- c. Two (2) wheels off will not incur an immediate penalty. However, repeated driving of this type is cause for a black flag.
- d. Penalties will not be assessed for accident avoidance or other reasons deemed sufficient by the track officials.

D7.4.3 Missed Slalom

Missing one or more gates of a given slalom will be counted as one "off-course" per occurrence. Each occurrence will incur a twenty (20) second penalty.

D7.5 Stalled & Disabled Vehicles

D7.5.1 If a car stalls and cannot restart without external assistance, the car will be deemed disabled.

D7.5.2 Disabled cars are scored DNF for that attempt.

D7.5.3 Disabled cars will be cleared from the track by the track workers. At the direction of the track officials team members may be instructed to retrieve the vehicle. Vehicle recovery may only be done under the control of the track officials.

D7.6 Corrected Elapsed Time

D7.6.1 The elapsed time plus any penalties from that specific run will be used as the corrected elapsed time.

D7.6.2 Cars that are unable to complete the course with an average speed of 69% of the fastest car will not be awarded “performance” points. This means that any autocross time in excess of 145% of the fastest time will receive no “performance” points.

D7.7 Best Run Scored

The time required to complete each run will be recorded and the team’s best corrected elapsed time will be used to determine the score.

D7.8 Autocross Scoring Formula

D7.8.1 The following equation is used to determine the autocross score:

$$\text{AUTOCROSS SCORE} = 118.5 \times \frac{(T_{\text{max}} / T_{\text{your}}) - 1}{(T_{\text{max}} / T_{\text{min}}) - 1} + 6.5$$

Where:

T_{min} is the lowest corrected elapsed time recorded for any competitor in either heat

T_{max} is 145% of T_{min}

T_{your} is the lowest corrected elapsed time in either heat for the team being scored.

- D7.8.2 In the equation above, the first term on the right hand side represents “performance” points, while the second term, or “completion” points represents the minimum score for having successfully completed the event.
- D7.8.3 Negative “performance” points will not be given. However, 6.5 points will be given for a car that completes a run, even if T_{your} exceeds 145% of the fastest time (T_{min})

ARTICLE 8: ENDURANCE AND EFFICIENCY

- D8.1 At Formula SAE competitions in North America the Endurance & Efficiency event will consist of a single heat. For competitions outside North America please check the event website.
- D8.2 **Driver Eligibility**
The Endurance and Efficiency are separate events even though they are run simultaneously. Therefore, anyone driving in a heat of Endurance and Efficiency uses two (2) driving eligibilities. (See ARTICLE 4: “Driver Limitations”)
- D8.3 **Right to Change Procedure**
This Article, D8, contains the general guidelines for conducting the Endurance and Efficiency event, however, the organizers reserve the right to establish procedures specific to the conduct of the event at each competition site. All such procedures will be made known to the teams through email or the specific FSAE competition news page website.
- D8.4 **Endurance Objective**
The Endurance Event is designed to evaluate the overall performance of the car and to test the car’s durability and reliability.
- D8.5 **Efficiency**
The car’s efficiency will be measured in conjunction with the Endurance Event. The efficiency under competition conditions is important in most vehicle competitions and also shows how well the car has been tuned for the competition. This is a compromise event because the efficiency score and endurance score will be calculated from the same heat. No refueling will be allowed during an endurance heat.
- D8.6 **Endurance Course Specifications & Speeds**
D8.6.1 Course speeds may be estimated by the following standard course specifications. Average speed should be 48 km/hr (29.8 mph) to 57 km/hr (35.4 mph) with top speeds of approximately 105 km/hr (65.2 mph).

NOTE: the actual average speed for any track will depend on the prevailing conditions and the area available to the organizers in which the track is setup, therefore the quoted speeds are intended as a rough guide only.

D8.6.2 The standard specifications for the FSAE Endurance Course are:

Straights: No longer than 77.0 m (252.6 feet) with hairpins at both ends (or) no longer than 61.0 m (200.1 feet) with wide turns on the ends. There will be passing zones at several locations.

Constant Turns: 30.0 m (98.4 feet) to 54.0 m (177.2 feet) diameter.

Hairpin Turns: Minimum of 9.0 m (29.5 feet) outside diameter (of the turn).

Slaloms: Cones in a straight line with 9.0 m (29.5 feet) to 15.0 m (49.2 feet) spacing.

Miscellaneous: Chicanes, multiple turns, decreasing radius turns, etc. The standard minimum track width is 4.5 m (14.76 feet).

D8.6.3 The organizers reserve the right to deviate from the parameters specified in this rule, D8.6, when they determine it is appropriate given the characteristics of the particular competition site.

D8.7 **Endurance General Procedure**

D8.7.1 The event will be run as a single heat approximately 22 km (13.66 miles) long.

D8.7.2 Teams are not allowed to work on their vehicles during the heat.

D8.7.3 A driver change must be made during a three (3) minute period at the midpoint of the heat.

D8.7.4 Wheel-to-wheel racing is prohibited.

D8.7.5 Vehicles must not be driven in reverse

D8.7.6 Passing another vehicle may only be done in an established passing zone or under control of a course marshal.

D8.7.7 Elapsed time will begin when Driver A enters the course and crosses the timing line.

D8.8 **Endurance Run Order**

D8.8.1 The endurance run order is established so that cars of similar speed potential are on track together to reduce the need for passing.

D8.8.2 Each competition may establish conditions for teams to compete in the endurance event.

D8.8.3 The endurance run order should be based on the autocross event finish order, and include the teams eligible for endurance which did not compete in the autocross event.

D8.8.4 The run order sequence may be altered by the organizer to accommodate specific circumstances or event considerations.

D8.8.5 Teams must keep track of the run order and have their cars fueled, in line and prepared to start when their turn to run arrives.

D8.8.6 Teams that are not ready-to-run when their turn arrives will be penalized two (2) minutes and may then run at the discretion of the event captain.

- D8.9 Endurance Fuel Fill – IC cars**
Before entering the event each vehicle’s fuel tank must be filled to the fuel level line (see Rule IC2.6.6, “Fuel Level Line”) at the fueling station. During fueling, once filled to the scribe line, no shaking or tilting of the tank or fuel system (incl. entire vehicle) is allowed.
- D8.10 Endurance Charging – EVs**
Before entering the event, the vehicles may be fully charged and an energy meter will be fitted to log the electrical energy that is used.
- D8.11 Endurance Vehicle Starting/ Restarting**
- D8.11.1** The vehicle must be capable of starting / restarting without external assistance at all times once the vehicle has begun the heat. A vehicle will have been considered to have started the heat either after it has been requested to approach the start line or after it has crossed a line as defined in D1.2.2
- D8.11.2** If a vehicle stalls out on the track, it will be allowed one (1) lap by the car that is following it (approximately one (1) minute) to restart.
- D8.11.3** If a vehicle has a restart problem after the driver has been changed or after a red flag, it will be allowed two (2) minutes to restart the engine or to enable the tractive system. The two (2) minutes will start from the time that the driver first tries to restart the engine or to enable the tractive system. The two (2) minutes is not counted towards the endurance time and is measured independently from the time allowed to change the driver.
- D8.11.4** If restarts are not accomplished within the above times, the car will be deemed disabled and scored DNF for the heat.
- D8.12 Endurance Driver Change Procedure**
- D8.12.1** Three (3) minutes are allowed for the team to change drivers.
- D8.12.2** Only three (3) team members, including the driver or drivers, will be allowed in the driver change area, and only the tools necessary adjust the car to accommodate the second driver and/or change tires will be carried into this area (no tool chests etc.). Extra people entering the driver change area will result in a twenty-point (20 pt) penalty to the final endurance score for each extra person entering the area.
- D8.12.3** For electric cars, the three (3) team members must consist of an ESO and two drivers.
- D8.12.4** Other than changes to accommodate the second driver or covered by D3.8.2 “Tire Changing” and operating the master switch(es), the team is not permitted to perform any work on the car during Driver Change.
- D8.12.5** Driver A will drive for 11 km (6.83 miles), and then be signaled into the driver change area.
- D8.12.6** Once stopped in the driver change area, Driver A will turn off the engine for IC vehicles or turn off the tractive system for EVs.
- D8.12.7** Driver A will exit the vehicle and any necessary adjustments will be made to the vehicle to fit Driver B (seat cushions, head restraint, pedal position, etc.). Driver B will then be secured in the vehicle.
- D8.12.8** Driver B will drive for 11 km (6.83 miles) and elapsed time will stop when the car completes the total 22 km (13.66 miles) distance.

- D8.12.9 For IC engine cars, Driver B will proceed directly to the fueling station. The tank will be filled to refill mark and the amount will be recorded
- D8.12.10 For EVs, Driver B will proceed directly to the EV data download area where the data will be downloaded and the energy that was used will be calculated.
- D8.12.11 The driver change area will be placed such that the timing system will see the driver change as an extra-long lap which will be deleted from the total time. The time taken to change the driver will be timed. If the driver change takes longer than three (3) minutes, the extra time will be counted into the final time.
NOTE: If the officials determine that any further adjustments are required to correctly fit the driver, the additional time will not be counted against the team.

D8.13 **Entering the Track**

- D8.13.1 Cars will be allowed to enter the track based upon the level of traffic on the course.
- D8.13.2 The number of vehicles simultaneously on the course depends on the track length and design as well as the operating conditions. In dry conditions, there are typically 5 to 7 vehicles allowed per kilometer of track. This includes cars in the driver change area.
- D8.13.3 Because repairs are not allowed during the heat, and there will be no refueling during the heat, there will not be a restart queue of any kind.

D8.14 **Breakdowns & Stalls**

- D8.14.1 If a vehicle breaks down it will be removed from the course and will not be allowed to re-enter the course.
- D8.14.2 If a vehicle stalls, or ingests a cone, etc., it will be allowed to restart (See D8.10 “Endurance Vehicle Starting/Restarting”) and re-enter the course where it went off, but no work may be performed on the vehicle.
- D8.14.3 If a car stalls and cannot be restarted without external assistance, the track workers will push the car clear of the track. At the discretion of event officials, two (2) team members may retrieve the car under direction of the track workers.

Comment – Teams are reminded that although course crews exercise due care, the organizers are not responsible for any damage that may occur when moving a disabled vehicle. Please consider the comment to Rule T6.6 “Jacking Point”.

D8.15 **Endurance Minimum Speed Requirement**

- D8.15.1 If a car is unable to maintain lap times within one hundred forty-five percent (145%) of the fastest lap time for the course, then it must exit immediately.
- D8.15.2 Disqualification for failure to maintain the minimum speed will be made at the discretion of the Chief Marshall/Director of Operations.

D8.16 **Post Event Refueling**

Vehicles must power down after leaving the course and be pushed to the fueling area for IC cars or EV data download area for EVs

For IC cars, Fuel pumps will be turned on and fuel valves will be opened to insure complete refueling.

- D8.16.1 Should the fuel level change after refueling due to effects such as described in IC2.7.1 then the difference in fuel level will be measured and twice the amount will be added to the official fuel consumption figure.
- D8.17 Endurance Lap Timing**
- D8.17.1 Each lap of the endurance event will be individually timed either by electronic means, or by hand.
- D8.17.2 The corrected Endurance time for an individual heat will be determined by subtracting the extra-long lap for the driver change, and the time taken for any stops under a mechanical black flag, from the total time.
- D8.17.3 The scored Endurance time for an individual heat will be the corrected time plus any penalty times.
- D8.18 Endurance Penalties**
- D8.18.1 Penalties will not be assessed for accident avoidance or other reason deemed sufficient by the track official.
- D8.18.2 The penalties in effect during the Endurance Event are listed below.
- D8.18.3 Cones
Cone down or out (DOO) = two (2) seconds per cone. This includes cones before the start line and after the finish line.
- D8.18.4 Off Course (OC)
- An “off course” occurs when the vehicle has all four (4) wheels outside the course boundary as indicated by (a) cones, (b) edge marking or (c) the edge of the paved surface. Where more than one boundary indicator is used on the same course, at any given point the narrowest track will be used when determining off course penalties.
 - When an OC occurs, the driver must reenter the track at or prior to the point of exit or a twenty (20) second penalty will be assessed.
 - Two (2) wheels off will not incur an immediate penalty. However, repeated driving of this type is cause for a black flag.
- D8.18.5 Missed Slalom
Missing one or more gates of a given slalom will incur a twenty (20) second penalty.
- D8.18.6 Penalties for Moving Violations
The following are penalties and assessed times or disqualifications for moving violations:
- Failure to obey a flag: 1 minute
 - Over Driving (After a closed black flag): 1 Minute
 - Vehicle to Vehicle contact: 2 Minutes up to disqualification depending on the nature of the incident.
- D8.18.7 Out of Order
Running out of order – two (2) minute penalty.
- D8.18.8 Mechanical Problem
No time penalty. The time taken for mechanical inspection under a “mechanical black flag” is considered officials’ time and is not included in the teams’ total time. However, if the inspection reveals a mechanical integrity problem the vehicle may be disqualified under Rule D1.1 “Vehicle Integrity and Disqualification”. If the car has a tire puncture, the team may opt to change the wheel and tire for an identical wheel and tire. In cases where the puncture is caused by track debris and not

a result of the component failure on the vehicle, the time will not count towards the team's total time. Tires must be changed in the driver change area.

D8.18.9 Reckless or Aggressive Driving

Any reckless or aggressive driving behavior (such as forcing another car off the track, refusal to allow passing, or close driving that would cause the likelihood of car contact) will result in a black flag for that driver. The driver must proceed to the penalty box to listen to a reprimand for the driving behavior. The amount of time spent in the penalty box will vary from one (1) to four (4) minutes depending upon the severity of the offense.

If it is impossible to impose a penalty by a stop under a black flag, e.g. not enough laps left, the event officials may add an appropriate time penalty to the team's elapsed time.

D8.18.10 Vehicle Control Issues

The Chief Marshall/Director of Operations may disqualify a vehicle if, for any reason including driver inexperience and mechanical problems, it is too slow or being driven in a manner that, in the sole opinion of the event officials demonstrates an inability to properly control the car. Disqualification for a vehicle control issue is scored as DNF.

D8.19 Endurance Scoring

D8.19.1 The score for the Endurance Event is the sum of the Endurance Time Score and the Endurance Finish Score.

D8.19.2 The Endurance Time Score is based on the sum of the scored Endurance times of both drivers in the event, compared to the fastest team.

D8.20 Endurance Scoring Formula

D8.20.1 Score for the Endurance Event is determined by:

If **T_{your}** is < or = to **T_{max}**:

$$\text{ENDURANCE SCORE} = 250 \times \frac{(\text{T}_{\text{max}} / \text{T}_{\text{your}}) - 1}{(\text{T}_{\text{max}} / \text{T}_{\text{min}}) - 1} + 25$$

If **T_{your}** > **T_{max}**: ENDURANCE SCORE = 25

T_{min} will be the lowest scored Endurance time of the fastest team of the event.

T_{your} will be the combined scored Endurance times of both of your team's drivers in the heat.

T_{max} will be 1.45 times **T_{min}**.

If Endurance is DNF: ENDURANCE SCORE = **LapsComp**

LapsComp is the number of full laps completed by the team.

D8.20.2 If, in the opinion of the officials, course conditions change significantly during the running of the event then they may, at their sole discretion, set **T_{max}** to a higher value.

D8.21 Efficiency

The Efficiency is based on a metric of the amount of fuel consumed or energy used and the lap time on the endurance course, averaged over the length of the event.

Teams are advised that the Efficiency score is based only on the distance cars run on the course during the Endurance event. Although the starting line, exit line and the driver change zone increase the actual distance a car must drive during the event, those distances are not factored into the fuel calculations. Additionally, fuel consumption adjustments will not be made for engine running in the entry/exit lines, during driver change, in the penalty box or for any on-course incidents.

The organizer may use either the corrected Endurance laptimes or the scored Endurance laptimes for the Efficiency event.

NOTE: Teams are reminded to refer to Rule IC2.7 which covers fuel tank filling requirements.

D8.21.1 Efficiency Scoring for EV

The organizer may decide to not measure efficiency for electric vehicles that are run in their own class. If efficiency will not be scored; then:

- The decision will be communicated prior to the start of the event
- Rule EV2.2 Power and Voltage Limitation remains in effect and does not change
- Other rules affecting the Endurance event and technical inspection will remain unchanged
- Each EV car that is eligible for Efficiency points per D8.22 will be awarded 100 points for Efficiency

D8.22 Efficiency Scoring Formula

D8.22.1 CO₂ conversion factor

The mass of CO₂ released to the atmosphere will be assessed by using the conversion factors below from quantity of fuel used to CO₂ released. The factors are intended to represent the average supply of the appropriate commodity and the organizers will not take account of where the actual fuel used came from.

Unleaded petrol / gasoline	– 2.31 kg of CO ₂ per litre
Electric	– 0.65 kg of CO ₂ per kWh
E85	– 1.65 kg of CO ₂ per litre

NOTE: The Electric energy value includes the anticipated charging losses if the pack is charged over 2 hours.

D8.22.2 EV credit for regeneration.

Full credit will be given for energy recovered through regenerative braking.

D8.22.3 Efficiency will be scored using the following formulas:

$$\text{EFFICIENCY SCORE} = 100 \times \frac{(\text{Efficiency Factor min} / \text{Efficiency Factor your})^{-1}}{(\text{Efficiency Factor min} / \text{Efficiency Factor max})^{-1}}$$

And

$$\text{EFFICIENCY FACTOR} = \frac{T_{\text{min}} / \text{LapTotal}_{T_{\text{min}}}}{T_{\text{yours}} / \text{Lap yours}} \times \frac{\text{CO}_2 \text{ min} / \text{LapTotal}_{\text{CO}_2 \text{ min}}}{\text{CO}_2 \text{ your} / \text{Lap yours}}$$

Where:

CO₂min is the smallest mass of CO₂ used by any competitor, whose Endurance time T_{your} < 1.45 x the average laptime of the fastest team that completes the Endurance event.

CO₂your is the mass of CO₂ used by the team being scored.

T_{min} will be the lowest Endurance time of the fastest team of the event, whose fuel volume does not exceed 26 liter/100km or energy equivalent of 60.06 kgCO₂/100 km.

T_{your} will be the combined Endurance times of the drivers in your heat.

Lap_{your}s will be the number of laps driven by the team being scored.

Lap_{totalmin} and **Lap_{totalCO₂min}** will be the number of laps completed by the teams which set T_{min} and CO₂min, respectively

EfficiencyFactor_{min} will be calculated using CO₂_{YOUR} equivalent to 60.06 kg CO₂/100km and T_{YOURS} set to 1.45 times the average laptime of the fastest team that completes the Endurance event.

- D8.22.4 Vehicles whose average Endurance laptime exceeds 1.45 times the average Endurance laptime of the fastest team that completes the Endurance event, will receive zero (0) points for efficiency.
- D8.22.5 Vehicles whose corrected average fuel consumption per lap exceeds 26 liter/100 km or energy equivalent of 60.06 kgCO₂/100 km, will receive zero (0) points for Efficiency.
- D8.22.6 The minimum Efficiency Factor is determined from the maximum allowable CO₂/100km and 1.45 times the corrected average Endurance laptime of the fastest team that completes the Endurance event.
- D8.22.7 Efficiency scores can range from zero points (0) to positive one hundred (100) points.
- D8.22.8 Vehicles which cross the start line following driver change are eligible for Efficiency points. Other vehicles will receive a score of zero points (0) for Efficiency.
- D8.23 Endurance and Efficiency Scoring with Two Heats**
If the Endurance and Efficiency is run with two (2) heats, the following procedure will apply:
- T_{min}** will be the lowest corrected time of the fastest team of the event in either heat.
 - CO₂min** will be the smallest mass of CO₂ used by any team in either heat; provided that team's Corrected Time from that heat does not exceed **T_{max}**.
NOTE: **T_{min}** and **CO₂min** do not have to be from the same heat.
 - The score for a team will be taken from the heat that gives the higher total Endurance & Efficiency Score for that team, i.e. **T_{your}** and **CO₂your** will be from the same heat.
- D8.24 Post Event Engine Check**
The organizer reserves the right to impound any vehicle immediately after the event to check engine displacement (method to be determined by the organizer) and restrictor size and for EVs to check the data to ensure that the maximum power limit was not exceeded
- D8.25 Endurance Event – Driving**
- D8.25.1 During Endurance when multiple cars are running on the course it is paramount that the drivers strictly follow all of the rules and driving requirements.
- D8.25.2 Aggressive driving, failing to obey signals, not yielding for passing, etc. will result in a black flag and a discussion in the penalty box with course officials. The amount of time spent in the penalty box is at the discretion of the officials and is included in the run time. Penalty box time serves as a reprimand as well as informing the driver of what he/she did wrong. Drivers should be aware that contact between open wheel vehicles is especially dangerous because tires touching can throw one car into the air.

Endurance is a timed event in which drivers compete only against the clock not against other cars. Aggressive driving is unnecessary.

D8.26 Endurance Event – Passing

D8.26.1 Passing during Endurance may only be done in the designated passing zones and under the control of the track officials.

D8.26.2 Passing zones have two parallel lanes – a slow lane for the cars that are being passed and a fast lane for the cars that are making a pass. On approaching a passing zone, a slower leading car will be blue flagged and must shift into the slow lane and decelerate. The following faster car will continue in the fast lane and make the pass. The car that had been passed may reenter traffic only under the control of the passing zone exit flagman.

D8.26.3 Passing, i.e. slow, lanes may be either to the left or right of the fast lane depending on the design of the specific course.

D8.26.4 These passing rules do not apply to cars that are passing disabled cars on the course or cars that have spun out and are not moving. When passing a disabled or off-track car it is critical to slow down, drive cautiously and be aware of all the vehicles and track workers in the area.

D8.26.5 Under normal driving conditions when not being passed all cars use the fast lane.

D8.27 Endurance Event – Driver’s Course Walk

The endurance course will be available for walk by drivers prior to the event. All endurance drivers are required to walk the course before the event starts.

ARTICLE 9: FLAGS

D9.1 Flag Effect

Flag signals are commands that must be obeyed immediately and without question.

D9.2 Flag Types

There are two kinds of flags for the competition: Command flags and Informational flags.

D9.2.1 Command flags are just that, flags that send a message to the competitor that the competitor must obey without question.

D9.2.2 Informational flags, on the other hand, require no action from the driver, but should be used as added information to help him or her to maximize performance.

D9.3 Command Flags

The following is a brief description of the flags used at the competitions in North America and what each flag means.

NOTE: Not all of these flags are used at all competitions and some alternate designs are occasionally displayed. Any variations from this list will be explained at the driver’s meetings.

D9.3.1 **BLACK FLAG** - Pull into the penalty box for discussion with the Chief Marshall/Director of Operations or other official concerning an incident. A time penalty may be assessed for such incident.

- D9.3.2 **BLACK FLAG WITH ORANGE DOT** - Pull into the penalty box for a mechanical inspection of your car, something has been observed that needs closer inspection.
- D9.3.3 **BLUE FLAG** - Pull into the designated passing zone to be passed by a faster competitor. Obey the corner workers hand signals at the end of the passing zone to merge into competition.
- D9.3.4 **CHECKER FLAG** - Your session has been completed. Exit the course at the first opportunity.
- D9.3.5 **GREEN FLAG** - Your session has started, enter the course under direction of the starter. (If you stall the vehicle, please restart and await another green flag as the opening in traffic may have closed.)
- D9.3.6 **RED FLAG** - Come to an immediate safe controlled stop on the course. Pull to the side of the course as much as possible to keep the course open. Follow corner worker directions.
- D9.3.7 **YELLOW FLAG (Stationary)** - Danger, **SLOW DOWN**, be prepared to take evasive action, something has happened beyond the flag station. **NO PASSING** unless directed by the corner workers.
- D9.3.8 **YELLOW FLAG (Waved)** - Great Danger, **SLOW DOWN**, evasive action is most likely required, **BE PREPARED TO STOP**, something has happened beyond the flag station, **NO PASSING** unless directed by the corner workers.
- D9.4 **Informational Flags**
- D9.4.1 **RED AND YELLOW STRIPED FLAG** - Something is on the racing surface that should not be there. Be prepared for evasive maneuvers to avoid the situation. (Corner workers may be able to point out what and where it is located, but do not expect it.)
- D9.4.2 **WHITE FLAG** - There is a slow moving vehicle on the course that is much slower than you are. Be prepared to approach it at a cautious rate.

ARTICLE 10: RULES OF CONDUCT

- D10.1 **Competition Objective – A Reminder**

The Formula SAE® event is a design engineering competition that requires performance demonstration of vehicles and is NOT a race. Engineering ethics will apply. It is recognized that hundreds of hours of labor have gone into fielding an entry into Formula SAE. It is also recognized that this event is an “engineering educational experience” but that it often times becomes confused with a high stakes race. In the heat of competition, emotions peak and disputes arise. Our officials are trained volunteers and maximum human effort will be made to settle problems in an equitable, professional manner.
- D10.2 **Unsportsmanlike Conduct**

In the event of unsportsmanlike conduct, the team will receive a warning from an official. A second violation will result in expulsion of the team from the competition.
- D10.3 **Official Instructions**

Failure of a team member to follow an instruction or command directed specifically to that team or team member will result in a twenty-five (25) point penalty.

NOTE: This penalty may be individually applied to all members of a team.

- D10.4 **Arguments with Officials**

Argument with, or disobedience to, any official may result in the team being eliminated from the competition. All members of the team may be immediately escorted from the grounds.

D10.5 Alcohol and Illegal Material

D10.5.1 Alcohol, illegal drugs, weapons or other illegal material are prohibited on the event site during the competition. This rule will be in effect during the entire competition.

D10.5.2 Any violation of this rule by a team member will cause the expulsion of the entire team. This applies to both team members and faculty advisors.

D10.5.3 Any use of drugs, or the use of alcohol by an underage individual, will be reported to the local authorities.

D10.6 Parties

It is expected that any disruptive parties, either on or off-site, will be prevented by the Faculty Advisor.

D10.7 Trash Clean-up

D10.7.1 Cleanup of trash and debris is the responsibility of the teams. The team's work area should be kept uncluttered. At the end of the day, each team must clean all debris from their area and help with maintaining a clean paddock.

D10.7.2 Teams are required to remove all of their material and trash when leaving the site at the end of the competition. Teams that abandon furniture, or that leave a paddock that requires special cleaning, will be billed for removal and/or cleanup costs.

ARTICLE 11: GENERAL RULES

D11.1 Dynamometer Usage

If a dynamometer is available, it may be used by any competing team. Vehicles to be dynamometer tested must have passed all parts of technical inspection.

Fuel, ignition and drivetrain tuning will be permitted while testing on the dynamometer.

D11.2 Problem Resolution

Any problems that arise during the competition will be resolved through the Operations Center and the decision will be final.

D11.3 Forfeit for Non-Appearance

D11.3.1 It is the responsibility of each team to be in the right place at the right time.

D11.3.2 If a team is not present and ready to compete at the scheduled time they forfeit their attempt at that event.

D11.3.3 There are no make-ups for missed appearances.

D11.4 Drivers Meetings – Attendance Required

All drivers for an event are required to attend the pre-event drivers meeting(s). The driver for an event will be disqualified if he/she does not attend the driver meeting or course walk for the event.

D11.5 Personal Vehicles

Personal cars and trailers must be parked in designated areas only. Only FSAE competition vehicles will be allowed in the track areas.

D11.6 Motorcycles, Bicycles, Rollerblades, etc.—Prohibited

The use of motorcycles, quads, bicycles, scooters, skateboards, rollerblades or similar person-carrying devices by team members and spectators in any part of the competition area, including the paddocks, is prohibited.

D11.7 Self-propelled Pit Carts, Tool Boxes, etc. - Prohibited

The use of self-propelled pit carts, tool boxes, tire carriers or similar motorized devices in any part of the competition site, including the paddocks, is prohibited.

D11.8 Starting

D11.8.1 Push starts are prohibited.

D11.8.2 The use of auxiliary batteries is prohibited once a car has moved to the starting line of any event.

D11.9 Footwear

Everyone in a “dynamic” area (an area where cars can be moving under their own power) must wear closed-toed shoes.

ARTICLE 12: PIT RULES

D12.1 Vehicle Movement

D12.1.1 Vehicles may not move under their own power anywhere but on the practice or competition tracks, or as otherwise directed by the organizers.

D12.1.2 Electric vehicles must be de-activated when being moved around the paddock.

D12.1.3 Off track vehicles must be pushed at a normal walking pace by means of a “Push Bar”, (See D12.2) and with a driver in the cockpit and with another team member walking beside the car.

The team has the option to move the car either with (a) all four (4) wheels on the ground or with (b) the rear wheels supported on dollies, by push bar mounted wheels, or other means as long as the person in the cockpit has full control of vehicle movement and can steer and brake normally. The external wheels supporting the rear of the car must be non-pivoting so the vehicle travels only where the front wheels are steered. The driver must always be able to steer and brake the car normally.

When the pushbar is attached to the car the engine must remain off.

D12.1.4 Cars with wings are required to have two team members walking on either side of the vehicle whenever the vehicle is being pushed.

D12.1.5 During performance events when the excitement is high, it is particularly important that the car be moved at a slow pace in the pits.

D12.1.6 The walking rule will be enforced and a point penalty of twenty-five (25) points will be assessed for each violation.

D12.2 Push Bar

- D12.2.1 Each car must have a removable device that attaches to the rear of the car that allows two (2) people, standing erect behind the vehicle, to push the car around the event site.
- D12.2.2 This device must also be capable of decelerating, i.e. slowing and stopping the forward motion of the vehicle and pulling it rearwards. It must be presented with the car at Technical Inspection.
- D12.2.3 A fire extinguisher has to be mounted to the push bar in a way that it is quickly accessible.
- D12.2.4 Electric Vehicles only: Two pairs of high-voltage insulating gloves and a multimeter have to be attached to the push bar. The HV gloves must be protected by a case or similar means from mechanical damage, humidity and sunlight. The case must also be able to be opened without using tools.

D12.3 Smoking – Prohibited

Smoking is prohibited in all competition areas.

D12.4 Fueling and Refueling

Officials must conduct all fueling and refueling.

D12.5 Engine and Vehicle Running Requirements

Engines may be run in the paddock provided the car has passed Parts 1 and 2 of Technical Inspection (S2.7) and the following conditions are satisfied:

- a. The car is on sturdy and adequate stand, and
- b. The drive wheels are at least 10.2 cm (4 in) off the ground, or the driver wheels have been removed.

ARTICLE 13: DRIVING RULES

D13.1 Driving Under Power

- D13.1.1 Cars may only be driven under power (a) when running in an event, (b) on the practice track and (c) during brake test or (d) during any powered vehicle movement specified and authorized by the organizers.
- D13.1.2 For all other movements cars must be pushed at a normal walking pace using a push bar (D12.2).
- D13.1.3 Driving a vehicle outside of scheduled events or scheduled practice will result in a two hundred (200) point penalty for the first violation and disqualification for a second violation.
- D13.2 **Driving Off-site - Prohibited**
Driving off-site is absolutely prohibited. Teams found to have driven their vehicle at an off-site location during the period of the competition will be excluded from the competition.
- D13.3 **Practice Track**
 - D13.3.1 A practice track for testing and tuning cars may be available at the discretion of the organizers. The practice area will be controlled and may only be used during the scheduled practice times.
 - D13.3.2 Practice or testing at any location other than the practice track is absolutely forbidden.
 - D13.3.3 Cars using the practice track must have all parts of the technical inspection sticker.

D13.4 Situational Awareness

Drivers must maintain a high state of situational awareness at all times and be ready to respond to the track conditions and incidents. Flag signals and hand signals from course marshals and officials must be immediately obeyed.

ARTICLE 14: DEFINITIONS

D14.1 DOO - A cone is “Down or Out” - If the cone has been knocked over or the entire base of the cone lies outside the box marked around the cone in its undisturbed position.

D14.2 DNF - Did Not Finish

D14.3 Gate - The path between two cones through which the car must pass. Two cones, one on each side of the course define a gate. Two sequential cones in a slalom define a gate.

D14.3.1 Entry Gate -The path marked by cones which establishes the required path the vehicle must take to enter the course.

D14.3.2 Exit Gate - The path marked by cones which establishes the required path the vehicle must take to exit the course.

D14.4 Staging Area - An area prior to the entry to an event for the purpose of gathering those cars that are about to start.

D14.5 OC - A car is “Off Course” if it does not pass through a gate in the required direction. Please reference the sections on Autocross and Endurance for further definitions of OC as applied to those events.